



Master Gardener's Manual



E-1034

**Oklahoma Cooperative Extension Service
Division of Agricultural Sciences
and Natural Resources**

Oklahoma State University



EXTENSION

Chapter 1: Who Are the Master Gardeners?..... 1

David Hillock

The Oklahoma Cooperative Extension Service ...	1
Creation of the Master Gardener Program	2
Responsibilities as a Master Gardener	5
Master Gardener Community Service	8
Communication	6
Using the Telephone	6
Writing Tips	7
Public Presentations	8
Master Gardener as Manager	10
Work Evaluation	10
The Master Gardener Paycheck	10
Liability	11
IRS Deductions for Master Gardeners	11

Chapter 2: Plant Science..... 12

David Hillock

Introduction	12
Plant Science.....	12
Classification of Plants	13
Plant Kingdom	12
Binomial Nomenclature	13
Plant Nomenclature	15
Botany: Plant Parts and Functions	15
Stems.....	15
Leaves	19
Buds	23
Roots	24
Flowers	25
Fruit.....	28
Seed	28
Physiology: Plant Growth and Development.....	28
Photosynthesis	28
Respiration	30
Transpiration	30
Environmental Factors that Affect Plant Growth	31
Light.....	31
Temperature.....	32
Water	33
Nutrition	35
Nutrient Outline.....	36
Plant Propagation	38
Sexual Propagation	39
See	39
Germination	30
Methods of Breaking Dormancy.....	40
Starting seeds	41

Transplanting and handling.....	44
Propagation of ferns by spores	45
Asexual Propagation	46
Cuttings	46
Layering.....	46
Separation	49
Division	49
Grafting.....	49
Budding	51
Plant Tissue Culture.....	51

Chapter 3: Soils and Fertilizer 54

Hailin Zhang

Soil Properties	54
Soil compositions	54
Soil depth	55
Soil texture	55
Soil structure	56
Internal drainage	56
Soil pH.....	56
Soluble salt	56
Organic matter	57
Essential Plant Nutrients	75
Macronutrients.....	57
Secondary nutrients	58
Micronutrients	59
Soil Testing and Fertilizer Application	59
Collecting a representative soil sample	59
Soil pH and BI (buffer index)	61
Plant available N, P and K in the soil.....	61
General guidelines of fertilization	61
Organic fertilizers	61

Chapter 4: Vegetable Gardening 64

Lynn Brandenberger, Jim Shrefler and David Hillock

Assessing the Garden Site.....	64
Soil Fertility: Basis for Gardening	65
Comparing Organic and Commercial Fertilizers	67
Composting	69
Guidelines	70
Tips.....	70
Soil Fertility Summary	71
Crops and Garden Layout.....	72
Alternatives to Traditional Gardening	73
Intensive Gardening Methods	74
Components of intensive gardens.....	74
Container Gardening.....	78

Gardening Tips.....	80	Stone Fruits.....	159
Things to avoid	81	Peaches and Nectarines	163
Additional tips.....	81	Plums.....	164
Soil Tillage	81	Apricots	165
Selecting Gardening Equipment	82	Cherries	165
Seed for the Garden.....	83	Other Crops.....	165
Transplants for the Garden.....	87	Elderberry.....	165
Summer Care	90	Jujubes	166
Watering	92	Kiwifruit.....	167
Weed Control.....	93	Persimmons.....	168
Mulching Garden Soils	93	Pomegranates	169
Mulching materials	94		
Fall Gardening.....	95	Chapter 6: Ornamentals	170
Fall garden summary.....	96	<i>David Hillock, Jason Vogel and Kyle Jarman</i>	
Extending the Growing Season.....	97	<i>Part 1: Landscape Design.....</i>	<i>172</i>
Season extending summary.....	101	Analysis of Site and Family Needs	172
Diagnosis of Abiotic (Non-Disease)		Factors Influencing Landscape Design	173
Vegetable Problems	102	Definition of Areas and Design	
Nutrient deficiency disorders	102	Considerations	174
Physical Disorders.....	103	Elements and Principles of Design	176
Disease and Nematode Control	108	Drawing a Landscape Design.....	178
Plant disease management tools	108	Selection of Plant Materials	180
Controlling nematodes	109	Gardening Practices for	
Fungicides.....	109	Sustainable Landscaping.....	182
Crop rotation.....	110	Sustainable Landscaping.....	182
Sanitation.....	110	Planning and Design	183
Insect Control	111	Xeriscaping	183
Organic Gardening Basics.....	112	Permaculture	183
Soil—the basics of organic gardening.....	113	Water Conservation	184
Herbs.....	117	Zone Appropriate Plant Selection.....	184
Production Hints for Popular Home		Smart Irrigation	185
Garden Vegetables	119	Runoff Management and Re-use.....	185
Harvest Hints	124	Soil Conservation.....	187
		Soil Improvement.....	187
		Use of Mulch	188
		Energy Conservation	188
		Green Roofs.....	188
		Strategic Shade and Windbreaks.....	189
		Reducing Pesticides and Fertilizers.....	189
		Reducing Pesticide Use	190
		Reducing Fertilizer Use	
		through Composting.....	190
		Appropriate Time and Amount of Fertilizing	
		Integrated Pest Management.....	190
		<i>Part 2: Herbaceous Plants.....</i>	<i>191</i>
		Planning the Flower Border	191
		Annuals.....	194
		Biennials	197
		Perennials.....	198
		Bulbs	201
Chapter 5: Fruits and Nuts			
In the Home Garden	128		
<i>Becky Carroll and David Hillock</i>			
Planning the Home Fruit Planting.....	129		
Site of planting.....	130		
Site selection	130		
Apples	132		
Berries	137		
Blackberries	137		
Blueberries	141		
Raspberries	144		
Strawberries	144		
Bunch Grapes	145		
Muscadine Grapes.....	148		
Pears	151		
Pecans.....	154		

Part 3: Woody Landscape Plants	227
Plant Selection.....	227
Planting Trees and Shrubs	231
Pruning and supporting.....	232
Watering	233
Mulching.....	234
Wrapping.....	234
Fertilizing	234
Transporting and Protecting Ornamentals	234
Ten Tips for Planting and Caring for New Trees.....	
Care and Maintenance	235
Fertilizing trees and shrubs	235
Mulching.....	236
Watering the landscape	236
Irrigation systems	238
Pruning landscape plants	239
Pruning techniques	240
Cultural and Environmental Problems	245
Leaf Scorch	245
Drought.....	245
Winter Burn on Evergreens	246
Injury by Freeze or Frost.....	246
Southwest injury	246
Winter freeze injury.....	247
Hail Damage.....	247
Ice Damage.....	247
Lightning Damage.....	248
Damage by misapplied pesticides	248
Grade Changes and Construction/ Oxygen Deficiency	250
Girdling Roots.....	252
Mowers and flexible-line trimmers.....	252
Sapsucker Damage.....	253
Selecting Plants for the Landscape	252
 Part 4. Indoor Plants	 293
Selecting an Interior Plant	293
Environmental Factors	294
Substrate	297
Containers	297
Repotting	299
Training and Grooming.....	300
Care of Special Potted Plants.....	300
Plants Lists	303

Chapter 7: Turfgrass	317
<i>Dennis Martin</i>	
Introduction	317
Lawn Benefits	318
Successful lawn management	318
Primary and secondary practices used in lawn care	318
Turfgrass Selection.....	318
Sourcing turfgrass species and cultivars....	218
Turfgrass selection and site assessment/client assessment.....	318
Grass Types	319
Bermuda grass.....	319
Buffalograss.....	321
St. Augustinegrass	321
Zoysiagrass	321
Turfgrasses for Shaded or Irrigated Sites	322
Proper Turfgrass Establishment Practices	323
Fertilization	323
Irrigation to supplement natural rainfall.....	325
Mowing	327
Tatch	327
Aerification.....	328
Weed Control.....	328
Herbicides and terminology	328
Weed identification and lawn grass identification	329
Insect Control	31
Disease Control	331
 Chapter 8: Entomology Basics	 333
<i>Eric Rebek</i>	
Introduction	333
Arthropod Classification	334
Species.....	334
Malacostraca	335
Archnida	335
Chilopoda	335
Diplopoda.....	336
Insecta.....	336
Insect Development	336
Insect Morphology (Form & Structure).....	337
Mouthparts	337
Wings.....	338
Antennae	339
Insect Identification	339
Coleoptera.....	340
Diptera.....	341
Hemiptera.....	341
Hymenoptera.....	341

Lepidoptera	341
Orthoptera	341
Dermaptera	342
Neuroptera.....	342
Thysanoptera.....	342
Other insect orders.....	342
Damage to Plants from Insects and Mites	342
Chewing damage	342
Sucking damage	343
Plant galls	343
Oviposition damage	344
Vectors of Diseases.....	344
Beneficial Insects	344

Chapter 9: Plant Diseases..... 345

Jen Olson

Introduction	345
The History of Plant Diseases	345
What is a Plant Disease?.....	346
The Disease Triangle	346
Host plant	346
Pathogen	347
Environment.....	347
The Disease Triangle in Action.....	347
Manipulate the host	347
Manipulate the pathogen	348
Manipulate the environment	348
Types of Plant Pathogens	349
Fungi.....	349
Bacteria	349
Viruses and viroids	350
Plant parasitic nematodes.....	350
Parasitic higher plants.....	350
Describing a Plant Disease	351
Environmental or Pathogen Problem?	351
Environmental Stress Problems.....	353
Selection of plant material	353
Proper planting	353
Proper plant maintenance	353
Site disturbance	354
Climate	354
Fertility and soil pH.....	354
Chemical injury.....	354

Diagnosis of Plant Diseases.....	354
Define the problem.....	354
Diagnose the problem.....	358
Management of plant diseases	358
Conclusion.....	359

Chapter 10: Understanding Pesticides and Their Alternatives 360

Charles Luper and Tom Royer

Terminology	362
Pesticide Formulations	362
Surfactants, Additives or Adjuvants	363
The Pesticide Label.....	363
Application Equipment.....	365
Proper Applications.....	367
Calibrating Sprayers and Spray Patterns.....	368
Using Pesticides Safely.....	368
Pesticides and the Environment.....	368
Home Garden versus	
Commercial Pesticides.....	371
Pesticides and Organic Gardening.....	371
Pesticides and the Law	371
Pesticide Conversion Chart.....	372
Integrated Pest Management.....	372

Chapter 11: Wildlife..... 377

Dwayne Elmore

Introduction	377
White-tailed Deer.....	378
Easter Cottontail	380
Armadillo	381
Pocket Gopher	382
Mole.....	384
Woodpecker.....	385
Canada Geese	386
Tree Squirrels.....	387
Northern Raccoon.....	388
Striped Skunk	389

Chapter 1

WHO ARE THE MASTER GARDENERS?

Learning Objectives:

The purpose of this section is to explain why the Master Gardener Program was created, what Master Gardeners do and how they are tied to the government agency that created and administers the program—the Cooperative Extension Service. This section also explains many of the tasks Master Gardeners perform, and suggests ways to improve telephone, writing and public presentation skills.

Chapter 1: Who Are the Master Gardeners?.... 1

The Oklahoma Cooperative Extension Service ...	1
Creation of the Master Gardener Program.....	2
Responsibilities as a Master Gardener	5
Master Gardener Community Service	8
Communication	6
Using the Telephone.....	6
Writing Tips.....	7
Public Presentations.....	8
Master Gardener as Manager	10
Work Evaluation.....	10
The Master Gardener Paycheck	10
Liability	11
IRS Deductions for Master Gardeners	11

Congratulations on the decision to enroll in the Oklahoma Master Gardener Volunteer Program. This program is offered by the Oklahoma Cooperative Extension Service (OCES) at Oklahoma State University, which carries on a tradition of agricultural and family and consumer science education spanning over a century. With an office in every county, OCES is the most pervasive outreach arm of OSU. It takes research-based university knowledge into homes, businesses and communities of all Oklahoma citizens. We would like you to better understand what OCES does, how it helps fulfill OSU's land-grant mission, and what additional benefits are available. The Master Gardener Volunteer Program comes with a rich history and we would like to share it with you.

The Oklahoma Cooperative Extension Service

In 49 states (and four Canadian provinces) where the program exists, Master Gardeners (MG) are trained and supervised by the Cooperative Extension Service (CES). In fact, the CES created the MG Program. When you work as an MG, you are representing the CES in your state.

Genesis of CES

The CES grew out of the U.S. Congress' concern for the education of the average citizen. Prior to the Civil War, few college curriculums ad-

dressed the problems of citizens making their livelihood from agriculture. In 1862, congress passed the Morrill Act, which provided a university in every state that would educate citizens in agricultural and mechanical fields. These colleges are known today as “land-grant universities.”

Congress soon realized that to be effective, the educational function of land-grant universities must be supplemented with a research capability. Consequently, Congress passed the Hatch Act in 1887. This act enabled the establishment of facilities where colleges could conduct research into agricultural, mechanical and related problems faced by the rural citizens and the general public. You may have passed one of these research stations on a trip or even know of one near your home.

Finally, to spread the benefits of the land-grant universities into the most remote parts of each state, congress passed the Smith Lever Act of 1914. This act established the CES. As a result of the Smith Lever Act, there are Extension offices in every county. These offices serve to “extend” information, which has been developed on campuses and research stations of land-grant universities to the public. In fact, Extension educators are considered members of the university faculty, since their role is primarily educational.

Organization of CES

As an MG, the vast majority of your contacts with the CES will be through the local Extension office and educators. Local educators determine, within a set of state guidelines, how to teach and administer the MG Program in their Extension office. Each Extension office in Oklahoma conducts programs in Agriculture (including horticulture), Family and Consumer Sciences, 4-H and Youth Development and Rural Development. MG’s generally fall within the Agriculture educator’s sphere of responsibility, but many have used their horticultural skills to conduct programs in cooperation with other Extension programs. In some counties, we are fortunate to have a Horticulture educator who coordinates and manages the MG program.

Several tiers of administrators rise above the local Extension office. Oklahoma’s 77 Extension units are divided among four districts. District staff includes a district director, program leaders and area specialists, who provide administrative and/or program development assistance to the local unit offices. These four districts communicate to

state-level administrators at the land-grant university. The state Extension administrators provide a liaison between the state Extension service, OSU Division of Agricultural Sciences and Natural Resources and the U.S. Department of Agriculture, which oversees and evaluates state Extension programs.

In addition to administrative and program development assistance, the land-grant universities provide technical support to the local Extension office. This is essential, since no Extension educator can know the answers to every question posed by the public. In addition, land-grant universities employ Extension specialists in specific areas such as horticulture, soils, turf, diseases, insect problems, etc. Local Extension offices and their MG’s often contact these specialists for answers to difficult questions.

Volunteers in Extension

Volunteer groups are one of the most important and unique aspects of the CES. This is in keeping with the Extension philosophy that active citizen participation in planning and implementation ensures program success. As an MG, you will join this family of volunteers.

Each Extension office has an Advisory Board made up of local citizens and civic leaders, who provide feedback and direction to programming. Many Extension educators ask their MG’s to serve on this board. Other Extension educators may ask MG’s to act as program coordinators, who perform much of the administration of local MG activities.

Creation of the Master Gardener Program

In 1972, the state of Washington created the MG Program to meet an enormous increase in requests from home gardeners for horticultural information. This increase was in direct relation to the urban and transient nature of modern American life. Sixty years ago, an Extension educator dealt with the questions of a few hundred farm families. However, in many regions, land that once constituted a single family farm now encompasses several hundred homes. This increased the number of families an Extension office serves. In addition, many of these families are recent arrivals, and are unfamiliar with what grows in the microenvironment

of their new urban or suburban home. They will often call their local Extension office for advice on what to plant and how to care for it. The MG Program is now found in 49 states and four Canadian provinces.

MG's have become a vital part of Extension's ability to provide consumers with up-to-date, reliable knowledge, so they can enjoy and protect the value of horticulture around their homes. Master gardening has also become a fun and useful volunteer activity, which has given its participants a sense of community spirit, fellowship, accomplishment and intellectual stimulation.

Responsibilities of a Master Gardener

When you enter the MG Program, you are entering into a contract. In essence, you agree that, in return for the training you receive, you will volunteer hours back to Extension. Upon completion of your training, you have one year to complete the agreed-upon volunteer service commitment. The time requirement varies from one Extension unit to another. In Oklahoma, the minimum number is 40 hours per year. The "Oklahoma Master Gardener" title is to be used only and exclusively when doing unpaid volunteer educational work in the OCES MG Program; in which trained and certified MG's assist the horticulture program.

Oklahoma MG's are not to advertise their names or place of business, nor to be listed on the advertisements of business places as an MG. This is an OCES public service program. Appearing as a commercial activity, having association with commercial products or giving implied Extension Service endorsements of any product or place of business is improper under the MG contract.

The training and experience gained by participation in the MG Program are valuable and may rightfully be listed and featured as qualifications when seeking employment. Once employed or self-employed and serving as a paid employee, MG's should not display credentials or give the appearance of an acting MG unless designated by the county MG coordinator.

In making recommendations that include the use of chemicals and/or biological agents, Oklahoma MG's must follow published OCES recommendations. These recommendations may be found

in the Extension Agent's Handbook, fact sheets, current reports and other materials approved by OCES. Use of other pesticide recommendations is not approved. Home remedies are not to be given as an MG. Chemical recommendations may include other trade names not listed in OCES-sanctioned material if approved by the county MG coordinator or state specialist.

NOTE OF CAUTION: Individuals who are not acting on behalf of OCES are strongly urged to minimize the appearance of being on duty before making any horticultural recommendations. Speaking "off the record" is your right; however, make it clear you are speaking for YOURSELF and not the OCES.

Experienced MG's are likely to receive invitations to give group presentations. Gratuitous payments for speaking are considered separate from the questions-and-answers performed at MG plant clinics and in-office duties. However, do not seek payment for speaking engagements.

Standards for MG conduct were established to create a safe and pleasant learning environment. All MG volunteers must recognize the necessity for representing OCES in a manner consistent with exemplary citizenship and leadership.

MG's are expected to participate in all components of the volunteer program to fulfill their obligation, be responsive to the county educator in charge, and be respectful of safety in general and of others.

Recertification

After completion of payback time, you may choose to continue with the MG Program. Many Oklahomans have worked as MG's for years and contributed substantial amounts of time to Extension. In some cases, thousands of hours! Master Gardeners who wish to continue after the first year must recertify. The requirements for recertification are

- (1) completion of the initial 40-hour (minimum) payback in volunteer activities,
- (2) accumulation of 20 hours of further educational activities, and
- (3) willingness to volunteer an additional 20 hours of community service work the following year.

Determining the value of educational activities is the responsibility of the county MG coordinator. If you choose not to continue in the MG program,

you may not represent yourself as an MG in the future.

Continuing education hours may be accrued by attending seminars in landscaping, vegetable gardening, pruning demonstrations, lawn and garden shows, field days or attendance at the Oklahoma Horticulture Society or other professional or industry meetings. Activities are not limited to Extension-sponsored programs. Garden club programs, plant society programs, state park programs and nursery-sponsored seminars also count. Field trips to nurseries, horticultural operations or visiting public gardens such as The Botanic Garden at OSU or other gardens can also be used to accumulate recertification hours. Any additional educational opportunities related to horticulture are the discretion of the county coordinator.

The following Extension-sponsored programs should be given emphasis: State Master Gardener Conferences, Horticulture Industries Show (HIS), monthly MG meetings with an educational component and other workshops offered by the Department of Horticulture & Landscape Architecture. Several national and regional conferences are also held to provide opportunities for MG's to learn. These include the International Master Gardener conference, held on odd-numbered years, and the Southern Region Master Gardener Conference, held on even-numbered years.

A copy of the program, or an outline of the learning activity, must be given to the county coordinator to assign an hour value. Hours are typically based on the hours included in instruction, excluding lunch, breaks or drive time.

Research time an MG used for giving a program on a horticultural topic also counts toward the 20-hour total. For example, if an MG is teaching lawn care for a garden club, the time spent researching and developing the program counts, provided it is within reasonable limits. Usually two to three hours is assigned for this activity, not the total preparation time. Gardening-related literature reviews written for newsletters, or given as a program for an MG meeting is valued at one hour.

Total recertification cannot be earned by retaking the Master Gardener training course. Recertification of MG's means training or education above the basic information offered initially. Only two hours per day of Basic Master Gardener Training Course attendance can count toward recertifica-

tion. Space may be a limiting factor on the number of recertifying Master Gardeners allowed to attend.

Recertification is not meant to be difficult – it is simply a means of keeping current on horticultural practices. MG's have a calendar year to earn 20 hours continuing education hours. MG's who find this program interesting and rewarding usually end the year with many more than the required 20 hours.

Recertification hours must be accrued each year and cannot be carried over from previous years.

Guidelines for receiving continuing education hours

- **Attending MG meetings with educational programs.** Each county is encouraged to hold monthly business meetings, which provide additional educational information by inviting guest speakers or by a fellow MG sharing information learned.
- **Attending conferences.**
- **Visiting public gardens** with (a) a guided tour, (b) informational signs posted in the garden or (c) informational brochures or tapes ensuring the visitor learns about the garden.
- **Reading gardening books or watching gardening videos.** To make these count, the MG should fill out a short book report form. This will prove that the MG actually read the book and will provide a guide for others wanting the same kind of information. MG's may also give programs on the book or tapes. Programs should be at least 45 minutes long. (Watching TV shows or reading magazine articles will not count.)

Some counties have allowed the watching of certain television programs such as *Oklahoma Gardening*. The number of hours watching TV is limited to only a few hours.

These are only suggestions on ways an MG can obtain continuing education hours. Your county educator may or may not allow some of these suggestions. The number of hours an MG can claim, such as visiting gardens, reading books, watching tapes and *Oklahoma Gardening* should be limited. Whenever possible, the MG is encouraged to first attend educational programs designed to enhance their horticultural knowledge and strengthen camaraderie between fellow MG's.

Your work is appreciated by OCES and local area gardeners who have or will receive counsel

Recording Volunteer Activities. An MG on-line reporting system has been created to make it easier to record and keep track of volunteer activities and continuing education hours. This can be done on a daily basis or anywhere with computer access. Check with your county educator for information regarding website registration.

Time Sheets. Time sheets may also be used to keep track of volunteer hours. These may then be used to help enter information on the on-line reporting system. Do not be lax in reporting your time; you deserve recognition for your efforts!

Recording volunteer data is an important part of the MG Program. Not only does reporting data allow Extension to reward volunteers for their hard work, but also it is valuable for program evaluation. The reporting system provides a record of the many ways MG's serve the public. Local and state governments, which fund Extension, are very interested in how effectively tax revenues are used. Detailed records benefit both the MG Program and its clients.

Master Gardener Community Service

Since the MG program first started, the activities of MG's have broadened considerably. In the early years, MG's mostly answered telephone requests for gardening information. They also staffed plant clinics and information booths. These tasks are still vital to Extension. However, in recent years, creative MG's and Extension educators have utilized talents that citizens bring to the MG program in a variety of horticultural activities.

Examples of activities in which MG's have participated are listed below. Note: not all activities involve examining or discussing plants. All activities do help Extension provide horticultural information to the public. If you have an activity which utilizes your special talents, discuss them with the local educator. He or she might agree it would be a good way for you to contribute to the MG Program and Extension.

- Create and maintain demonstration gardens.
- Garden with the elderly and handicapped.
- Volunteer at county fairs and plant clinics.

- Home gardening visits.
- Conduct garden projects at halfway houses for those recently released from mental health institutions.
- Act as a liaison for the Extension office by answering gardening questions.
- Produce a monthly horticulture newsletter for homeowners.
- Conduct school gardening programs.
- Give group talks to those interested in horticulture.
- Present 4-H camp demonstrations.
- Coordinate regular and advanced MG programs.
- Instruct new MGs.
- Coordinate videotaping of MG program on cable TV or appear as a guest on televised gardening programs.
- Participate in on-site lawn clinics.
- Work in trial gardens at a research station.
- Conduct garden tours.
- Plan and implement public relations projects.
- Work on special event projects (Arbor Day, Field Day).
- Plan and complete community beautification projects.
- Public education about insect and disease problems.
- Compile plant lists.
- Photograph MG activities.
- Conduct 4-H vegetable shows.
- Manage a plant diagnostic lab.
- Work as program president, vice president, secretary or treasurer.
- Manage farmers' markets.
- Create and maintain a youth garden.
- Process or take soil samples.
- Maintain an office reference library.
- Design brochures.
- Solicit donations for program expenses.
- Conduct Junior MG program.
- Solicit seed donations.
- Design and maintain community and school landscapes.
- Conduct vegetable gardening projects with young offenders or low-income youth.
- Contribute to the preparation of the MG Handbook and fact sheets.
- Judge school science fairs.
- Produce slide presentations.

- Organize beginning MG or MG graduation picnics.
- Volunteer as 4-H leaders.
- Serve as experts to identify plant material.
- Assist at registration desks for various conferences.
- Serve on Extension Program Advisory Committee.
- Contribute to or help maintain web sites, blogs, Facebook pages, etc.

Communication

As an MG, you will work with all sorts of people. Clientele will come to you with questions and problems concerning horticulture. To fully understand the client's problem and suggest a solution, you must be able to communicate effectively. This can be a challenge, since the object of discussion is often not present. If the sample cannot be brought in, you must deduce the problem from a verbal description of the symptoms. In many cases, it is suggested to encourage the client to bring the pest, sample or plant in for diagnosis.

Effective communication is not just speaking clearly and listening closely. As you listen to a client's description of his ailing indoor plant, you are trying to understand a situation you have not experienced. It is very easy to leave out details when we describe something familiar. The client may not realize the color of the leaf edges or the proximity of heating ducts to the plant are important clues to the plant problem. You can improve communication by asking several questions.

By thinking of all the possible symptoms and conditions matching the description, you can pose questions to yield enough information and find a solution. It is a good idea to summarize your findings and present them to the client. Don't be afraid to say, "I am going to describe the condition of your plant as I understand it. Stop me if I have it wrong." After all, what we mean and what we say are not always the same. Humans have ways of interpreting meaning from voice changes, gestures, facial expressions and general body language, as well as words. The important point is to express our understanding so the client can compare it with his knowledge of the situation.

With today's technology, we have the option of receiving images of a plant or situation. In this case, the saying "a picture is worth a thousand

words" couldn't be more true. A good photo of a plant problem can tell us a great deal. Encourage clients to send photos whenever possible, especially when a sample cannot be brought in. Ask them to take clear, sharp pictures of the affected plant, the entire plant and the area it is growing. The more pictures a client can send, the better we can understand the story. Remember, if the picture is blurry or out of focus it will be ineffective in solving the problem.

A stumbling block to communication, other than incomplete information from the client, is the MG's horticultural expertise. This can be a problem in two ways. The MG can know an abundant amount about a topic and does not bother to listen to everything. Or, the problem may be identified and possible solutions discovered, but the MG cannot describe the necessary procedures in terms the client can understand. Germination, propagation and fertilization are all nice terms, but they are useless if they illicit blank stares. There is nothing wrong with basic terms such as grow, dig and water.

No one person knows everything. As an MG, you know a great deal about horticulture, but remember one of the most important things to know is how to find answers. In your work at plant clinics, or at the Extension office, you have access to excellent resource materials. If your client's problem is too complex to solve with your knowledge and resource material, take the person's name, address and phone number. Then you can take your time to answer the question thoroughly or see it is answered by Extension personnel.

Using the telephone

When working with clients by telephone, communication can be more difficult because there are no visual clues. Listen carefully and ask many questions. Familiarize yourself with the office procedure for telephone use. Your Extension educator or someone on staff should be able to provide information such as what to say when answering the phone and how to log calls.

Every time you make or receive a telephone call as an MG, you are representing the OCES. The impression you create can be long-lasting and may determine whether or not the person will continue to use the Extension Service.

When the telephone rings, answer promptly. Quick service helps build a reputation of efficiency. Identify yourself by first name and the MG title. This

helps get the conversation off to a good start and personalize the phone call. Be friendly and a good listener, so the caller will not have to repeat information. Be considerate and do not carry on two conversations at once. Callers should be made to feel like they have priority, and are not competing for your attention.

Sound as good as you are. Show that you are wide awake and ready to help the person on the line. Use simple, straightforward language. Avoid technical terms and slang whenever possible. Speak directly into the telephone and pronounce words clearly. Talk at a moderate rate and volume, but vary your tone of voice.

When you must put a caller on hold, it is courteous to ask, "Will you hold? Or shall I call you back?" It is better to get a name and number than to leave a customer on hold for long periods of time. Calling clients back allows the MG to do stress-free research. However, if the person chooses to stay on the line, use the hold button or lay the receiver down gently. Do not talk where the caller can hear your conversation. If it takes longer than you expected to gather material, return to the line every 30 seconds to assure you're working on the request. When you have the information, thank the caller for waiting. Transfer a call only when necessary and explain why you're connecting the caller with someone else. Be sure the client is willing to be transferred. If the customer does not want to be transferred, have someone call them back.

When answering the phone for someone else, be tactful. Comments such as "He hasn't come in yet" and "She's just stepped out for coffee" can give the wrong impression. It's better to say "Mr. Jones is away from his desk. May I ask him to call you?" When you take a message, be sure to write down the name, time, date, telephone number and the reason for calling. Don't hesitate to ask the individual to spell his name or repeat his number.

You will occasionally speak with a caller who is difficult to work with. Remain calm and don't take comments personally. As long as you're being friendly and trying to help, you are doing your job. Retain your sense of humor and give the caller your sincere attention. In difficult or uncomfortable situations, take messages for the Extension educator to handle.

Because people are relying on you for information, knowing how to utilize Extension horticulture publications is important. Printed material is a

time-saving device for county staff and specialists. Today's technology allows quick, easy and free access to most Extension publications on the website osufacts.okstate.edu. Sharing those links or sending email attachments is a quick and efficient method in distributing information to clientele.

Writing tips

MG's have no shortage of opportunities to utilize writing skills. Many MG's produce publications for local gardening issues, scripts for presentations or write newsletters and columns for local newspapers.

Organization and simplicity will help you achieve a well-written product. Start with a clearly defined purpose and outline. An easy way to understand the purpose of your writing is to create a title. A good title about the subject in few words conveys most information about the article. "All about Grapes" indicates a large amount of material is going to be covered: history, varieties, culture and uses of the fruit. If only writing about grape culture or pruning, feel free to say so. Do not mislead the audience. Once the title is written, you know how to limit the topic and what to cover. The roughest outline is better than none at all, and bare-bone structures can make it easy to see the logic behind the subject you create. It is easier to repair holes in the outline stage earlier rather than later. Prevent having to redo quality paragraphs or even deleting pages altogether. Writing is a lot like pruning, more easily done when there are no leaves on the tree.

After the title and outline are finished, writing can proceed. Address each topic on the outline, and soon the job will be complete. Remember a topic sentence for each paragraph. Explain each topic on the outline and support what you say with reliable information. If you get writers block, re-examine what you are trying to express. Maybe there is nothing more to say than the sentence already there. Perhaps it is irrelevant or misplaced in the outline. If all else fails, take a break. A change of scenery and time away from words can do wonders. When you come back to writing, the problem may be perfectly clear with an obvious solution.

Simplicity is essential to clear, concise writing. Even though vague phrases invade business letters, news writing, television and radio, there is no need to follow and promote the trend. For instance, "We would like for you to stop by our office" can be replaced with "Please come into our office." The

same message is conveyed with greater clarity using half the words. If you find yourself struggling over a choice of words, try saying the sentence out loud or to someone. Listen to yourself as you say it, because you are probably saying the words you need to use. Avoid slang, jargon and flowery or obscure vocabulary. You can't go wrong using the simplest English words and correct grammar. The goal of good writing is to communicate, not confuse.

An interesting sentence carries a strong verb and few adjectives. If you must shorten a piece of writing, you can sacrifice adjectives for space and simplicity. Articles (a, an, the) are often unnecessary. Some languages do not have articles at all; we can probably do without some of ours.

Perhaps the most common misunderstanding about writing is it is easy. Some people are more adept at writing than others, but those who write well will usually admit it takes work. Just as good gardeners must get their hands dirty, good writers spend hours rewriting, using dictionaries and grammar books. They are checking the actual meaning of "cultivate" or whether there is a hyphen in "damping-off." Find a good dictionary and use it.

Existing or new publications may need to be adapted for local conditions. If an Extension educator decides you can develop new materials, check office files for old publications or contact the appropriate specialist. Some materials may already be available and only need slight modification to be utilized. After educational material is complete, send a copy to appropriate specialists at the Horticulture and Landscape Architecture Department at OSU to be shared with other offices.

When producing new materials from old publications, do not infringe on a copyright. Most Extension materials are not copyrighted. However, if you want to use copyrighted material or any of its components (this includes artwork), written permission must be obtained from the publisher, and often from the author or artist as well. Do not download photos, text or graphics from the Internet!! Get permission first.

Public presentations

Because the role of the Extension Service provides information and educates the community, you will have plenty of opportunities to appear before the public in your capacity as an MG. Not only do MG's interact with the public at the Extension

office, but many become very knowledgeable about a specific subject. Because of this specialization, MG's are invited to give talks to clubs and groups. This is a wonderful way to help Extension, as educators are often in high demand for such talks. Educators and MG's are also called upon to provide workshops, demonstrations and tours.

Most public presentations have four components: title, introduction, body and summary. The title should be short, descriptive of the subject and pique the interest of the group. The introduction tells who you are and elaborates on the goal or content of the talk in a way that captivates the audience. This part of the presentation is key to the success or failure of a talk, as it sets the tone for the remainder of the program. The body of the presentation contains the substance and should satisfy the curiosity of the audience. Use research-supported information and cite references whenever possible (can be done at the end of the talk). The summary re-states the major points of the presentation in sequence. The summary should be short and clear. Be prepared to answer questions following a presentation. Repeat the questions for the audience if they are difficult to hear or understand, then provide and answer.

Public presentations take practice and preparation to be successful. Don't be fooled by a casual delivery; many people who appear relaxed and speak effortlessly in front of groups have spent many hours achieving this effect. To plan a presentation, consider:

- the audience
- the audiences knowledge level of the subject
- technical difficulty of the subject
- timeliness
- appropriateness
- purpose
- materials required
- length of presentation

After collecting materials, studying and reviewing notes, **rehearse** the presentation. Observe these points carefully during rehearsal:

- Are charts, graphs, images and posters easy to see and read? If you cannot read the text, remove it.
- Avoid including too much text on a single slide when using PowerPoint. Allow one slide for every minute of presentation length.
- Can the audience hear the speaker from anywhere in the room?

- Are the materials used in the demonstration arranged so they are accessible and easy to reach?
- Does the speaker make unnecessary apologies? Avoid saying “This is the first time I’ve done this” or “I’m not used to speaking before groups.” Do the best job you can. The audience doesn’t expect you to be perfect, and you are probably much better than you think you are.
- Avoid saying “um,” “okay” or long, uncomfortable pauses.
- Include personal stories or anecdotes as much as possible.
- Don’t stand completely still, move about the room in a friendly manner.
- Try to make eye contact with everyone in the group.
- If you are giving a demonstration with another person, are the delivery and action coordinated? Or does one member do the majority of the talking? Does the other’s participation seem necessary?

If you are preparing an exhibit for public presentation, here are some basic concepts to keep in mind when planning and setting it up:

- Choose one idea that can be explained in a simple, catchy statement. Use few printed words.
- Have a single center of interest to catch the eye.
- Develop a complete story using as few items as possible. Eliminate clutter in an exhibit.
- Create orderly, interesting and artistic designs.
- Attract attention with movement, color, light, sound or a clever title and attractive design. Do not use all of the above at once.
- Make sure charts, posters and visuals are attractive, neat and clean.
- Evaluate exhibits by asking if it attracts attention, arouses interest, conveys a message and is well-constructed.
- Select well-informed people to man exhibits. They should be able to meet the public easily and create a favorable impression.

Advertising public presentations is key. Too often, well-prepared programs fail to reach a large audience because of a lack of adequate advertising. Word of mouth is not sufficient. Public events

can be announced in newsletters, newspaper feature articles, regular columns, paid advertisements, radio and television public service announcements, on posters displayed in appropriate locations and through websites and social media. It can be helpful to find a local sponsor to assist in financing and advertising an event, such as a garden center, bank or chamber of commerce. Clearly define all arrangements with sponsors and agree upon responsibilities ahead of time. When advertising outdoor events with no indoor facilities, such as garden tours or community garden visits, include rain dates and inclement weather dates ahead of time.

Preregistration can serve as an indicator of expected attendance. Some educators report positive responses from workshops requiring a minimal pre-payment fee to cover material costs. Participants are more interested and motivated to attend after making a financial commitment.

Slides (digital images and PowerPoint presentations) are available for use in public presentations through county offices, the Horticulture and Landscape Architecture Department as well as other departments within the College of Agricultural Sciences and Natural Resources. Videos are also available. Ordering guidelines and selection information can be found at your county Extension office.

If no slide sets are available for use, and you have adequate time for the project, you may want to produce your own slide set. Begin with the same basic principles for good writing and speaking: clarify the subject and identify the audience.

Illustrations and photographs should relate directly to the script, so work on the text before adding photos. Decide what should be illustrated and prepare a list of objects to be photographed. Plan to shoot more pictures than you need and shoot retakes. Professional photographers often take hundreds of pictures before finding a masterpiece. Avoid busy, complicated slides.

When presenting a slide program avoid phrases such as “This is a slide of...” “Here we see...,” “Now we’re looking at...,” “Next we have...,” “This picture you’re watching...” Instead, talk about what is in the picture. Do not leave a scene on the screen for less than five seconds nor for long periods of time. For each topic change, a new subject should be immediately identifiable. Do not let the audience wonder why they are looking at a wheel-

barrow when a second ago you were discussing beans. Begin with the point you are trying to make, and then explain it. Do not ask the viewer to recall a prior slide. If you want to bring attention to the same slide two different times, include the slide twice, at the appropriate intervals.

Always review slides before the talk and familiarize yourself with equipment and software compatibility. Memorize the first five minutes of your talk. This eliminates the need to read an introduction, and helps with the forgetfulness that often occurs with stage fright. Depending on time, answer questions as they arise, but avoid straying too far off topic.

The Master Gardener as manager

MG volunteers make it possible for Extension educators to reach more people with horticulture programs. This expansion of program services makes the educator more efficient, but increases responsibility. Therefore, it is important MG's manage the program. While the Extension educator continues to advise the program, MG's can act as volunteer coordinators for activities performed by the group. In some units, there are several coordinators, each one responsible for a different program need.

After the MG program becomes established, volunteer coordinators can help strengthen the program by planning and goal setting. By meeting and working with the Extension educator, MG's can help determine the needs of the community. They can help decide the best route for disseminating horticultural information and establishing projects to meet those needs. It is important to set goals and determine how to gauge the program success. MG's need to keep records of their work; the volunteer coordinator can explain the importance of this to the other volunteers and see that accurate records are kept.

The MG program needs a volunteer coordinator from the beginning. If you possess management skills, or think you could become a good manager, express your interest to the Extension educator. Some signals you may be a good manager are: do you make suggestions on how to schedule the plant clinics, staff the tasks that need completed, match volunteers and outline the tasks to finish the job? As a volunteer coordinator during the first training session, you may be selected to help with the audio-visual equipment or guide the students

after a break. Coordinators begin with small jobs, then take on more complicated tasks as the program progresses. Veteran MG's are often involved in decision-making concerning new projects, advanced training and screening of new MG's.

Work Evaluation

The MG and the local Extension educator should plan to evaluate performance of volunteer tasks. In return, the MG program should evaluate the adequacy of support from the Extension office. The purpose of evaluation is to ensure satisfaction with volunteer work and determine whether the performed tasks are worthwhile for the MG, the community and the Extension Service.

As an MG volunteer, you can expect the following from the Extension Service employees for whom you work:

- Concise explanation of jobs and opportunities for volunteer service.
- Staff guidance and support in accomplishment of tasks.
- Recognition of outstanding accomplishments.
- Integration of MG volunteers as partners in the accomplishment of the Extension mission.
- Continuing MG training opportunities.
- Periodic evaluation of MG performance.

The Extension Service expects the following from you:

- Assistance in developing meaningful jobs and opportunities for MG's.
- Timely notice of needs and support from the Extension staff for required tasks.
- Reporting of tasks accomplished, number of hours involved and task evaluation at specified reporting time.
- Acting as a partner on the OCES team in a manner that reflects favorably upon both parties.
- Recruitment of individuals for future MG training.
- Periodic participation in conferences with Extension educators to evaluate tasks(s) performed and Extension's support of MG programs.

The Master Gardener Paycheck

Volunteers are not paid with money, but are worth more than the price of gold. We hope the gratitude

of your fellow workers in the Extension offices, the district and state staff help you feel your work is appreciated. Certainly, the citizens who seek you out with plant problems will indicate you are valuable and needed.

Liability

The OSU indemnification policy is extended to Master Gardener Volunteers performing services solely for and under the direction of OCES.

IRS Deductions for Master Gardeners¹

Do you itemize deductions, i.e. reduce your tax owed because you have a home mortgage, pay real estate taxes, have very large medical expenses or contribute to church or charities? If yes, the following will be of interest to you.

As MG's, you contribute time and energy to assist the county with homeowner horticulture problems. This is viewed by the IRS in the same way as working for any qualified charity. While time is never deductible, many of your expenses are deductible; they are as follows:

AUTOMOBILE TRAVEL EXPENSE – actual cost of gas and oil, or the government mileage rate of cents per mile. You may deduct trips to the Extension center or other locations where you perform services on behalf of the MG program. This includes monthly training sessions, but does NOT include the initial training program for MGs. Check with your personal tax advisor for specific up-to-date deductions and mileage fees.

ANNUAL UPDATE AT THE UNIVERSITY (State MG Conference) – auto travel expense as stated above, or your share if expenses were divided. In addition, the reasonable costs of lodging and meals may also be deducted. The seminar fee may also be deducted, but not the cost of additional books purchased.

To deduct these expenses, add them all together. Then include the total in the proper Schedule of your tax form on the line for listing cash gifts to charities. As with all income tax requirements, maintain your records for a minimum of three years.

As a final reminder, check with your local tax advisor for specific details or further questions.

¹ The above article is from the Florida Master Gardener News, February 1991, Vol. 4, No. 1. It was written by Bob Eickenberg, a tax associate from Hillsborough County, Florida.

Chapter 2

PLANT SCIENCE

Introduction

Learning Objectives:

After completing this section, Master Gardener trainees will be able to:

- Have a general understanding of horticulture and plant classification.
- Learn principal characteristics of green plants, their structure and common horticultural terminology.
- Know how environmental factors affect the growth and development of a plant.
- Understand the methods and reasons for plant propagation.

Chapter 2: Plant Science.....	12
Introduction	12
Plant Science.....	12
Classification of Plants	13
Plant Kingdom.....	12
Binomial Nomenclature	13
Plant Nomenclature	15
Botany: Plant Parts and Functions	15
Stems	15
Leaves.....	19
Buds.....	23
Roots	24
Flowers.....	25
Fruit.....	28
Seed.....	28
Physiology: Plant Growth and Development.....	28
Photosynthesis	28
Respiration	30
Transpiration.....	30
Environmental Factors	
that Affect Plant Growth	31
Light	31
Temperature	32
Water	33
Nutrition.....	35
Nutrient Outline.....	36
Plant Propagation.....	38
Sexual Propagation	39
See	39
Germination.....	30
Methods of Breaking Dormancy.....	40
Starting seeds.....	41
Transplanting and handling.....	44
Propagation of ferns by spores	45
Asexual Propagation	46
Cuttings	46
Layering	46
Separation.....	49
Division.....	49
Grafting	49
Budding.....	51
Plant Tissue Culture.....	51

Plants exist all around us and are an integral part of our world. Plant science is broad and varied. Some traditional components of plant science are botany, horticulture, agronomy and forestry. Within these disciplines are many other areas of study. For example, botany students might specialize in physiology, genetics or taxonomy. Horticulture students typically study the science of cultivated plants, including ornamental trees and shrubs (landscape horticulture), flowers (floriculture), vegetables (olericulture) and fruit (pomology).

This chapter looks at a broad cross-section of plant science focusing on horticulture, the structure and function of plants and the environmental factors that affect plant growth. Keep in mind that many of these disciplines cross over from gardening into horticulture. In the following sections, sciences such as plant morphology (plant forms and structures), plant physiology (how a plant functions), soil science and plant nutrition, plant pathology (diseases that attack plants) and entomology (insects that feed on plants) are given closer attention.

Plant Science

Plant kingdom

More than 500,000 kinds of plant-like organisms exist in the world. A common definition of a plant is a living organism that contains chlorophyll and can manufacture its own food. Plants

are complex multicellular organisms that almost always photosynthesize. Plants possess a waxy cuticle that reduces water loss and they regulate gases within their stems, leaves and roots through tiny openings called stomata. Plants are generally rooted in the ground. Unlike animals, plants have rigid cell walls, will grow continuously and do not possess a nervous system.

Though things such as fungi, lichens and algae effect horticultural growing systems, for our purposes we will focus on two types of vascular plants: angiosperms and gymnosperms.

Flowering plants are called angiosperms. That word comes from the Greek *angeion* for vessel, and *sperma*, for seed. The name “angiosperm” indicates that seeds are borne inside a vessel known as the fruit. Angiosperms, the flowering plants, are the most abundant and the most familiar to us. As we delve into plant science, the focus will be on angiosperms’ structures and metabolic processes.

Table 2.1. The Plant Kingdom.

Non-vascular:

Mosses Bryophytes – moss plants
Liverworts Bryophytes – moss plants

Vascular:

Horsetails..... Pteridophytes – fern plants
Ferns Pteridophytes – fern plants
Cycads Gymnosperms – naked-seed plants
Conifers Gymnosperms – naked-seed plants
Dicotyledons..... Angiosperms – enclosed-seed plants
Monocotyledons Angiosperms – enclosed-seed plants

Non-flowering plants are called gymnosperms, coming from the Greek *gymnos* for naked, and *sperma* for seed. Gymnosperms are plants that produce seeds in an exposed condition (naked), such as pines and other conifers, cycads and ginkgo.

Other species in the plant kingdom include algae, fungi, mosses, liverworts, horsetails and ferns. These organisms are more primitive (less developed) than the gymnosperms and angiosperms.

There are two groups of flowering plants – the monocotyledons group (monocots), which in-

cludes grasses, lilies and corn; and the dicotyledons group (dicots), which includes beans, marigolds and maple trees. Monocots and dicots differ in their leaf venation, the number of seed leaves and flower parts, and root structures. They also have different physiological traits, which result in different responses to herbicides. For example, broadleaf weed killers kill dandelions (a dicot) but they won’t kill grasses (monocots).

Classification of Plants

Because of the diversity in the plant kingdom, plants are classified using several methods, which assist in recording and communicating information about them. At one time, plants were named descriptively in Latin by using adjectives until enough verbiage was present to allow differentiation among plants. Common names used by botanists and plant collectors for centuries were also a problem because one plant may have several common names. For example, the European white water lily has 245 English, French, German and Dutch names. To eliminate the potential for confusion, Carl von Linne, a Swedish physician, botanist and professor of natural science, developed a naming system in 1753 that we still use today – binomial nomenclature.

Binomial nomenclature

Modern plant classification, or taxonomy, is based on a system of binomial nomenclature – a scientific system that gives a two-part name to each plant or animal. The first name (genus) is followed by a descriptive name (specific epithet). Together, this name identifies a species. First, plants are classified into families based on their flowers and/or reproductive parts because this is the part of the plant least influenced by environmental changes.

Plant families

Genera that share similar flowering and fruiting characteristics are grouped into families. For example, peas belong to a large family called legumes (Fabaceae, formerly Leguminosae). The pea flower is shaped much like the flower of the tree commonly called the redbud (*Cercis canadensis*). All legumes have similar flowers and fruiting structures (pods), though their physical forms may

be vastly different. Other legumes include beans, alfalfa, clover, wisteria, honeylocust, Siberian pea shrub and Kentucky coffeetree.

What do roses have in common with apple? Both are in the same family – Rosaceae. Their fruits are pomes. Plants from the Rosaceae family share susceptibility to many of the same diseases. For example, apple trees and roses get fire blight, and both are susceptible to mildew during humid weather. Other plants in the Rosaceae family include cotoneaster, spirea, quince, pear and mountain ash.

Genus

Once groups of similar plants are categorized into families, the next level of classification is based on their relative likeness to another. This level is called the genus. Plants in the same genus often share not only similar fruits but also similar flowers, roots, stems, buds and leaves. The genus name is always capitalized and in italics. Example: *Quercus* (oak).

Specific epithet

Specific definition comes with the specific epithet. At this level, marked features carried from generation to generation distinguish the group. The specific epithet can be a descriptive, Latinized adjective such as *alba*, which means white, or note the place of origin or honor the founder. Species names are not capitalized, but they are italicized. Example: *Quercus alba* (white oak).

Cultivar

Cultivar names are more defining, but often are not Latinized. Cultivars can be confusing because there may be hundreds of cultivars within each species. A cultivar is a group of plants that is clearly distinguished by certain characteristics (morphological, physiological, cytological or chemical). When the plant is reproduced (sexually or asexually), it retains these distinguishing characteristics. For example, a common maple with red leaves is called 'Crimson King' Norway maple. Its parent has dark green leaves, but this mutation was discovered and propagated for our use. Leaf color, flower color and plant form are obvious reasons a plant mutation may be given a cultivar name. However, plants do not have to have visual differences to gain cultivar status. Perhaps they are simply hardier or more disease resistant. Culti-

var names are always capitalized, in single quotes and not italicized. Example: *Acer platanoides* 'Crimson King.'

Often, grouped or classified plants are based on their use or characteristics. The most commonly used classifications related to use include growth habit, structure or form, leaf retention, climactic adaptation and use. Scientific or botanical classification is also used and is often preferred when exactness is needed.

Growth Habit – plants can be classed as annual, perennial or biennial. **Annuals** complete their life cycle in one year, developing from seed to flower, then reseeding and dying. **Perennials** continue to grow for several years. Horticulturists usually use the term perennial to describe the many herbaceous plants used as ornamentals in the landscape and live for several years.

Biennials are plants that produce foliage the first year, flowers the second year, then dies. Biennials usually need to go through a cold dormancy to trigger the development of flowers the second year.

Realize that a plant that is truly perennial in one part of the country may behave like an annual in another because it is not adapted to the environmental conditions there; these types of plants are often referred to as tender perennials and are often used as bedding plants or for seasonal display.

Structure or Form – the structure, size or form of a plant is another broad way to classify plants. Plants that have dense, fibrous, sturdy stems that don't die to the ground each year are woody, whereas those that have soft, fleshy stems that are usually killed to the ground each winter are herbaceous.

Woody plants can further be classified by their form as a vine, shrub or tree. Vines trail or creep along the ground unless offered support. Short, upright plants with multiple main stems are considered as shrubs, and tall woody plants with a single or a few main stems are usually considered trees.

Leaf Retention – plants that retain their leaves year round are evergreen. Evergreens do shed old leaves regularly, but retain the majority throughout the year. Evergreens can further be classified into narrow-leaf or needle-leaf (e.g., pine, spruce) or broadleaf (e.g., most holly, southern magnolia).

Climatic Adaptation – the environment in which a plant grows is another way to classify plants. Conditions such as shade, sun, drought, wet soils, hot or cold temperatures, infertile soils, air pollu-

tion, road or sea salts, acidity and alkalinity are often used for classification and can be helpful when selecting plants.

Uses

Gardeners tend to group plants by their horticultural uses: fruits, vegetables, flowers, trees, shrubs, turf and so on. These categories are a convenient way to think and learn about plants.

Botany: Plant Parts and Functions

The parts of a plant can be divided into two groups, sexual reproductive parts and vegetative parts. Sexual reproductive parts are those involved in the production of seed. They include flower buds, flowers, fruit and seeds. The vegetative parts include leaves, roots, leaf buds and stem. Although the vegetative parts are not directly involved in sexual reproduction, they are often used in asexual or vegetative forms of reproduction, such as cuttings.

Stems

Stems are structures that support buds and leaves, and serve as conduits for carrying water, minerals and sugars. The three major internal

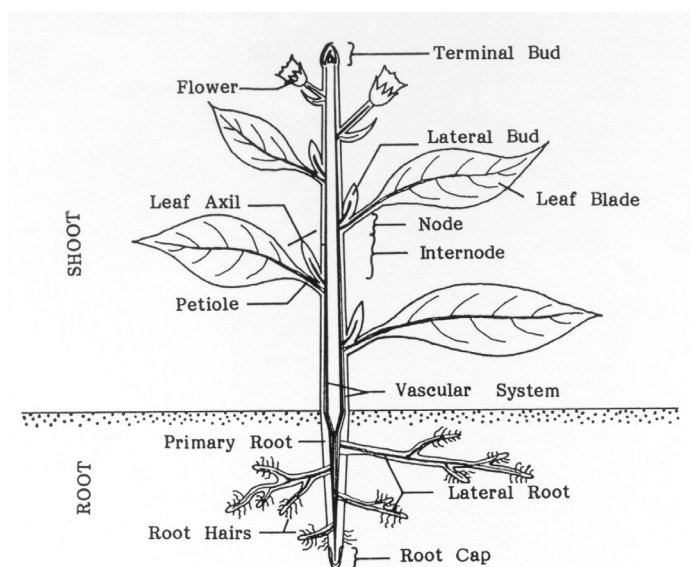

Figure 2.1. Principal parts of a vascular plant.

parts of a stem are the xylem, phloem and cambium. The xylem and phloem are the major components of a plant's vascular system. The **vascular system** transports food, water and minerals and offers support for the plant. **Xylem** tubes conduct water and minerals, while **phloem** tubes conduct food.

The vascular systems of monocots and dicots differ. While both contain xylem and phloem, they are arranged differently. In the stem of a monocot, the xylem and phloem are paired into **bundles**; these bundles are dispersed throughout the stem. But in the stem of a dicot, the vascular system forms **rings** inside the stem. The ring of phloem is near the bark of external cover of the stem and is a component of the bark in mature stems. The xylem forms the inner ring; it is the sapwood and heartwood in woody plants. The difference in the vascular system of the two groups is of practical interest to the horticulturist because certain herbicides are specific to either monocots or dicots. An example is 2,4-D, which only kills dicots.

The **cambium** is a meristem, which is a site of cell division and active growth. It is located between the xylem and phloem inside the bark of a stem and is the tissue responsible for a stem's increase in girth, as it produces both the xylem and phloem tissues.

Stems may be long, with great distances between leaves and buds (branches of trees, runners on strawberries), or compressed, with short distances between buds or leaves (fruit spurs, crowns of strawberry plants, dandelions). Stems can be above the ground like the most familiar stems or below the ground (potatoes, tulip bulbs). All stems must have buds or leaves present to be classified as stem tissue.

An area of the stem where leaves are located is called a **node**. Nodes are areas of great cellular

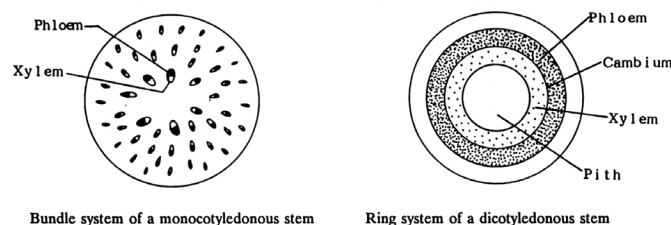
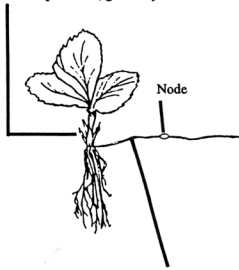
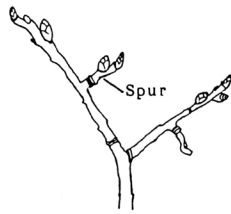

Figure 2.2. Cross-section of a stem.

A crown is a region of compressed stem tissue from which new shoots are produced, generally found near the surface of the soil.



A spur is a compressed fruiting branch.



A runner is a type of stolon. It is a specialized stem that grows on the soil surface and forms a new plant at one or more of its nodes.

A branch is a stem which is more than one year old.

Figure 2.3. Above ground stem modifications.

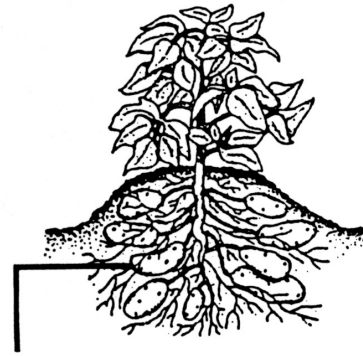

A tuber is an enlarged portion of an underground stem.



A rhizome is a specialized stem which grows horizontally at or just below the soil surface and acts as a storage organ and means of propagation in some plants.

Figure 2.4. Below ground stem modifications.

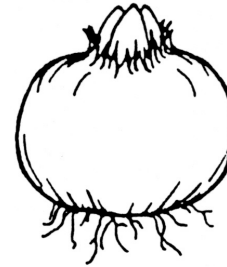

A bulb is composed of a short stem plate, closely spaced buds, and fleshy leaves.

Figure 2.7. Tuber (top) and bulb (bottom).



Figure 2.5. A corm is a compressed stem with reduced scaly leaves.

activity and growth, where auxiliary buds develop into leaves or flowers. The area between nodes is called the **internode**.

The length of an internode may depend on many factors. Decreasing fertility will decrease internode length. Internode length varies with the season. Too little light will result in a long internode, causing a spindly stem. This situation is known as stretch or etiolation.

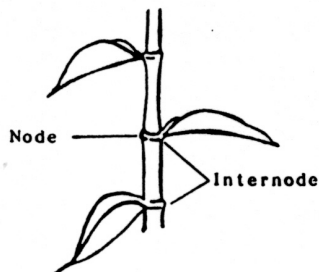

Figure 2.6. Parts of a stem.

Growth produced early in the season has the greatest internode length. Internode length decreases as the growing season nears its end. Vigorously growing plants tend to have greater internode lengths than less vigorous plants. Internode length will vary with competition from surrounding stems or developing fruit. If the energy for a stem has to be divided between three or four stems, or if the energy is diverted into fruit growth, internode length will be shortened.

Modified Stems. Although typical stems are aboveground trunks and branches, there are modified stems, which can be found aboveground and belowground. The aboveground modified stems are crowns, stolons and spurs, and the belowground stems are bulbs, corms, rhizomes and tubers.

Above-ground stems

Crowns (strawberries, dandelions, African violets) are compressed stems having leaves and flowers on short internodes.

Spurs are short, stubby, side stems that arise from the main stem and are common on such fruit trees as pears, apples and cherries, where they

may bear fruit. If severe pruning is done close to fruit-bearing spurs, the spurs can revert to a long, nonfruiting stem.

A **stolon** is a horizontal stem that is fleshy or semi-woody and lies along the top of the ground. Strawberry runners are examples of stolons. Remember, all stems have nodes and buds or leaves. The leaves on strawberry runners are small, but are located at the nodes, which are easy to see. The nodes on the runner are the points where roots begin to form. The spider plant has stolons.

Belowground stems such as the potato tuber, the tulip bulb and the iris rhizome are underground stems that store food for the plant.

The **tuber**, like any other stem, has nodes that produce buds. The eyes of a potato are actually the nodes on the stem. Each eye contains a cluster of buds.

Rhizomes are similar to stolons, but grow underground. Some rhizomes are compressed and fleshy such as those of iris. They can also be slender with elongated internodes such as Bermuda grass. Johnsongrass is a hated weed prin-

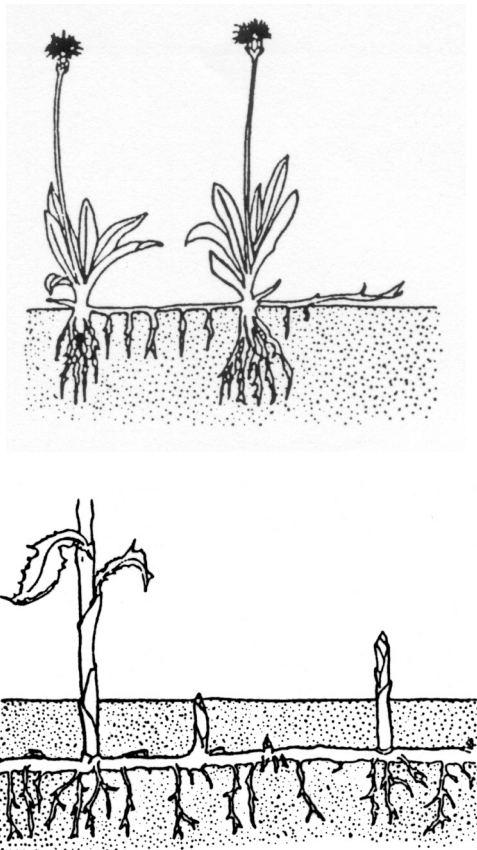

Figure 2.8. Stolon (top) and rhizome (bottom).

cipally because of the spreading capability of its rhizomes.

Tulips, lilies, daffodils and onions are plants that produce bulbs – shortened, compressed, underground stems surrounded by fleshy scales (leaves) that envelop a central bud located at the tip of the stem. If you cut through the center of a tulip or daffodil bulb in November, you can see all the flower parts in miniature within the bulb.

Many bulbs require a period of low-temperature exposure before they begin to send up the new plant. Both the temperature and length of this treatment are of critical importance to commercial growers who force bulbs for holidays.

Corms are not the same as bulbs. They have shapes similar to bulbs, but do not contain fleshy scales. A corm is a solid, swollen stem whose scales have been reduced to a dry, leaf-like covering.

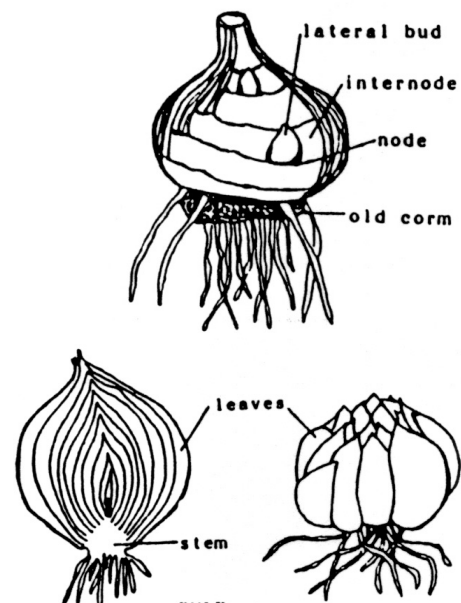

Figure 2.9. Parts of a corm (top) and bulb (below).

Some plants produce a modified stem that is referred to as a tuberous stem. Examples are tuberous begonia and cyclamen. The stem is shortened, flattened, enlarged and underground. Buds and shoots arise from the crown and fibrous roots are found on the bottom of the tuberous stem.

In addition, some plants, such as the dahlia and the sweet potato, produce an underground storage organ called a tuberous root, which is often confused with bulbs and tubers. However,

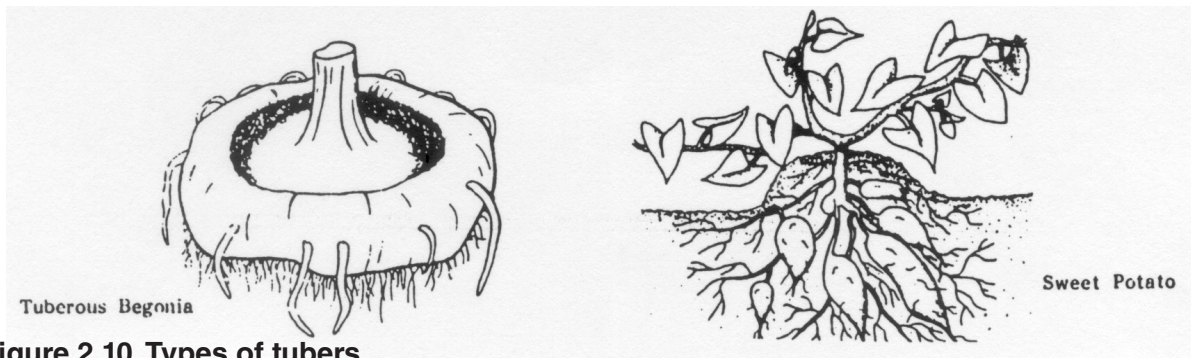
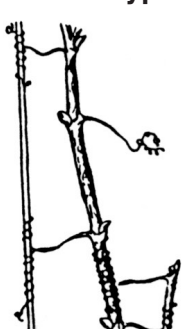

Figure 2.10. Types of tubers.



Some vines have tendrils that wrap around any type of support.



Twining vines climb by winding their stems around any available support.

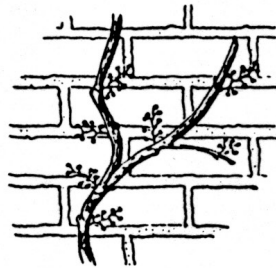

Clinging vines climb by means of tendrils with disk-like adhesive tips that attach to any surface.

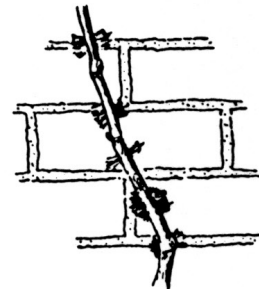

Other climbing vines attach themselves to surfaces with small serial rootlets along the stem.

Figure 2.11. Types of vines.

these are roots, not stems, and have neither nodes nor internodes.

Stems are commonly used for plant propagation. Aboveground stems can be divided into sections containing internodes and nodes. They are referred to as cuttings, and will produce roots to form a new plant. Belowground stems are also good propagative tissues: rhizomes can be divided into pieces; bulbs form small bulblets at the base of the parent bulb; cormels are miniature corms that form under the parent corm; and tubers can be cut into pieces containing eyes and nodes. All of these will produce new plants.

It sometimes may be difficult to distinguish between roots and stems, but one sure way is to look for the presence of nodes. Stems have nodes; roots do not.

Types of stems

A **shoot** is a young stem with leaves present. A **twig** is a stem that is less than one year old and has no leaves, since it is still in the winter-dormant stage. A **branch** is a stem, which is more than one year old, and typically has lateral stems. A **trunk** is a main stem of a woody plant. Most trees have a single trunk.

Trees are perennial woody plants, usually have one main trunk and are usually more than 12 feet tall at maturity.

Shrubs are perennial woody plants, but have one or several main stems and are usually less than 12 feet tall at maturity.

A **vine** is a plant that develops long, trailing stems that grow along the ground unless they are supported by another plant or structure. Some twining vines circle their support clockwise (hops or honeysuckle), while others circle counter-clockwise (pole beans or Dutchman's pipe vine). Climbing vines are supported by aerial roots (English ivy or poison ivy), slender tendrils which encircle the supporting object (cucumber, gourds, grapes and passion-flowers) or tendrils with adhesive tips (Virginia creeper and Japanese creeper).

Texture and growth of stems

Woody stems contain relatively large amounts of hardened xylem tissue in the central core and are typical of most tree fruits and ornamental trees and shrubs.

A **cane** is a stem that has a relatively large pith (the central strength-giving tissue of stem) and usually lives only one to two years. Examples of

plants with canes include rose, grape, blackberry and raspberry.

Herbaceous or succulent stems contain only small amounts of xylem tissue and usually live for only one growing season. If the plant is perennial, it will develop new shoots from the root.

Plants are classified by the number of growing seasons required to complete a life cycle. **Annals** pass through their entire life cycle from seed germination to seed production in one growing season and then die.

Biennials are plants that start from seeds and produce vegetative structures and food storage organs the first season. During the first winter, a hardy evergreen rosette of basal leaves persists. During the second season, flowers, fruit and seeds develop to complete the life cycle. The plant then dies. Carrots, beets, cabbage, celery and onions are biennial plants. Hollyhock, Canterbury Bells and Sweet William are biennials, which are commonly grown for their attractive flowers.

Plants that typically develop as biennials may, in some cases, complete the cycle of growth from seed germination to seed production in only one growing season. This situation occurs when drought, variations in temperature or other climatic conditions cause the plant to physiologically pass through the equivalent of two growing seasons, in a single growing season. This phenomenon is referred to as **bolting**.

Perennial plants live for many years, and after reaching maturity, typically produce flowers and seeds each year. Perennials are classified as herbaceous if the top dies back to the ground each winter and new stems grow from the roots each spring. They are classified as woody if the top persists, as in shrubs or trees.

Stems as food

The edible portion of cultivated plants such as asparagus and kohlrabi is an enlarged succulent stem. The edible parts of broccoli are composed of stem tissue, flower buds and a few small leaves. The edible part of potato is a fleshy underground stem called a tuber. Although the name suggests otherwise, the edible part of the cauliflower is proliferated stem tissue.

Leaves

Parts of a leaf

The **blade** of a leaf is the expanded, thin structure on either side of the midrib. The blade is usually the largest and most conspicuous part of a leaf. The **petiole** is the stalk that supports the leaf blade; it varies in length and may be lacking entirely in some cases where the leaf blade is described as sessile or stalkless.

Parts of Leaves

The principal function of leaves is to absorb sunlight for the manufacturing of plant sugars in a process called photosynthesis. Leaves develop as a flattened surface to present a large area for efficient absorption of light energy. The leaf is supported away from the stem by a stem-like appendage called a petiole. The base of the petiole is attached to the stem at the node. The small angle formed between the petiole and the stem is called the leaf axil. An active or dormant bud or cluster of buds is usually located in the axil.

The leaf blade is composed of several layers. On the top and bottom is a layer of thickened, tough cells called the epidermis. The primary function of the epidermis is protection of leaf tissue. The way in which the cells in the epidermis are arranged determines the texture of the leaf surface. Some leaves have hairs that are an extension of certain cells of the epidermis. The African violet has so many hairs that the leaf feels like velvet.

Part of the epidermis is the cuticle, which is composed of a waxy substance called cutin. Cutin protects the leaf from dehydration and prevents penetration of some diseases. The amount of cutin is a direct response to sunlight, increasing with increasing light intensity. For this reason, plants grown in the shade should be moved into full sunlight gradually, over a period of a few weeks, to al-

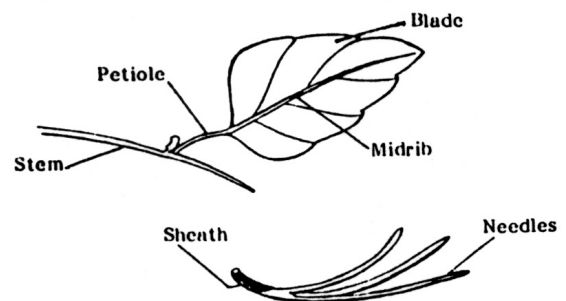

Figure 2.12. Broadleaf (top) and conifer leaf (bottom).

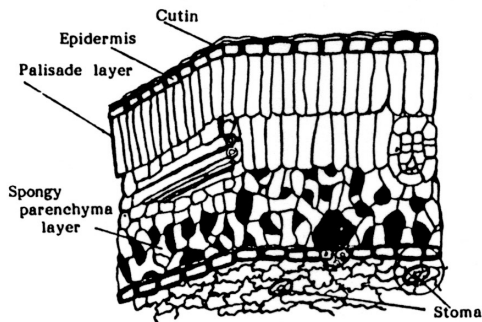
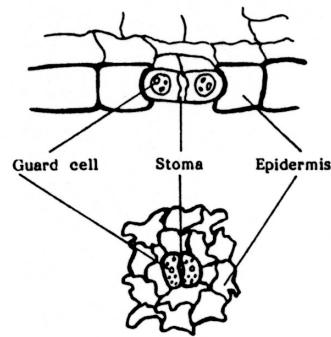

Figure 2.13. Leaf parts.

low the cutin layer to build and to protect the leaves from the shock of rapid water loss or sunscald. The waxy cutin also repels water and can shed pesticides if spreader-sticker agents or soaps are not used. This is the reason many pesticide manufacturers include some sort of spray additive to adhere to or penetrate the cutin layer.

On the underside of leaves, some epidermal cells are capable of opening and closing. These cells guard the interior of the leaf and regulate the passage of water, oxygen and carbon dioxide through the leaf. These regulatory cells are called guard cells. They protect openings in the leaf surface called stoma. The opening and closing of the cells is determined by the weather. Conditions that would cause large water losses from plants (high temperature, low humidity) stimulate guard cells to close. Mild weather conditions leave guard cells in an open condition. Guard cells will close in the absence of light.

The middle layer of the leaf is the mesophyll and is located between the upper and lower epidermis. This is the layer in which photosynthesis occurs. The mesophyll is divided into a dense upper layer, called the palisade, and a spongy lower layer that contains a great deal of air space, called the parenchyma layer. The cells in these two layers contain chloroplasts, which are the actual site of the photosynthetic process.



Types of leaves

A number of rather distinct types of leaves occur on plants. Leaves, commonly referred to as foliage, are the most common and conspicuous. Leaves serve as the manufacturing centers where the photosynthetic activity of the plant occurs. **Scale leaves** or cataphylls are found on rhizomes and are also the small, leathery, protective leaves that enclose and protect buds. **Seed leaves or cotyledons** are modified leaves found on the embryonic plant and commonly serve as storage organs. **Spines and tendrils**, as found on barber-y and pea, are specialized modified leaves that protect the plant or assist in supporting the stems. **Storage leaves**, as are found in bulbous plants and succulents, serve as food storage organs. Other specialized leaves include **bracts**, which are often brightly colored. The showy structures on dogwoods and poinsettias are bracts, not petals.

Venation of leaves

The vascular bundles from the stem extend through the petiole and spread out into the blade. The term **venation** refers to the patterns in which the veins are distributed in the blade. Two principal types of venation are parallel-veined and net-veined.

Parallel-veined leaves are those in which numerous veins run essentially parallel to each other and are connected laterally by minute, straight



Parallel



Pinnate

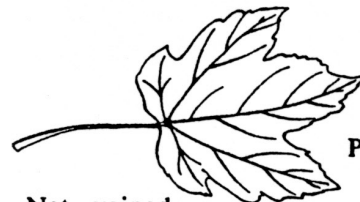

Net veined

Palmate

Figure 2.14. Types of venation.

veinlets. Possibly the most common type of parallel-veining is that found in plants of the grass family where the veins run from the base to the apex of the leaf. Another type of parallel-veination is found in plants such as banana, calla and pickerel-weed, where the parallel veins run laterally from the midrib. Parallel-veined leaves occur on plants that are part of the monocotyledon group.

Net-veined leaves, also called reticulate-veined, have veins that branch from the main rib(s) and then subdivide into finer veinlets, which then unite in a complicated network. This system of enmeshed veins gives the leaf more resistance to tearing than most parallel-veined leaves. Net-veination may be either pinnate or palmate. In pinnate venation, the veins extend laterally from the midrib to the edge, as in apple, cherry and peach. Palmate venation occurs in grape and maple leaves, where the principal veins extend outward, like the ribs of a fan, from the petiole near the base of the leaf blade. Net-veined leaves occur on plants that are part of the dicotyledon group.

Using leaves to identify plants

Leaves are useful in identifying species and varieties of horticultural plants. The shape of the leaf blade and the type of margin are of major im-

portance as identifying characteristics. **Simple** leaves are those in which the leaf blade is a single continuous unit. A **compound leaf** is composed of several separate leaflets arising from the same petiole.

A deeply lobed leaf may appear similar to a compound leaf, but if narrow bands of blade tissue connect the leaflets, it may be classified as a simple leaf. If the leaflets have separate stalks, and particularly if these stalks are jointed at the point of union with the main leaf-stalk, the leaf is considered to be compound. Some leaves may be doubly compound, having divisions of the leaflets.

Shape of the leaf blade: The following are some common shapes found in leaves and leaflets.

- Linear:* Narrow, several times longer than wide; approximately the same width throughout.
- Lanceolate:* Longer than wide; tapering toward the apex and base.
- Elliptical:* Two to three times longer than wide; tapering to an acute or rounded apex and base.
- Ovate:* Egg-shaped, basal portion wide; tapering toward the apex.

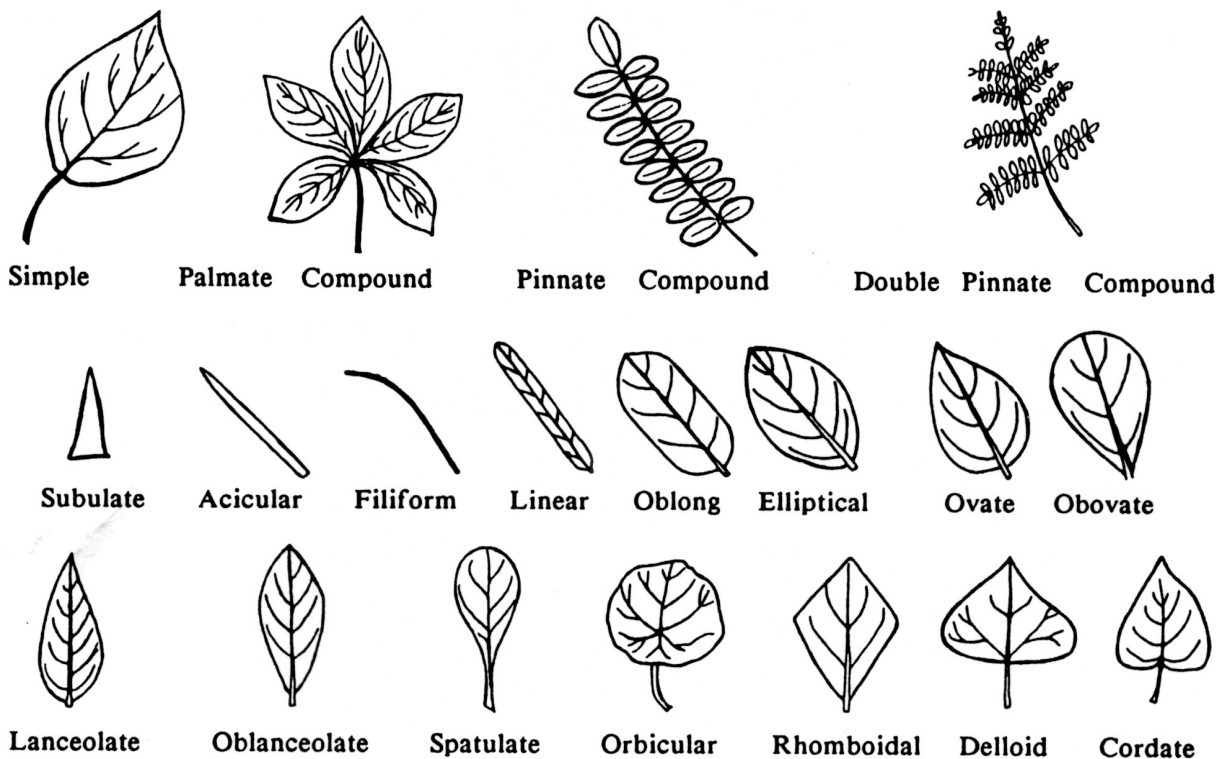

Figure 2.15. Types of leaves.

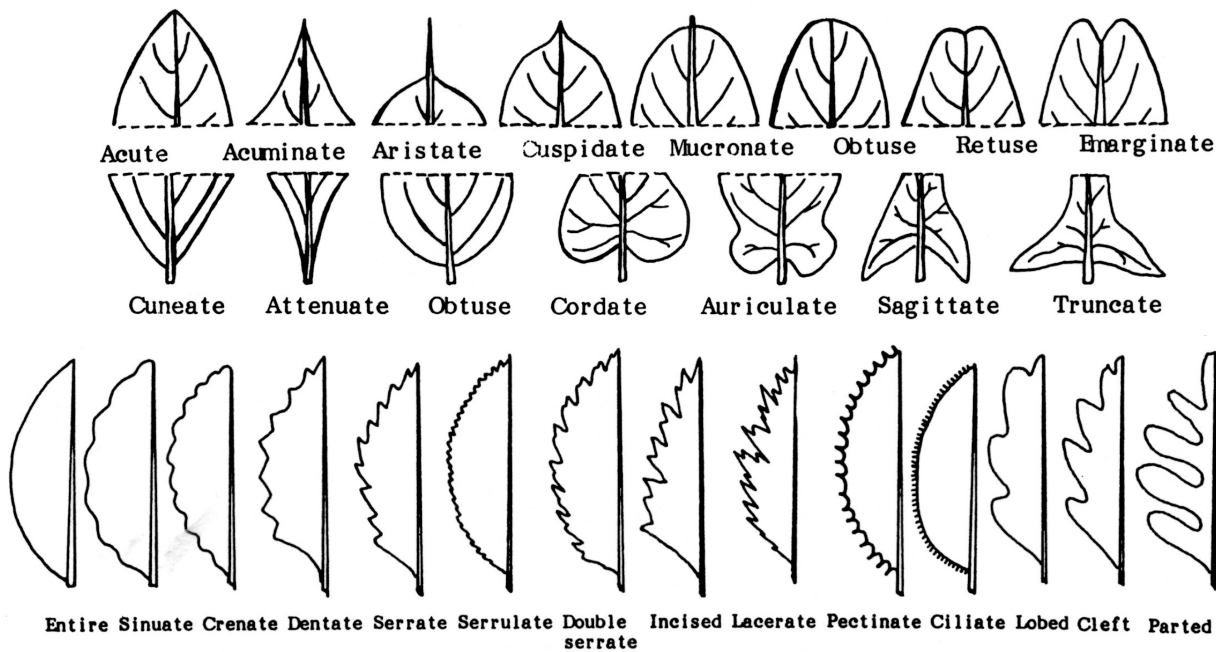

Figure 2.16. Leaf shapes.

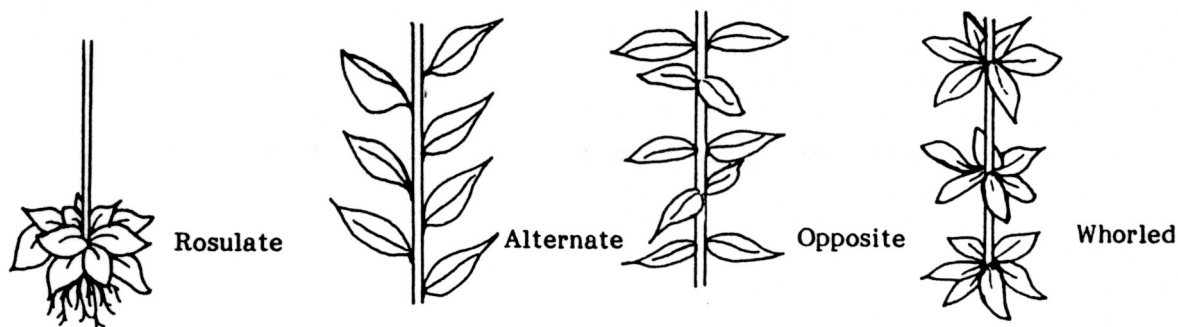

Figure 2.17. Arrangement of leaves on a stem.

Cordate: Heart-shaped, broadly ovate; tapering to an acute apex, with the base turning in and forming a notch where the petiole is attached.

Shape of the leaf apex and base: The following are common shapes found in leaves.

- Acuminate:** Tapering to a long, narrow point.
- Acute:** Ending in an acute angle, with a sharp, but not acuminate, point.
- Obtuse:** Tapering to a rounded edge.
- Sagittate:** Arrowhead-shaped, with two pointed lower lobes.
- Truncate:** Having a relatively square end.

Leaf margins: Studying leaf margins is especially useful in the identification of certain varieties of fruit plants.

- Entire:** A smooth edge with no teeth or notches.
- Serrate:** Having small, sharp teeth pointing toward the apex.

Dentate: Having teeth ending in an acute angle, pointing outward.

- Crenate:** Having rounded teeth.
- Sinuate:** Having a pronounced sinuous or wavy margin.

Incised: Margin cut into sharp, deep, irregular teeth or incisions.

Lobed: Incisions extend less than halfway to the midrib.

Cleft: Incisions extend more than halfway to the midrib.

Leaf arrangement along a stem: The various ways leaves are arranged along a stem are also used to help identify plants. **Rosulate** arrangement is one in which the basal leaves form a rosette around the stem with extremely short nodes. **Opposite** leaves are positioned across the stem from each other, two leaves at each node. **Alternate** or spiral leaves are arranged in alternate

steps along the stem with only one leaf at each node. **Whorled** leaves are arranged in circles along the stem.

Leaves as food

The leaf blade is the principal edible part of several horticultural crops including chive, collard, dandelion, endive, kale, leaf lettuce, mustard, parsley, spinach and Swiss chard. The edible part of leek, onion and Florence fennel is a cluster of fleshy leaf bases. The petiole of the leaf is the edible product in celery and rhubarb. In plants like Brussels sprout, cabbage and head lettuce, the leaves – in the form of a large, naked bud – are the edible product.

Buds

A **bud** is an undeveloped shoot from which embryonic leaves or flower parts arise. The buds of trees and shrubs of the temperate zone typically develop a protective outer layer of small, leathery bud scales. Annual plants and herbaceous perennials have naked buds in which the outer leaves are green and somewhat succulent.

Buds of many plants require exposure to a certain number of days below a critical temperature (rest) before they will resume growth in the spring.

This time period varies for different plants. The flower buds of forsythia require a relatively short rest period and will grow at the first sign of warm weather. Many peach varieties require from 700 to 1,000 hours of temperatures below 45 F (7 C) before they will resume growth. During rest, dormant buds can withstand very low temperatures, but after the rest period is satisfied, buds become more susceptible to weather conditions, and can be damaged easily by cold temperatures or frost.

A **leaf bud** is composed of a short stem with embryonic leaves, with bud primordia in the ax-

ils and at the apex. Such buds develop into leafy shoots. Leaf buds are often less plump and more pointed than flower buds.

A **flower bud** is composed of a short stem with embryonic flower parts. In some cases, the flower buds of plants that produce fruit crops of economic importance, are called fruit buds. This terminology is objectionable because, although flowers have the potential for developing into fruit, this development may never occur because of adverse weather conditions, lack of pollination or other unfavorable circumstances. The structure is a flower bud, and should be so designated, since it may never set fruit.

Types of buds

Buds are named for the location they inhabit on the stem surface. **Terminal buds** are those located at the apex of a stem. **Lateral buds** are borne on the sides of the stem. Most lateral buds arise in the axil of a leaf and are called **axillary buds**. In some instances, more than one bud is formed. **Adventitious buds** are those that arise at sites other than in the terminal or axillary position. Adventitious buds may develop from the internode of the stem, at the edge of a leaf blade, from callus tissue at the cut end of a stem or root, or laterally from the roots of a plant.

Buds as food

Enlarged buds or parts of buds form the edible portion of some horticultural crops. Cabbage and head lettuce are examples of unusually large terminal buds. Succulent axillary buds of Brussels sprouts become the edible part of this plant. In the case of globe artichoke, the fleshy basal portion of the bracts of the flower bud is eaten along with the solid stem portion of the bud. Broccoli is the most important horticultural plant in which edible flower

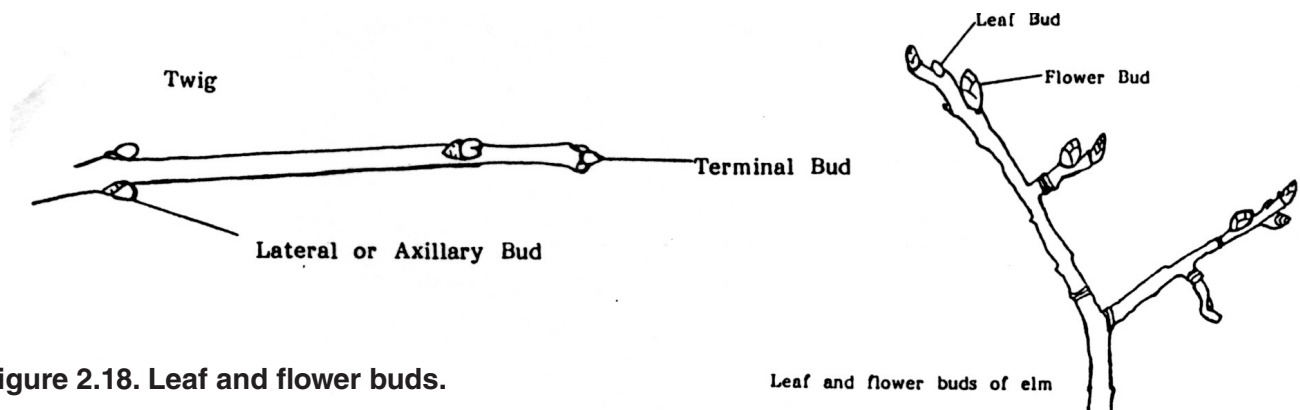

Figure 2.18. Leaf and flower buds.

Leaf and flower buds of elm

buds are consumed. In this case, portions of the stem as well as small leaves associated with the flower buds are eaten.

Roots

A thorough knowledge of plant systems is essential if their growth, flowering and fruiting responses are to be understood. The structure and growth habits of roots have a pronounced effect on the size and vigor of the plant, method of propagation, adaptation to certain soil types and response to cultural practices and irrigation. The roots of certain vegetable crops are important as food.

Roots typically originate from the lower portion of a plant or cutting. They possess a root cap, have no nodes and never bear leaves or flowers directly. The principal functions of roots are to absorb nutrients and moisture, to anchor the plant in the soil, to furnish physical support for the stem and to serve as food storage organs. In some plants, they may be used as means of propagation.

Types of roots

A **primary** (radicle) root originates at the lower end of the embryo of a seedling plant. A **taproot** is formed when the primary root continues to elongate downward into the soil and becomes the central and most important feature of the root system, with a somewhat limited amount of secondary branching. Some trees, especially nut trees like pecan, have a long taproot with very few lateral or fibrous roots. This makes them difficult to transplant and necessitates planting only in deep, well-drained soil. The taproot of carrot, parsnip and salsify is the principal edible part of these crops.

A **lateral**, or secondary, root is a side or branch root, which arises from another root.

A **fibrous** root system is one in which the primary root ceases to elongate, leading to the development of numerous lateral roots, which branch repeatedly and form the feeding root system of the plant. A fibrous root is one that remains small in

diameter because of a lack of significant cambial activity. One factor, which causes shrubs and dwarf trees to remain smaller than standard trees, is the inactivity of the cambium tissue in the roots.

If plants that normally develop a taproot are undercut so the taproot is severed early in the plant's life, the root will lose its taproot characteristic and develop a fibrous root system. This is done commercially in nurseries so trees, which naturally have taproots, will develop a compact, fibrous root system. This allows a higher rate of transplanting success.

The quantity and distribution of plant roots is very important because these two factors have a major influence on the absorption of moisture and nutrients. The depth and spread of the roots is dependent on the inherent growth characteristics of

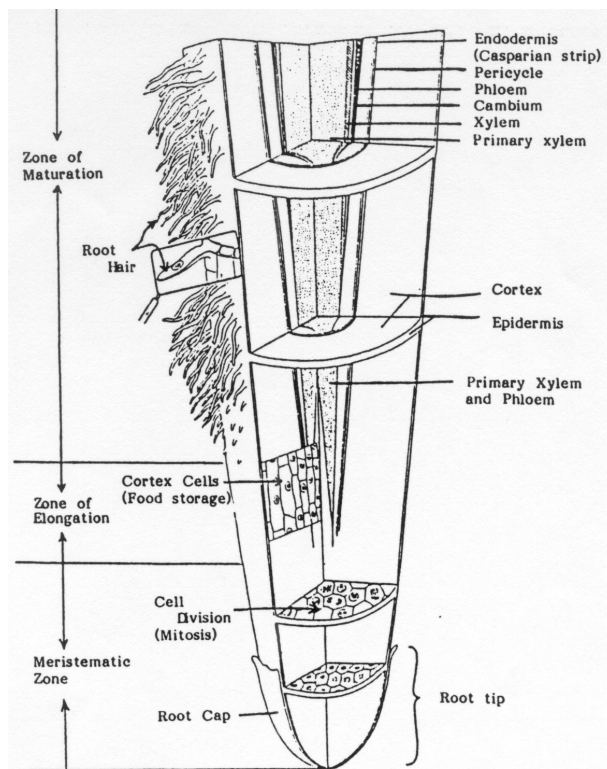
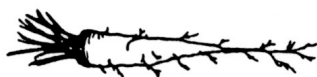

Figure 2.20. Root structure.



Taproot of Carrot



Fibrous Root of Grass

Figure 2.19. Types of roots.

the plant and the texture and structure of the soil. Roots will penetrate much deeper in a loose, well-drained soil than in a heavy, poorly-drained soil. A dense, compacted layer in the soil will restrict or stop root growth.

During early development, a seedling plant absorbs nutrients and moisture from the few inches of soil surrounding it. Therefore, the early growth of most horticultural crops that are seeded in rows benefits from band applications of fertilizer placed several inches to each side and slightly below the seeds.

As plants become well established, the root system develops laterally and usually extends far beyond the spread of the branches. For most cultivated crops, roots meet and overlap between the rows. The greatest concentration of fibrous roots occurs in the top foot of soil, but significant numbers of laterals may grow downward from these roots to provide an effective absorption system several feet deep.

Parts of a root

Internally, there are three major parts of a root. The **meristem** is at the tip and manufactures new cells; it is an area of cell division and growth. Behind it is the **zone of elongation**, in which cells increase in size through food and water absorption. These cells, by increasing in size, push the root through the soil. The third major root part is the **maturation zone**, in which cells undergo changes to become specific tissues such as epidermis, cortex or vascular tissue. The **epidermis** is the outermost layer of cells surrounding the root. These cells are responsible for the absorption of water and minerals dissolved in water. **Cortex** cells are involved in the movement of water from the epidermis and in food storage. **Vascular tissue** is located in the center of the root and conducts food and water.

Externally, there are two areas of importance; **root hairs** are found along the main root and perform much of the actual work of water/nutrient absorption. The **root cap** is the outermost tip of the root, and consists of cells that are sloughed off as the root grows through the soil. The root cap covers and protects the meristem.

Roots as food

The enlarged root is the edible portion of several vegetable crops. The sweet potato is a swollen

root, called a tuberous root, which serves as a food storage area for the plant. Carrot, parsnip, salsify and radish are elongated taproots.

Flowers

The sole function of the flower, which is generally the showiest part of the plant, is sexual reproduction. Its attractiveness and fragrance have not evolved to please man, but to ensure the continuance of the plant species. Fragrance and color are devices to attract pollinators – insects that play an important role in the reproductive process.

The classification of flowers and/or reproductive parts of the plant to give plants a genus and specific epithet name. This has proven to be the best system, since flowers are the plant part least influenced by environmental changes. For this reason, knowledge of the flower and its parts is essential to plant identification.

Parts of the flower

As the reproductive part of the plant, the flower contains the male pollen and/or the female ovule plus accessory parts such as petals, sepals and nectar glands.

Sepals are small, green, leaf-like structures on the base of the flower that protect the flower bud. The sepals collectively are called the calyx.

Petals are highly colored portions of the flower. They may contain perfume as well as nectar glands. The number of petals on a flower is often used in the identification of plant families and genera. The petals collectively are called the corolla. Flowers of dicots typically have sepals and/or petals in multiples of four or five. Monocots typically have these floral parts in multiples of three.

The **pistil** is the female part of the plant. It is generally shaped like a bowling pin and located in the center of the flower. It consists of the stig-

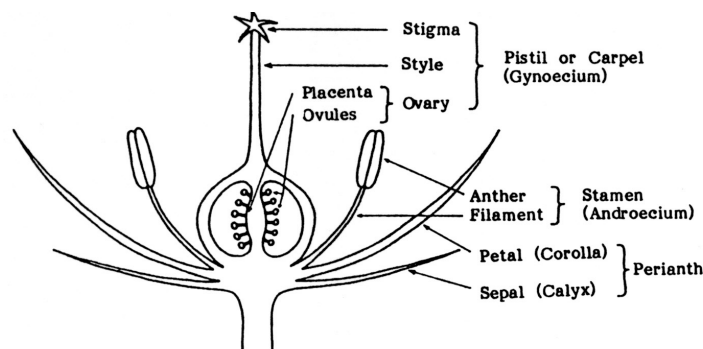

Figure 2.21. Parts of a flower.

ma, style and ovary. The stigma is located at the top, and is connected to the ovary by the style. The ovary contains the eggs, which reside in the ovules. After the egg is fertilized, the ovule develops into a seed.

The **stamen** is the male reproductive organ. It consists of a pollen sac (anther) and a long, supporting filament. This filament holds the anther, which contains pollen in position so the pollen may be dispersed by wind or carried to the stigma by insects or birds.

Types of flowers

If a flower has a stamen, pistil, petals and sepals, it is called a **complete flower**. If one of these parts is missing, the flower is designated **incomplete**.

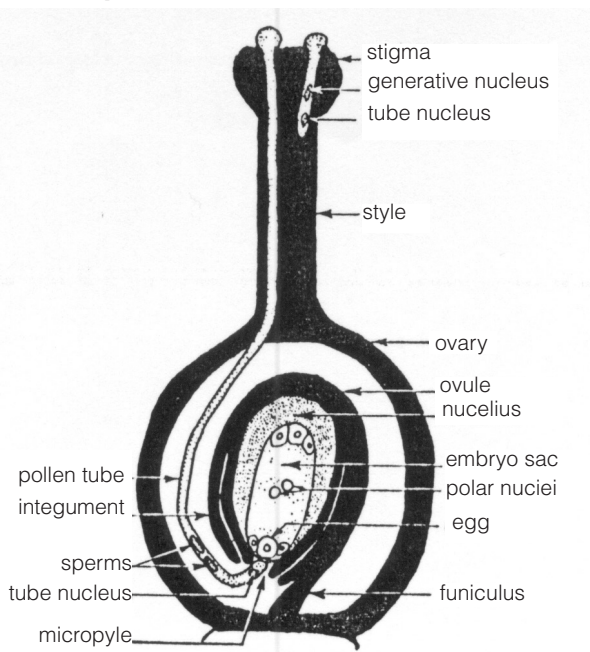

Figure 2.22. Cross-section of a flower.

If a flower contains functional stamens and pistils, it is called a **perfect flower**. (Stamen and pistils are considered the essential parts of a flower). If either of the essential parts is lacking, the flower is **imperfect**.

Pistillate (female) flowers are those that possess a functional pistil(s), but lack stamens. **Staminate** (male) flowers contain stamens, but no pistils.

Because cross-fertilization combines different genetic material and produces stronger seed, cross-pollinated plants are usually more successful than self-pollinated plants. Consequently, more plants reproduce by cross-pollination than self-pollination.

As previously mentioned, there are plants that bear only male flowers (staminate plants) or bear only female flowers (pistillate plants). Species in which the sexes are separated into staminate and pistillate plants are called **dioecious**. Most holly trees are dioecious; therefore, to obtain berries, it is necessary to have a female tree. **Monoecious** plants are those that have separate male and female flowers on the same plant. Corn plants and pecan trees are examples. Some plants bear only male flowers at the beginning of the growing season, but later develop flowers of both sexes; examples are cucumbers and squash.

How seeds form

Pollination is the transfer of pollen from an anther to a stigma. This may occur by wind or by pollinators. Wind-pollinated flowers lack showy floral parts and nectar, since they don't need to attract a pollinator. Flowers are brightly colored or patterned and contain a fragrance or nectar when they must attract insects, animals or birds. In the process of searching for nectar, these pollinators

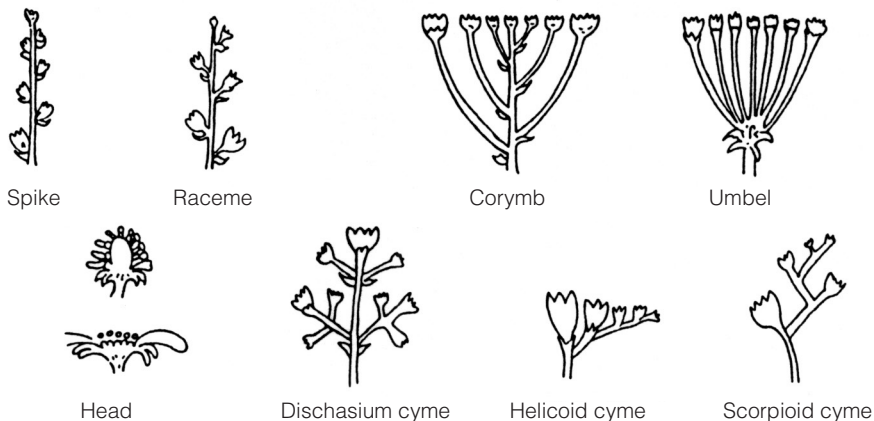

Figure 2.23. Types of flowers.

will transfer pollen from flower to flower. If the pollen is transferred to stigmas of flowers on the same plant, self-pollination results; if it is transferred to flowers on a different plant, cross-pollination occurs. Cross-pollination brings about a combination of genes from two parents, resulting in a greater variety of offspring than with self-pollination. The increased variability of offspring may result in a greater adaptability to different environments, a feature of evolutionary advantage to a species.

The stigma contains a chemical, which excites the pollen, causing it to grow a long tube, down the inside of the style, to the ovules inside the ovary. The sperm is released by the pollen grain and fertilization typically occurs. **Fertilization** is the union of the male sperm nucleus (from the pollen grain) and the female egg (in the ovule). If fertilization is successful, the ovule will develop into a seed.

Types of inflorescences

Some plants bear only one flower per stem and are called **solitary flowers**. Other plants produce an **inflorescence**, a term that refers to a cluster of flowers and how they are arranged on a floral stem. Most inflorescences may be classified into two groups, racemes and cymes.

In the **racemose** group, the florets, which are individual flowers in an inflorescence, bloom from the bottom of the stem and progress toward the top. Some examples of racemose inflorescence include spike, raceme, corymb, umbel and head. A **spike** is an inflorescence in which many stemless florets are attached to an elongated flower stem, or peduncle, an example being gladiolus. A **raceme** is similar to a spike, except the florets are borne on small stems attached to the peduncle. An example of a raceme inflorescence is the snapdrag-

on. A **corymb** is made up of florets whose stalks and pedicels are arranged at random along the peduncle in such a way that the florets create a flat, round top. Yarrow has a corymb inflorescence. An **umbel** is similar except that the pedicels all arise from one point on the peduncle. Dill has an umbel inflorescence. A **head**, or composite, inflorescence is made up of numerous stemless florets which is characteristic of daisy inflorescence.

In the **cyme** group, the top floret opens first and blooms downward along the peduncle. A **dichasium cyme** has florets opposite each other along the peduncle. Baby's breath inflorescence is an example. A **helicoïd cyme** is one in which the lower florets are all on the same side of the peduncle, examples being freesia and statice inflorescences. A **scorpioid cyme** is one in which the florets are alternate to each other along the peduncle. Examples are tomato and potato inflorescences.

Fruit

Parts of fruit

Fruit consists of the fertilized and mature ovules called seeds and the ovary wall, which may be fleshy, as in the apple; or dry and hard, as in a maple fruit. The only parts of the fruit, which are genetically representative of both the male and

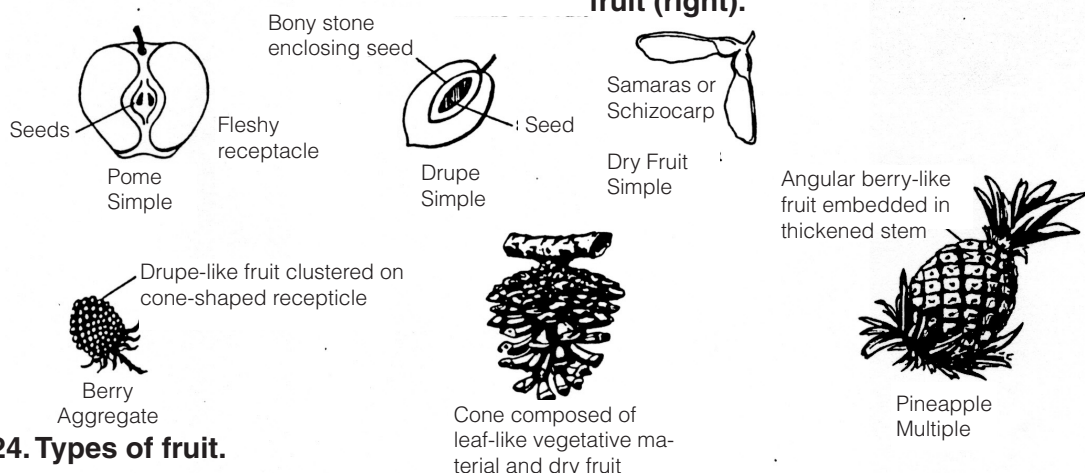

Figure 2.24. Types of fruit.

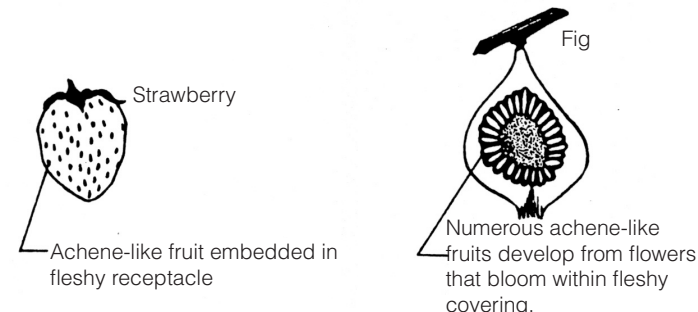

Figure 2.25. Aggregate fruit (left) and multiple fruit (right).

female flowers, are the seeds (mature ovules). The rest of the fruit arises from the maternal plant, therefore genetically identical to the parent. Some fruits have seeds enclosed within the ovary (apples, peaches, oranges, squash, cucumbers). Others have seeds that are situated on the periphery of fruit tissue (corn, strawberry).

Types of fruit

Fruits can be classified as simple fruits, aggregate fruits or multiple fruits. **Simple fruits** are those that develop from a single ovary. These include cherries and peaches (drupe), pears and apples (pome) and tomatoes (berries). Tomatoes are a botanical fruit, since they develop from the flower, as do squash, cucumbers and eggplant. All of these fruits develop from a single ovary. Other types of simple fruit are dry. The fruit wall becomes papery or leathery and hard. Examples are peanut (legumes), poppy (capsule), maple (samara) and walnut (nut).

Aggregate fruits, such as raspberries, come from a single flower that has many ovaries. The flower appears as a simple flower, with one corolla, one calyx and one stem, but with many pistils or ovaries. The ovaries are fertilized separately and independently. If ovules are not pollinated successfully, the fruit will be misshapen and imperfect. Strawberry and blackberry are also aggregate fruits with the addition of an edible, enlarged receptacle. For this reason, they are sometimes termed aggregate-accessory fruits.

Multiple fruits are derived from a tight cluster of separate, independent flowers borne on a single structure. Each flower will have its own calyx and corolla. Examples of multiple fruits are pineapples, figs and beets.

Seed

The seed, or matured ovule, is made up of three parts. The **embryo** is a miniature plant in an arrested state of development. Most seeds contain a built-in food supply called the endosperm (orchid is an exception). The **endosperm** can be made up of proteins, carbohydrates or fats. The third part is the hard outer covering, called a **seed coat**, which protects the seed from disease and insects and prevents water from entering the seed (this would initiate the germination process before the proper time).

Seedlings

Germination is the resumption of active embryo growth. Prior to any visual signs of growth, the seed must absorb water through the seed coat. In addition, the seed must be in the proper environmental conditions. It must be exposed to oxygen, favorable temperatures and for some, correct light. The radicle is the first part of the seedling to emerge from the seed. It will develop into the primary root from which root hairs and lateral roots will develop. The portion of the seedling between the radicle and the first leaf-like structure is called the hypocotyl. The seed leaves, cotyledons, encase the embryo and are usually different in shape from the leaves that the mature plant will produce. Plants producing one cotyledon fall into the group of **monocotyledons or monocots**. Plants producing two seed leaves are called **dicotyledons or dicots**.

Physiology: Plant Growth and Development

The three major plant functions basic for plant growth and development are photosynthesis, respiration and transpiration.

Photosynthesis

One of the major differences between plants and animals is the ability of plants to internally manufacture their own food. To produce food for itself, a plant requires energy from sunlight, carbon dioxide from the air and water from the soil. If any of these ingredients is lacking, photosynthesis or food production will stop. If any factor is removed for a long period of time, the plant will die. Photosynthesis literally means "to put together with light."

Carbon dioxide + Water -----> Sugar + Oxygen

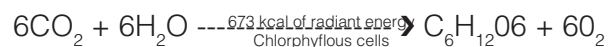

Plants first store the energy from light in simple sugars, such as glucose. This food may be converted back to water and carbon dioxide, releasing the stored energy through the process called respiration. This energy is required for all living processes and growth. Simple sugars are also converted to other sugars and starches (carbo-

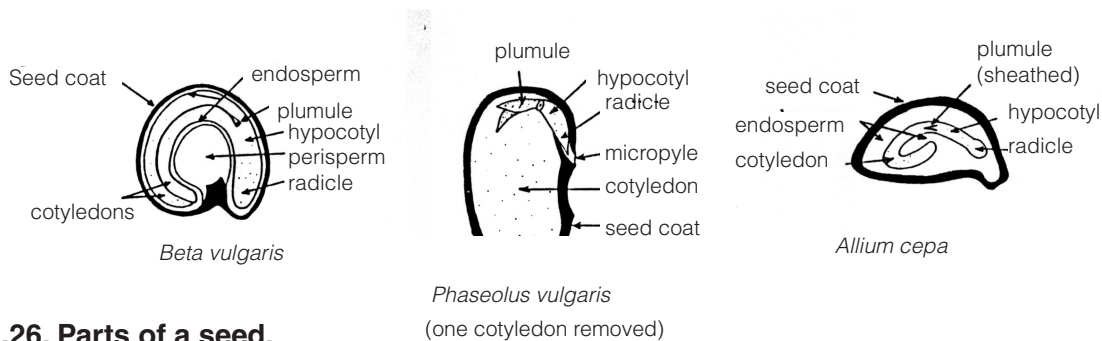

Figure 2.26. Parts of a seed.



Figure 2.27. Germination of dicot (left) and monocot (right)

hydrates), which may be transported to the stems and roots for use or storage or they may be used as building blocks for more complex structures, e.g. oils, pigments, proteins, cell walls, etc.

Any green plant tissue is capable of photosynthesis. Chloroplasts in these cells contain the green pigment, which traps the light energy. However, leaves are generally the site of most food production due to their special structure. The internal tissue (mesophyll) contains cells with abundant chloroplasts in an arrangement that allows easy

movement of water and air. The protective upper and lower epidermis (skin) layers of the leaf include many stomata that regulate movement of the gases involved in photosynthesis into and out of the leaf.

Photosynthesis is dependent on the availability of light. Generally speaking, as sunlight increases in intensity, photosynthesis increases. This results in greater food production. Many garden crops, such as tomatoes, respond best to maximum sunlight. Tomato production is cut drastically as light intensities drop. Only two or three varieties of

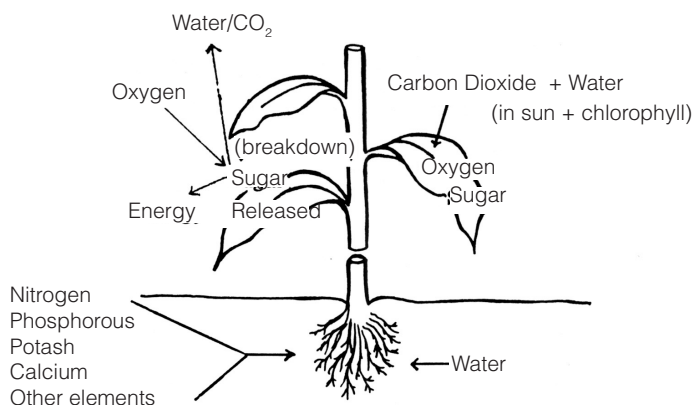

Figure 2.28. How a plant grows.

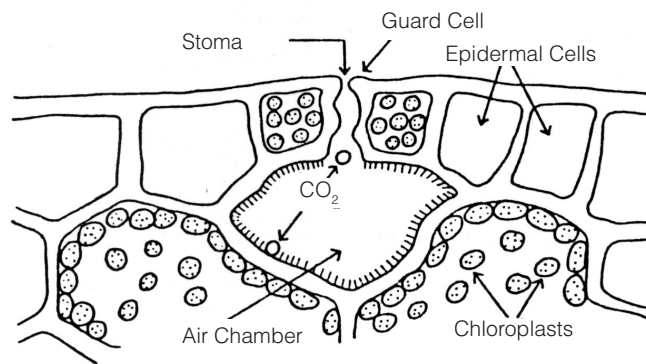

Figure 2.29. Cross-section of a leaf.

“greenhouse” tomatoes will produce any fruit when sunlight is minimal in late fall and early spring.

Water plays an important role in photosynthesis in several ways. First, it maintains a plant's turgor or the firmness or fullness of plant tissue. Turgor pressure in a cell can be compared to air in an inflated balloon. Water pressure or turgor is needed in plant cells to maintain shape and ensure cell growth. Secondly, water is split into hydrogen and oxygen by the energy of the sunlight that has been absorbed by the chlorophyll in the plant leaves. The oxygen is released into the atmosphere and the hydrogen is used in manufacturing carbohydrates. Next, water dissolves minerals from the soil and transports them up from the roots and throughout the plant, where they serve as raw materials in the growth of new plant tissues. The soil surrounding a plant should be moist, not too wet or too dry. Water is pulled through the plant by evaporation of water through the leaves (transpiration).

Photosynthesis also requires carbon dioxide (CO₂), which enters the plant through the stomata. Carbon and oxygen are used in the manufacture of carbohydrates. Carbon dioxide in the air is plentiful enough so it is not a limiting factor in plant growth. However, since carbon dioxide is consumed in making sugars and is not replenished by plants at a rapid rate, a tightly closed greenhouse in midwinter may not let in enough outside air to maintain an adequate carbon dioxide level. With those conditions, improved crops of roses, carnations, tomatoes and certain other crops can be produced if the carbon dioxide level is raised with CO₂ generators or in small greenhouses with dry ice.

Although not a direct component in photosynthesis, temperature is an important factor. Photosynthesis occurs at its highest rate in the temperature range 65 F to 85 F (18 C to 27 C) and decreases when temperatures are above or below this range.

Respiration

Carbohydrates made during photosynthesis are of value to the plant when they are converted into energy. This energy is used in the process of building new tissues (plant growth). The chemical process by which sugars and starches produced by photosynthesis are converted into energy is called respiration. It is similar to the burning of

wood or coal to produce heat (energy). This process in cells is shown most simply as;



This equation is precisely the opposite of that used to illustrate photosynthesis, although more is involved than just reversing the reaction. It is appropriate to relate photosynthesis to a building process, while respiration is a breaking-down process.

Photosynthesis

1. Produces food.
2. Stores energy.
3. Occurs in cells containing chloroplasts.
4. Releases oxygen.
5. Uses water.
6. Uses carbon dioxide.
7. Occurs in sunlight.

Respiration

1. Uses food for plant energy.
2. Releases energy.
3. Occurs in all cells.
4. Uses oxygen.
5. Produces water.
6. Produces carbon dioxide.
7. Occurs in darkness as well as light.

By now, it should be clear that respiration is the reverse of photosynthesis. Unlike photosynthesis, respiration occurs at night as well as during the day. Respiration occurs in all life forms and in all cells. The release of accumulated carbon dioxide and the uptake of oxygen occurs at the cellular level. In animals, blood carries both carbon dioxide and oxygen to and from the atmosphere by means of the lungs or gills. In plants, there is simple diffusion into the open spaces within the leaf, and exchange occurs through the stomata.

Transpiration

Transpiration is the process by which a plant loses water, primarily from leaf stomata. Transpiration is a necessary process involving the use of about 90 percent of the water that enters the plant through the roots. The other 10 percent of the water is used in chemical reactions and in plant tissues. Transpiration is necessary for mineral transport from the soil to the plant parts, for the cooling of plant parts through evaporation, to move sugars and plant chemicals and for the maintenance of turgor pressure. The amount of water lost from the plant depends on several environmental fac-

tors such as temperature, humidity and wind or air movement. An increase in temperature or air movement decreases humidity and causes the guard cells in the leaf to shrink, opening the stomata and increasing the rate of transpiration.

Environmental Factors Affecting Plant Growth

The environment limits plant growth and distribution. If any one environmental factor is less than ideal, it will become a limiting factor in plant growth. Limiting factors are also responsible for the geography of plant distribution. For example, only plants adapted to limited amounts of water can live in deserts. Most plant problems are caused by environmental stress, either directly or indirectly. Therefore, it is important to understand the environmental aspects that affect plant growth. These factors are light, temperature, water, humidity and nutrition.

Light

Light has three principal characteristics that affect plant growth: quantity, quality and duration.

Light **quantity** refers to the intensity or concentration of sunlight and varies with the season of the year. In the northern hemisphere, the maximum is present in the summer and the minimum in winter. The more sunlight a plant receives (up to a point), the better capacity it has to produce plant food through photosynthesis. As the sunlight quantity decreases, the photosynthetic process decreases. Light quantity can be decreased in a garden or greenhouse by using shade cloth above the plants. It can be increased by surrounding plants with white or reflective materials or supplemental lights.

Light **quality** refers to the color or wavelength reaching the plant surface. Sunlight can be broken up by a prism into respective colors of red, orange, yellow, green, blue, indigo and violet. On a rainy day, raindrops act as tiny prisms and break the sunlight into these colors, producing a rainbow. Red and blue light have the greatest effect on plant growth. Green light is least effective to plants as they reflect green. It is this reflected light that makes them appear green to us. Blue light is primarily responsible for vegetative growth or leaf

growth. Red light, when combined with blue light, encourages flowering in plants. Fluorescent, or cool-white, light is high in the blue range of light quality and is used to encourage leafy growth. Such light would be excellent for starting seedlings. Incandescent light is high in the red or orange range, but generally produces too much heat to be a valuable light source. Fluorescent "grow" lights have a mixture of red and blue colors that attempts to imitate sunlight as closely as possible, but they are costly and generally not of any greater value than regular fluorescent lights.

Light **duration**, or photoperiod, refers to the amount of time a plant is exposed to sunlight. When the concept of photoperiod was first recognized, it was thought that the length of periods of light triggered flowering. The various categories of response were named according to the light length (i.e., short-day and long-day). It was then discovered that it is not the length of the light period, but the length of uninterrupted dark periods that is critical to floral development. The ability of many plants to flower is controlled by photoperiod. Plants can be classified into three categories, depending upon their flowering response to the duration of darkness. These are short-day, long-day or day-neutral plants.

Short-day plants form their flowers only when the day length is less than 12 hours in duration. Short-day plants include many spring- and fall-flowering plants such as chrysanthemum and poinsettia.

Long-day plants form flowers only when day lengths exceed 12 hours (short nights). They include almost all of the summer-flowering plants, such as rudbeckia and California poppy, as well as many vegetables including beet, radish, lettuce, spinach and potato.

Day-neutral plants form flowers regardless of day length. Some plants do not really fit into any category but may be responsive to combinations of day lengths. The petunia will flower regardless of day length, but flowers earlier and more profusely under long daylight. Since chrysanthemums flower under the short-day conditions of spring or fall, the method for manipulating the plant into experiencing short days is very simple. If long days are predominant, a shade cloth is used over the chrysanthemum for 12 hours daily to block out light until flower buds are initiated. To bring a long-day plant into flower when sunlight is not present

longer than 12 hours, artificial light is added until flower buds are initiated.

Temperature

Temperature affects the productivity and growth of a plant, depending upon whether the plant variety is a warm- or cool-season crop. If temperatures are high and day length is long, cool-season crops such as spinach will bolt rather than produce the desired flower. Temperatures that are too low for a warm-season crop such as tomato will prevent fruit set. Adverse temperatures also cause stunted growth and poor quality; for example, high temperatures cause the bitterness in lettuce.

Sometimes temperatures are used in connection with day length to manipulate the flowering of plants. Chrysanthemums will flower for a longer period of time if daylight temperatures are 59 F (15 C). The Christmas cactus forms flowers as a result of short days and low temperatures. Temperatures alone also influence flowering. Daffodils are forced to flower by putting the bulbs in cold storage in October at 35 F to 40 F (2 C to 4 C). The cold temperatures allow the bulb to mature. The bulbs are transferred to the greenhouse in midwinter where

growth begins. The flowers are then ready for cutting in three to four weeks.

Thermoperiod refers to daily temperature change. Plants respond and produce maximum growth when exposed to a day temperature that is about 10 to 15 degrees higher than the night temperature. This allows the plant to photosynthesize (build up) and respire (break down) during an optimum daytime temperature and to curtail the rate of respiration during a cooler night. High temperatures cause increased respiration, sometimes above the rate of photosynthesis. This means that the products of photosynthesis are being used more rapidly than they are being produced. For growth to occur, photosynthesis must be greater than respiration.

Low temperatures can result in poor growth. Photosynthesis is slowed down at low temperatures. Since photosynthesis is slowed, growth is slowed, and this results in lower yields. Not all plants grow best in the same temperature range. For example, snapdragons grow best when nighttime temperatures are 55 F (12 C); the poinsettia prefers 62 F (17 C).

Florist cyclamen does well under very cool conditions, while many bedding plants prefer a higher temperature. Recently, it has been found

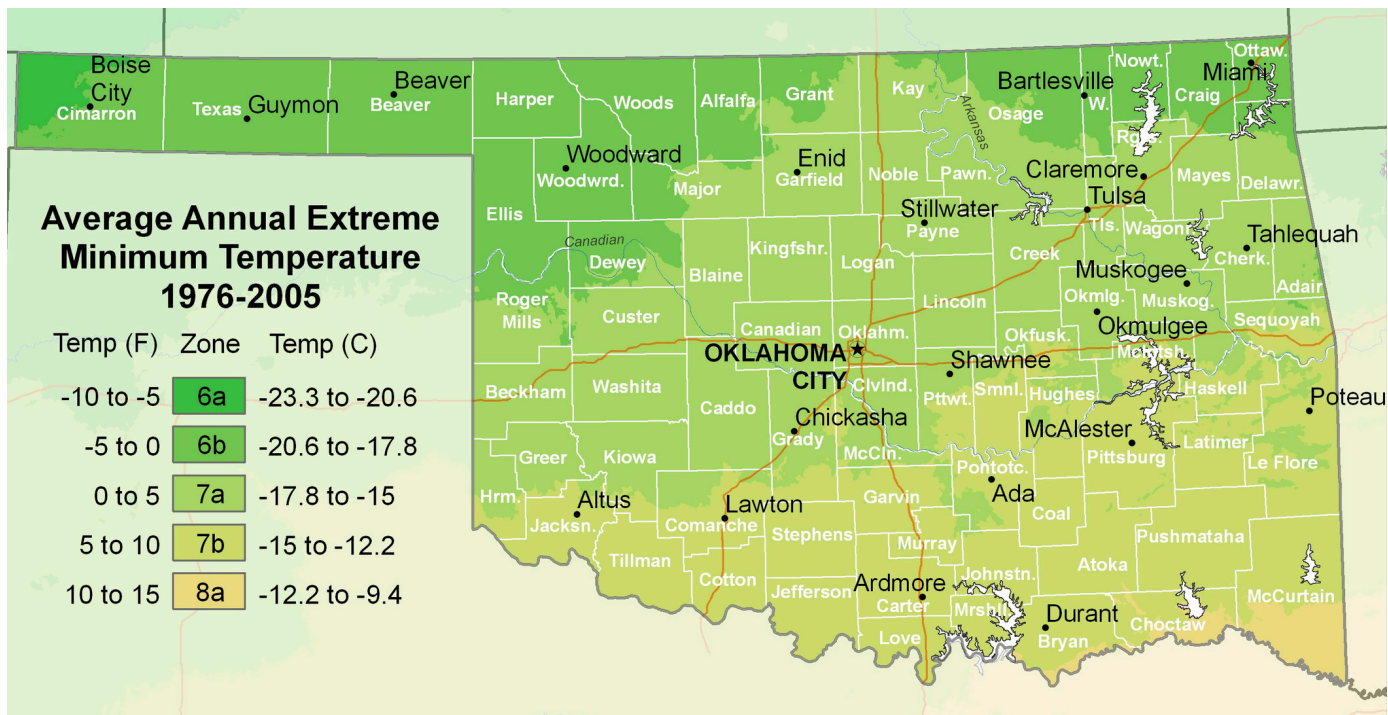

Figure 2.30. USDA Plant Hardiness Zone Map.

that roses can tolerate much lower nighttime temperatures than was previously believed. This has meant a conservation in energy for greenhouse growers.

However, in some cases, a certain number of days of low temperatures are needed by plants to grow properly. This is true of crops growing in cold regions of the country. Peaches are a prime example; most varieties require 700 to 1,000 hours below 45 F (7 C) and above 32 F (0 C) before they break their rest period and begin growth. Lilies need six weeks at 33 F (1 C) before blooming.

Plants can be classified as either hardy or non-hardy, depending upon their ability to withstand cold temperatures. This is the basis of the USDA Plant Hardiness Zone Map (Figure). It should be mentioned that the Hardiness Zone Map does not consider the plant's ability to withstand various soil types (i.e., alkaline versus acidic, clay versus sand).

Winter injury can occur to nonhardy plants if temperatures are too low, or if unseasonably low temperatures occur early in the fall or late in the spring. Winter injury may also occur because of desiccation (drying out) – plants need water during the winter. When the soil is frozen, the movement of water into the plant is severely restricted. On a windy winter day, broadleaved evergreens can become water-deficient in a few minutes; the leaves or needles then turn brown. Wide variations in winter temperatures can cause premature bud break in some plants and consequent bud-freezing damage. Late spring frosts can ruin entire peach crops. If temperatures drop too low during the winter, entire trees of some species are killed by the freezing and splitting of plant cells and tissue.

Review of temperature effects on plant growth:

Photosynthesis:	Increases with temperature to a point.
Respiration:	Rapidly increases with temperature.
Transpiration:	Increases with temperature.
Flowering:	May be partially triggered by temperature.
Sugar storage:	Low temperatures reduce energy use and increase sugar storage.

Dormancy: After a period of low temperature, warmth will break dormancy and the plant will resume active growth.

Water

As mentioned earlier, water is a primary component of photosynthesis. It maintains the turgor pressure or firmness of tissue and transports nutrients throughout the plant. In maintaining turgor pressure, water is the major constituent of the protoplasm of a cell. By means of turgor pressure and other changes in the cell, water regulates the opening and closing of the stomates, thus regulating transpiration. Water also provides the pressure to move a root through the soil. Among water's most critical roles is that of the solvent for minerals moving into the plant and for carbohydrates moving to their site of use or storage. By its gradual evaporation from the surface of the leaf near the stomata, water helps stabilize plant temperature.

Relative humidity (RH) is the ratio of water vapor in the air to the amount of water the air could hold at a given temperature and pressure, expressed as a percent. For example, if a pound of air at 75 F could hold 4 grams of water vapor and there are only 3 grams of water in the air, then the relative humidity is:

$$\text{RH} = \frac{\text{water in the air}}{\text{water the air could hold}}$$

(at constant temperature and pressure)

so, $\text{RH} = 3/4 = .75$ expressed as a % = 75%

Warm air can hold more water vapor than cold air; therefore, if the amount of water in the air stays the same and the temperature increases, the relative humidity decreases.

Water vapor will move from an area of high relative humidity to one of low relative humidity. The greater the difference in humidity, the faster water will move.

The relative humidity in the air space between the cells within the leaf approaches 100 percent; therefore, when the stomate is open, water vapor rushes out. As the vapor moves out, a cloud of high humidity is formed around the stomate. This cloud of humidity helps slow down transpiration and cool the leaf. If air movement blows the humid

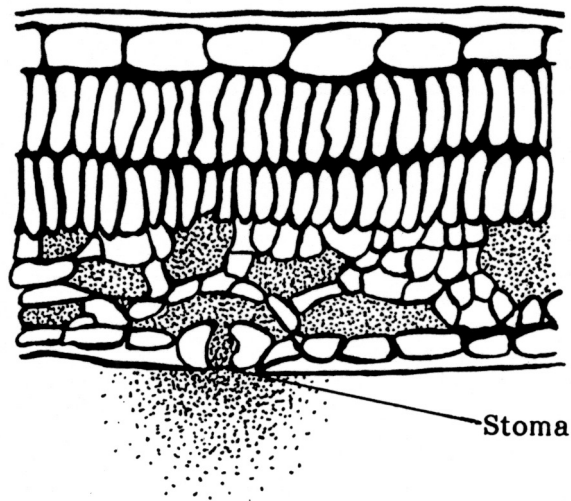

Figure 2.31. Cross-section of a leaf. Dots represent relative humidity.

cloud away, transpiration will increase as the stomata keep opening to balance the humidity.

Movement of water through the plant

The cohesion theory best explains how water moves into and through a plant. It is through this theory that one can begin to understand how water moves from the root system of a California redwood through the vascular system and ultimately to the tips of the leaves some 350 feet above the ground. There are three basic elements of the cohesion theory – the driving force, hydration of the pathway and the cohesion of water.

The driving force for the movement of water through the plant is the tremendous affinity dry air has for water. Discussed earlier in terms of relative humidity, water moves from an area of high water concentration to an area of lower concentration. For example, air at a relative humidity of 50 percent will pull (suck) moisture from plant tissue, which is near 100 percent saturation. This process was discussed earlier and is known as transpiration.

The hydration component refers to water's ability to adhere with great strength to the surface of cell walls. As water is literally sucked through the plant by transpiration, hydration keeps the water moving upward, preventing it from receding back down the plant due to gravity forces.

Cohesion of water is the key component of the theory. Water is highly resistant to changes in volume and can be subjected to strong suction or tension. The driving force of transpiration can pull water from the soil into the roots and up into the

plant. Through the properties of hydration and cohesion, water can be pulled even to the top of a 350-foot redwood tree.

Plant response to lack of water

When plants experience a lack of water in the soil, several responses can occur. The most common sign of drought stress is wilting. However, plants also show other signs, including leaf rolling, color changes, leaf burning and loss of leaves.

Most of the turfgrasses show stress by wilting, as indicated when footprints are seen after a walk across the lawn. Turfgrasses with wider leaves such as St. Augustine will roll their leaves lengthwise in an attempt to reduce the leaf area and water loss. Lawn grasses often show dullness versus the shiny green of a healthy plant.

Many vegetables, flowers and shrubs will show these signs and/or burning of the leaf edges or margins. The crispy margins occur when less than adequate supplies of water are flowing through the plant. Some plants in the landscape and garden will also drop leaves or fruit during drought stress. The plant is simply attempting to lighten the demand for water and increasing its ability to survive drought. Two examples of this plant response follow: 1) ocotillo (*Fouquieria splendens*), a desert plant that drops its leaves when water stressed and 2) the common fig, which drops its fruit at the first sign of water shortage.

Managing plant water stress

The goal of the home gardener is to reduce plant water stress to maintain a quality landscape and/or a productive garden. When adequate moisture is available to the plant, a continuous flow of water exists from the root hairs up to the leaves. If inadequate moisture is present in the soil, or if the rate of evaporation from the leaves exceeds the rate at which water can be moved upwards by the plant, then water stress ensues.

During hot, summer months, most plants on a daily basis can tolerate moderate stress as long as moisture is replenished during the low-stress night period. However, severe or prolonged moisture stress will result in permanent wilting and damage to the plant.

Plants differ greatly in their ability to extract water from the soil and in the amount of water required for normal plant growth and development.

Some plants are classified as drought tolerant because they can function with dry soil conditions. Drought tolerance can be due to several physical features:

- Deep and well-developed root systems.
- Waxy leaf surfaces.
- Leaf hairs, which reduce air flow past the leaf surface.
- Shiny surfaces, which reflect light.
- Leaves that fold up or drop under stress conditions.

Too much water in the rootzone also can be damaging to the plant due to a reduction in oxygen in the area around the root hairs. This can occur when irrigation is performed too frequently or in too great an amount for the plant to remove and use water from the rootzone.

Thus, the objective of a proper irrigation schedule is to supply the right amount of water before harmful stress occurs and enough water to replenish the amount of water used since the last irrigation.

Nutrition

Many people confuse plant nutrition with plant fertilization. Plant nutrition refers to the needs and uses of the basic chemical elements in the plant. Fertilization is the term used when these materials are supplied to the environment around the plant. A lot must happen before a chemical element supplied in a fertilizer can be taken up and used by the plant.

Plants need 16 elements for normal growth. Carbon, hydrogen and oxygen are found in air and water. Nitrogen, potassium, magnesium, calcium, phosphorous and sulfur are found in the soil. The latter six elements are used in relatively large amounts by the plant and are called macronutrients. Other elements are used in much smaller amounts are called micronutrients or trace elements. The micronutrients, also found in the soil, are iron, zinc, molybdenum, manganese, boron, copper, cobalt and chlorine. All elements, both macronutrients and micronutrients, are essential for plant growth.

Most of the nutrients a plant needs are dissolved in water, then absorbed by the roots. Ninety-eight percent of these plant nutrients are absorbed from the soil solution and only about 2 percent are actually extracted from the soil parti-

cles by the root. Most of the nutrient elements are absorbed as charged ions, or pieces of molecules (which are the smallest particle of a substance that can exist and still retain the characteristics of the substance). Ions may be positively charged cations or negatively charged anions. Positive and negative are equally paired, so there is no overall charge. For example, nitrogen may be absorbed as nitrate (NO_3^-), which is an anion with one negative charge. The potassium ion (K^+) is a cation with one positive charge. Potassium nitrate (K^+NO_3^-) would be one nitrate ion and one potassium ion. However, calcium nitrate [$\text{Ca}^{++}(\text{NO}_3^-)_2$] would have two nitrate ions and one calcium ion because the calcium cation has two positive charges.

The balance of ions in the soil is very important. Just as ions having opposite charges attract each other, ions having similar charges compete for chemical interactions and reactions in the environment. Some ions are more active than others or can compete better. For example, both calcium (Ca^{++}) and magnesium (Mg^{++}) are cations with two charges, but magnesium is more active. If both are in competition to be absorbed, the magnesium will be absorbed. This explains why the results of a soil test may indicate that, while there is sufficient calcium in the soil, the plant may still exhibit a calcium deficiency because of an excess of the more active magnesium.

What may be expressed as a deficiency in one micronutrient may really be caused by an excess of another.

For the ions to be easily absorbed, they must first be dissolved in the soil solution. Some combinations of ions, such as potassium nitrate are easily dissolved. When other ions combine, they may precipitate or fall out of solution, thus become unavailable to the plant. Many of the micronutrients form complex combinations with phosphorous and calcium and precipitate out of the soil solution so the nutrients cannot be easily taken up by the plant. The pH, which is a measurement of acidity or alkalinity, greatly affects these chemical reactions. If the soil pH is extremely high (alkaline), many of the micronutrients precipitate out of the solution and are unavailable to the plant. When the soil pH is extremely low (acid), some of the micronutrients become extremely soluble and ion levels may become high enough to injure the plant. The effect of pH varies with the ion, the types of ions in the soil and the type of soil. Therefore, not only is

the amount of the nutrient important, but also the soil pH.

Adequate water and oxygen must be available in the soil. Water is required for nutrient movement into and throughout the roots. Oxygen is required because the mineral ions must be moved into the root cells across their membranes. This is an active absorption process, utilizing energy from respiration. Oxygen is not transported to roots from the shoot. Without adequate oxygen from the soil, there is no energy for nutrient absorption. This also stops active water absorption in which the water flows into the cell due to the higher concentration of nutrients that were actively absorbed.

Anything that lowers or prevents the production of sugars in the leaves can lower nutrient absorption. If the plant is under stress due to low light or extremes in temperature, nutrient deficiency problems may develop. The stage of growth or how actively the plant is growing may also affect the amount of nutrients absorbed. Many plants go into a rest period, or dormancy, during part of the year. During this dormancy, few nutrients are absorbed. Plants may also absorb different nutrients just as flower buds begin to develop.

Nutrients transported from the root to the cell by the vascular system move into the cell through a cell membrane. There are three different ways this happens. First, an entire molecule or ion pair may move through the membrane. If the cell is using energy or active transport to absorb the ions, then only one of the ions in the pair is pulled in the cell. The other will follow to keep the number of positive and negative charges even. Most anions (negative ions) are actively absorbed.

The second way of keeping the charges inside the cell balanced and absorbing a new ion is to exchange one charged ion for another ion with the same charge. A hydrogen ion (H^+) is often released so the cell can absorb another positive ion such as potassium (K^+). Since this is a simple, passive exchange, absorption energy may not be required. Cations may be absorbed by this passive method.

Both of the methods mentioned above may be passive or active. However, the third method, the carrier system, is always active absorption and requires energy. Scientists have discovered that within the cell membrane there are specialized chemicals that act as carriers. The carrier, through chemical changes, attracts an ion from outside the cell membrane and releases it inside the cell. Once

the ion is inside the cell, it is attached to other ions so it does not move out of the cell. Complex chemical reactions are involved in the entire process. Although nutrients can be absorbed passively, research has shown that active absorption must take place if the plant is to grow and be healthy. The factors discussed earlier about absorption by the root are also true for absorption by the cell. A quick review of some of the factors that affect nutrient absorption: type of ion, soil pH, solubility of ion pairs, water, soil oxygen, sugar supply, plant stress and temperature.

Foliar absorption: A special case

Under normal growing conditions, plants absorb most nutrients, except carbon, hydrogen and oxygen from the soil. However, some nutrients can also be absorbed by the leaves if they are sprayed with a dilute solution. The factors that affect absorption by the cell are still important because the nutrient must enter the cell to be used by the plant. Care must be taken that the concentration of the nutrient is not too high, or the leaf will be injured. The leaf is covered by a thin layer of wax called the cuticle that the nutrient must get around or through before it can enter the cell.

Nutrient Outline

Macronutrients

Nitrogen (N)

Absorbed as NO_3^- , NH_4^+ .

Leaches from soil, especially NO_3^- .

Mobile in plant.

Nitrogen excess: Succulent growth, dark green color, weak spindly growth, few fruits, may cause brittle growth, especially under high temperatures.

Nitrogen deficiency: Reduced growth, yellowing (chlorosis), reds and purples may intensify with some plants, reduced lateral breaks. Symptoms appear first on older growth.

Action notes: In general, the best NH_4^+/NO_3^- ratio is 1/1. High NH_4^+ under low sugar conditions (low light) can cause leaf curl. Uptake inhibited by high P levels. N/K ratio extremely important. Indoors, best N/K ratio is 1/1 unless light is extremely high. In soils with high CHO/N ratio, more N should be supplied.

Phosphorous (P)

Absorbed as H_2PO_4^- , HPO_4^- .
Does not leach from soil readily.
Mobile in plant.

Phosphorous excess: Shows up as micronutrient deficiency of Zn, Fe or Co.

Phosphorous deficiency: Reduced growth, color may intensify, browning or purpling in foliage in some plants, thin stems, reduced lateral breaks, loss of lower leaves and reduced flowering.

Action notes: Rapidly “fixed” on soil particles when applied under acidic conditions fixed with Fe, Mg and Al. With alkaline conditions, it is fixed with Ca. Important for young plant and seedling growth. High P interferes with micronutrient absorption and N absorption. Used in relatively small amounts when compared to N and K. May leach from soil high in bark or peat.

Potassium (K)

Absorbed as K^+ , leaches from soil.
Mobile in plant.

Potassium excess: Causes N deficiency in plant and may affect the uptake of other positive ions.

Potassium deficiency: Reduced growth, shortened internodes, marginal burn or scorch (brown leaf edges), necrotic (dead) spots in the leaf, reduction of lateral breaks and tendency to wilt readily.

Action notes: N/K balance is important. High N/low K favors vegetative growth; low N/high K promotes reproductive growth (flower, fruit).

Magnesium (Mg)

Absorbed as Mg^{++} .
Leaches from soil.
Mobile in plant.

Magnesium excess: Interferes with Ca uptake.

Magnesium deficiency: Reduction in growth, marginal chlorosis, interveinal chlorosis (yellow between the veins) in some species. May occur with middle or lower leaves, reduction in seed production, cupped leaves.

Action notes: Mg is commonly deficient in foliage plants because it is leached and not replaced. Epsom salts at a rate of 1 teaspoon per gallon may be used twice a year. Mg can also be absorbed by leaves if sprayed in a weak solution. Dolomitic

limestone can be applied in outdoor situations to rectify a deficiency.

Calcium (Ca)

Absorbed as Ca^{++} , moderately leachable.
Limited mobility in plant.

Calcium excess: Interferes with Mg absorption. High Ca usually causes high pH, which then precipitates many of the micronutrients so they become unavailable to the plant.

Calcium deficiency: Inhibition of bud growth, death of root tips, cupping of maturing leaves, weak growth, blossom end rot of many fruits and pits on root vegetables.

Action notes: Ca is important to pH control and is rarely deficient if the correct pH is maintained. Water stress, too much or too little, can affect Ca relationships within the plant, causing deficiency in the location where Ca was needed at the time of stress.

Sulfur (S)

Absorbed as SO_4^- .
Leachable.
Not mobile.

Sulfur excess: Sulfur excess is usually in the form of air pollution.

Sulfur deficiency: Sulfur is often a carrier or impurity in fertilizers and is rarely deficient. It may also be absorbed from the air and is a byproduct of combustions. Symptoms are a general yellowing of the affected leaves or the entire plant.

Action notes: Sulfur excess is difficult to control.

Micronutrients

The majority of micronutrients are not mobile; thus, deficiency symptoms are usually found on new growth. Their availability in the soil is highly dependent upon the pH and the presence of other ions. The proper balance between the ions present is important, as many micronutrients are antagonistic to each other. This is especially true of the heavy metals where an excess of one element may show up as a deficiency of another. If the pH is maintained at the proper level and a fertilizer that contains micronutrients is used once a year, deficiency symptoms (with the exception of iron deficiency symptoms) are rarely found on indoor plants. Many of the micronutrients are enzyme activators.

Iron (Fe)

Absorbed as Fe^{++} , Fe^{+++} .

Iron deficiency: Interveinal chlorosis primarily on young tissue, which may become white. Fe deficiency may be found with the following conditions even if Fe is in the soil: soil high in Ca, poorly drained soil, soil high in Mn, high pH, high P, soil high in heavy metals (Cu, Zn), oxygen deficient soils or when nematodes attack the roots. Fe should be added in the chelate form; the type of chelate needed depends upon the soil pH.

Iron toxicity: Rare except on flooded soils.

Boron (B)

Absorbed as BO_3^- .

Boron excess: Blackening or death of tissue between veins.

Boron deficiency: Failure to set seed, internal breakdown, death of apical buds.

Zinc (Zn)

Absorbed as Zn^{++} .

Zinc excess: Appears as Fe deficiency. Interferes with Mg.

Zinc deficiency: "Little leaf," reduction in size of leaves, short internodes, distorted or puckered leaf margins and interveinal chlorosis.

Copper (Cu)

Absorbed as Cu^{++} , Cu^+ .

Copper excess: Can occur at low pH. Shows up as Fe deficiency.

Copper deficiency: New growth small, misshapen, wilted. May be found in some peat soils.

Manganese (Mn)

Absorbed as Mn^{++} .

Manganese excess: Reduction in growth, brown spotting on leaves. Shows up as Fe deficiency. Found under acid conditions.

Manganese deficiency: Interveinal chlorosis of leaves followed by brown spots producing a checkered red effect.

Molybdenum (Mo)

Absorbed as MoO_4^- .

Molybdenum deficiency: Interveinal chlorosis on older or midstem leaves, twisted leaves (whiptail).

Chlorine (Cl)

Absorbed as Cl⁻.

Chlorine deficiency: Wilted leaves, which become bronze then chlorotic then die; club roots.

Chlorine toxicity: Salt injury, leaf burn, may increase succulence.

Cobalt (Co)

Absorbed as Co^{++} .

This has been recently established as needed by plants. Essential for nitrogen fixation. Little is known about its deficiency or toxicity symptoms.

Nickel (Ni)

Absorbed as Ni^+ .

This has been recently established as needed by plants. Essential for seed development.

Plant Propagation

Plant propagation is the process of multiplying the numbers of a species, perpetuating a species or maintaining the youthfulness of a plant. There are two types of propagation – sexual and asexual. Sexual reproduction is the union of the pollen and egg, drawing from the genes of two parents to create a new, third individual. Sexual propagation involves the floral parts of a plant. Asexual propagation involves taking a part of one parent plant and causing it to regenerate itself into a new plant. Genetically, it is identical to its one parent. Asexual propagation involves the vegetative parts of a plant: stems, roots or leaves.

The advantages of sexual propagation are:

- 1) it may be cheaper and quicker than other methods;
- 2) it may be the only way to obtain new varieties and hybrid vigor;
- 3) in certain species, it is the only viable method for propagation; and

- 4) it is a way to avoid transmission of certain diseases.

Asexual propagation has these advantages:

- 1) it may be easier and faster in some species;
- 2) it may be the only way to perpetuate some cultivars; and
- 3) it bypasses the juvenile characteristics of certain species.

Sexual propagation

Sexual propagation involves the union of the pollen (male) with the egg (female) to produce a seed. The seed is made up of three parts: the outer seed coat, which protects the seed; the endosperm, which is a food reserve; and the embryo, which is the young plant itself. When a seed is mature and put in a favorable environment, it will germinate or begin active growth. In the following section, seed germination and transplanting of seeds will be discussed.

Seed

To obtain quality plants, start with good quality seed from a reliable dealer. Select varieties to provide the size, color and habit of growth desired. Choose varieties adapted to your area that will reach maturity before an early frost. Many new vegetable and flower varieties are hybrids, which cost a little more than open-pollinated types. However, hybrid plants usually have more vigor, more uniformity and better production than nonhybrids and sometimes have specific disease resistance or other unique cultural characteristics.

Although some seeds will keep for several years if stored properly, it is advisable to purchase only enough seed for the current year's use. Good seed will not contain seed of any other crop, weeds or other debris. Printing on the seed packet usually indicates essential information about the variety, the year for which the seeds were packaged, germination percentage typically expected and notes of any chemical seed treatment. If seeds are obtained well in advance of the actual sowing date or are stored surplus seeds, keep them in a cool, dry place. Laminated foil packets help ensure dry storage. Paper packets are best kept in tightly closed containers and maintained around 40 F in low humidity.

Some gardeners save seed from their own gardens; however, such seed is the result of ran-

dom pollination by insects or other natural agents and may not produce plants typical of the parents. This is especially true of the many hybrid varieties. (See Vegetables chapter for information on saving vegetable seed). Most seed companies take great care in handling seeds properly. Generally, do not expect more than 65 to 80 percent of the seeds to germinate. From those germinating, expect about 60 to 75 percent to produce satisfactory, vigorous, sturdy seedlings.

Germination

There are four environmental factors that affect germination: water, oxygen, light and heat.

Water

The first step in the germination process is the imbibition, or absorption, of water. Even though seeds have great absorbing power due to the nature of the seed coat, the amount of available water in the germination medium affects the uptake of water. An adequate, continuous supply of water is important to ensure germination. Once the germination process has begun, a dry period will cause the death of the embryo.

Light

Light is known to stimulate or to inhibit germination of some seed. The light reaction involved here is a complex process. Some crops, which have a requirement for light to assist seed germination, are ageratum, begonia, browallia, impatiens, lettuce and petunia. Conversely, calendula, centaurea, annual phlox, verbena and vinca will germinate best in the dark. Other plants are not specific at all. Seed catalogs and seed packets often list germination or cultural tips for individual varieties. When sowing light-requiring seed, do as nature does, and leave them on the soil surface. If they are covered at all, cover them lightly with fine peat moss or fine vermiculite. These two materials, if not applied too heavily, will permit some light to reach the seed and will not limit germination. When starting seed in the home, supplemental light can be provided by fluorescent fixtures suspended 6 to 12 inches above the seeds for 16 hours a day.

Oxygen

In all viable seed, respiration takes place. The respiration in dormant seed is low, but some oxygen is required. The respiration rate increas-

es during germination; therefore, the medium in which the seeds are placed should be loose and well aerated. If the oxygen supply during germination is limited or reduced, germination can be severely inhibited.

Temperature

A favorable temperature is another important requirement of germination. It not only affects the germination percentage, but also the rate of germination. Some seeds will germinate through a wide range of temperatures, whereas others require a narrow range. Many seed have minimum, maximum and optimum temperatures at which they germinate. For example, tomato seed has a minimum germination temperature of 50 F and a maximum temperature of 95 F, but an optimum germination temperature of about 80 F. Where germination temperatures are listed, they are usually the optimum temperatures unless otherwise specified. Generally, 65 F to 75 F is best for most plants. This often means the germination flats may have to be placed in special chambers or on radiators, heating cables or heating mats to maintain optimum temperature. The importance of maintaining proper medium temperature to achieve maximum germination percentages cannot be overemphasized.

Germination will begin when certain internal requirements have been met. A seed must have a mature embryo, contain a large enough endosperm to sustain the embryo during germination and contain sufficient hormones or auxins to initiate the process.

Methods of Breaking Dormancy

One of the functions of dormancy is to prevent a seed from germinating before a favorable environment surrounds it. In some trees and shrubs, seed dormancy is difficult to break, even when the environment is ideal. Various treatments are performed on the seed to break dormancy and begin germination.

Seed Scarification

Seed scarification involves breaking, scratching or softening the seed coat so water can enter and begin the germination process. There are several methods of scarifying seeds. In acid scarification, seeds are put in a glass container

and covered with concentrated sulfuric acid. The seeds are gently stirred and allowed to soak from 10 minutes to several hours, depending on the hardness of the seed coat. When the seed coat has become thin, the seeds can be removed, washed and planted. Another scarification method is mechanical. Seeds are filed with a metal file, rubbed with sandpaper or cracked with a hammer to weaken the seed coat. Hot water scarification involves putting the seed into hot water (170 F to 212 F). The seeds are allowed to soak in the water as it cools for 12 to 24 hours and then planted. A fourth method is one of warm, moist scarification. In this case, seeds are stored in nonsterile, warm, damp containers where the seed coat will be broken down by decay over several months.

Seed Stratification

Seeds of some fall-ripening trees and shrubs of the temperate zone will not germinate unless chilled underground as they overwinter. This so-called after-ripening may be accomplished artificially by a practice called stratification.

The following procedure is usually successful. Put sand or vermiculite in a clay pot to about 1 inch from the top. Place the seeds on top of the medium and cover with 1/2 inch of sand or vermiculite. Wet the medium thoroughly and allow excess water to drain through the hole in the pot. Place the pot containing the moist medium and seeds in a plastic bag and seal. Place the bag in a refrigerator. Periodically check to see that the medium is moist, but not wet. Additional water will probably not be necessary. After 10 to 12 weeks, remove the bag from the refrigerator. Take the pot out and set it in a warm place in the house. Water often enough to keep the medium moist. The seedlings should emerge soon. When the young plants are about 3 inches tall, transplant them into pots to grow until time for setting outside.

Another procedure that is usually successful uses sphagnum moss or peat moss. Wet the moss thoroughly, then squeeze out the excess water with your hands. Mix seed with the sphagnum or peat and place in a plastic bag. Seal the bag and put it in a refrigerator. Check periodically. If there is condensation on the inside of the bag, the process will probably be successful. After 10 to 12 weeks remove the bag from the refrigerator. Plant the seeds in pots to germinate and grow. Handle seeds carefully. Often, small roots and shoots are emerging at

the end of the stratification period. Care must be taken not to break these off. Temperatures in the range of 35 F to 45 F (2 C to 7 C) are effective. Most refrigerators operate in this range. Seeds of most fruit and nut trees can be successfully germinated by these procedures. Seeds of peaches should be removed from the hard pit. Care must be taken when cracking the pits. Any injury to the seed itself can be an entry path for disease organisms.

Starting seeds

Media. A wide range of materials can be used to start seeds, from plain vermiculite or mixtures of soilless media to the various amended soil mixes. With experience, you will learn to determine what works best with your conditions. However, keep in mind the good qualities of a germinating medium. It should be rather fine and uniform, yet well aerated and loose. It should be free of insects, disease organisms and weed seeds. It should also be of low total soluble salts and capable of holding and moving moisture by capillary action. One mixture which supplies these factors is a combination of one part each: sterilized soil; sand, vermiculite or perlite; and peat moss.

The importance of using a sterile medium and container cannot be overemphasized. The home gardener can treat a small quantity of soil mixture in an oven. Place the slightly moist soil in a heat-resistant container in an oven set at about 250 F. Use a candy or meat thermometer to ensure that the mix reaches a temperature of 180 F for at least 1/2 hour. Avoid overheating as this can be extremely damaging to the soil. Be aware the heat will release very unpleasant odors in the process of sterilization. This treatment should prevent damping-off and other plant diseases, as well as eliminate potential plant pests. Growing containers and implements should be washed to remove any debris, then rinsed in a solution of one part chlorine bleach to ten parts water.

An artificial, soilless mix also provides the desired qualities of a good germination medium. The basic ingredients of such a mix are sphagnum peat moss and vermiculite, both of which are generally free of diseases, weed seeds and insects. The ingredients are also readily available, easy to handle, lightweight and produce uniform plant growth. "Peat-lite" mixes or similar products are commercially available or can be made at home using this recipe: 4 quarts of shredded sphagnum peat

moss, 4 quarts of fine vermiculite, 1 tablespoon of superphosphate and 2 tablespoons of ground limestone. Mix thoroughly. These mixes have little fertility, so seedlings must be watered with a diluted fertilizer solution soon after they emerge. Do not use garden soil by itself to start seedlings; it is not sterile, is too heavy and will not drain well.

Containers

Flats and trays can be purchased or you can make your own from scrap lumber. A convenient size to handle would be about 12 to 18 inches long and 12 inches wide with a depth of about 2 inches. Leave cracks of about 1/8-inch between the boards in the bottom or drill a series of holes to ensure good drainage.

You can also make your own containers for starting seeds by recycling such things as cottage cheese containers, the bottoms of milk cartons or bleach containers and pie pans, as long as good drainage is provided. At least one company has developed a form for recycling newspaper into pots, and another has developed a method for the consumer to make and use compressed blocks of soil mix instead of pots.

Clay or plastic pots can be used and numerous types of pots and strips made of compressed peat are also on the market. Plant bands and plastic cell packs are also available. Each cell or miniport holds a single plant, which reduces the risk of root injury when transplanting. Peat pellets, peat or fiber-based blocks and expanded foam cubes can also be used for seeding.

Seeding

The proper time for sowing seeds for transplants depends upon when plants may safely be moved outdoors in your area. This period may range from 4 to 12 weeks prior to transplanting, depending upon the speed of germination, the rate of growth and the cultural conditions provided. A common mistake is to sow the seeds too early and then attempt to hold the seedlings back under poor light or improper temperature ranges. This usually results in tall, weak, spindly plants that do not perform well in the garden.

After selecting a container, fill it to within 3/4 inch of the top with moistened growing medium. For very small seeds, at least the top 1/4-inch should be a fine, screened mix or a layer of vermiculite. Firm the medium at the corners and edges

Table 2.2. Seed Requirements.

<i>Plant</i>	<i>Approximate time to seed before last spring frost</i>	<i>Approximate germination time (days)</i>	<i>Germination temperature (degrees F)</i>	<i>Germination in light (L) or dark (D)</i>
Begonia	12 weeks or more	10 to 15	70	L
Browallia		15 to 20	70	L
Geranium		10 to 20	70	L
Larkspur		5 to 10	55	D
Pansy (Viola)		5 to 10	65	D
Vinca		10 to 15	70	D
Dianthus		10 weeks	5 to 10	70
Impatiens	15 to 20		70	L
Petunia	5 to 10		70	L
Portulaca	5 to 10		70	D
Snapdragon	5 to 10		65	L
Stock	10 to 15		70	-
Verbena	15 to 20		65	D
Ageratum	8 weeks	5 to 10	70	L
Alyssum		5 to 10	70	-
Broccoli		5 to 10	70	-
Cabbage		5 to 10	70	-
Cauliflower		5 to 10	70	-
Celosia		5 to 10	70	-
Coleus		5 to 10	65	L
Dahlia		5 to 10	70	-
Eggplant		5 to 10	70	-
Head lettuce		5 to 10	70	L
Nicotiana		10 to 15	70	L
Pepper		5 to 10	80	-
Phlox		5 to 10	65	D
Aster	6 weeks	5 to 10	70	-
Balsam		5 to 10	70	-
Cenburea		5 to 10	65	D
Marigold		5 to 10	70	-
Tomato		5 to 10	80	-
Zinia		5 to 10	70	-
Cucumber	4 weeks or less	5 to 10	85	-
Cosmos		5 to 10	70	-
Muskmelon		5 to 10	85	-
Squash		5 to 10	85	-
Watermelon		5 to 10	85	-

with your fingers or a block of wood to provide a uniform, flat surface.

For medium and large seeds, make furrows 1 to 2 inches apart of 1/8- to 1/4-inch deep across the surface of the container using a narrow board or pot label. By sowing in rows, good light and air movement results and if damping-off fungus does appear, there is less chance of it spreading. Seedlings in rows are easier to label and handle at transplanting time than those which have been sown in a broadcast manner. Sow the seeds thinly and uniformly in the rows by gently tapping the packet of seed as it is moved along the row. Lightly cover the seed with dry vermiculite or sifted medium if they require darkness for germination. A suitable planting depth is usually about twice the diameter of the seed.

Do not plant seeds too deeply. Extremely fine seed such as petunia, begonia and snapdragon are not covered, but lightly pressed into the medium or watered in with a fine mist. If these seeds are broadcast, strive for a uniform stand by sowing half the seeds in one direction, then sowing the other way with the remaining seed in a crossing pattern.

Large seeds are frequently sown into some sort of a small container or cell pack, which eliminates the need for early transplanting. Usually two or three seeds are sown per unit and later thinned to allow the strongest seedling to grow.

Seed tape

Most garden stores and seed catalogs offer indoor and outdoor seed tapes. Seed tape has precisely spaced seeds enclosed in an organic, water-soluble material. When planted, the tape dissolves and the seeds germinate normally. Seed tapes are especially convenient for tiny, hard-to-handle seeds, but are much more expensive. Seed tapes allow uniform emergence, eliminate overcrowding and permit sowing in perfectly straight rows. The tapes can be cut at any point for multiple-row plantings and thinning is rarely necessary.

Pregermination

Another method of starting seeds is pregermination. This method involves sprouting the seeds before they are planted in pots or in the garden. This reduces the time to germination, as the temperature and moisture are easy to control. A high percentage of germination is achieved since en-

vironmental factors are optimum. Lay seeds between the folds of a cotton cloth or on a layer of vermiculite in a shallow pan. Keep moist, in a warm place. When roots begin to show, place the seeds in containers or plant them directly in the garden. While transplanting seedlings, be careful not to break off tender roots. Continued attention to watering is critical.

When planting seeds in a container that will be set out in the garden later, place one seed in a 2- to 3-inch container. Plant the seeds at only half the recommended depth. Gently press a little soil over the sprouted seed and then add about 1/4 inch of milled sphagnum or sand to the soil surface. These materials will keep the surface uniformly moist and are easy for the shoot to push through. Keep in a warm place and care for them as for any other newly transplanted seedlings.

A convenient way to plant small, delicate, pregerminated seeds is to suspend them in a gel. You can make a gel by blending cornstarch with boiling water to a consistency that is thick enough so the seeds will stay suspended. Be sure to cool thoroughly before use. Place the gel with seedlings in a plastic bag with a hole in it. Squeeze the gel through the hole along a premarked garden row. The number of seeds in the gel determines spacing of seeds. If the spacing is too dense, add more gel; if too wide, add more seeds. The gel will keep the germinating seeds moist until they establish themselves in the garden soil.

Watering

After the seed has been sown, moisten the planting mix thoroughly. Use a fine mist or place the containers in a pan or tray, which contains about 1 inch of warm water. Avoid splashing or excessive flooding that might displace small seeds. When the planting mix is saturated, set the container aside to drain. The soil should be moist but not wet.

Ideally, seed flats should remain sufficiently moist during the germination period without having to add water. One way to maintain moisture is to slip the whole flat or pot into a clear plastic bag after the initial watering. The plastic should be at least 1 inch from the soil. Keep the container out of direct sunlight; otherwise the temperature may rise to the point where the seeds will be harmed. Many home gardeners cover their flats with panes of glass instead of using a plastic sleeve. Be sure

to remove the plastic bag or glass cover as soon as the first seedlings appear. Surface watering can then be practiced if care and good judgment are used.

Lack of uniformity, overwatering or drying out are problems related to manual watering. Excellent germination and moisture uniformity can be obtained with a low-pressure misting system. Four seconds of mist every 6 minutes, or 10 seconds every 15 minutes during the daytime in spring seems to be satisfactory. Bottom heat is an asset with a mist system. Subirrigation or watering from below may work well, keeping the flats moist. However, as the flats or pots must sit in water constantly, the soil may absorb too much water and the seeds may rot due to lack of oxygen.

Temperature and light

Several factors for good germination have already been mentioned. The last item, but by no means the least important, is temperature. Since most seeds will germinate best at an optimum temperature that is usually higher than most home night temperatures, special warm areas often must be provided. The use of thermostatically controlled heating cables is an excellent method of providing constant heat.

After germination and seedling establishment, move the flats to a light, airy, cooler location, at a 55 F to 60 F night temperature and a 65 F to 70 F day reading. This will prevent soft, leggy growth and minimize disease troubles. Some crops, of course, may germinate or grow best at a different constant temperature and must be handled separately.

Seedlings must receive bright light after germination. Place them in a south-facing window if possible. If a large, bright window is not available, place the seedlings under a fluorescent light. Use two 40-watt, cool-white fluorescent tubes or special plant growth lamps. Position the plants 6 inches from the tubes and keep the lights on about 16 hours each day. As the seedlings grow, the lights should be raised.

Transplanting and handling

If the plants have not been seeded in individual containers, they must be transplanted to give them proper growing space. One of the most common mistakes made is leaving the seedlings in the seed flat too long. The ideal time to transplant young seedlings is when they are small and there is little

danger from setback. This is usually about the time the first true leaves appear above or between the cotyledon leaves (the cotyledons or seed leaves are the first leaves the seedling produces). Plants should not get hard and stunted or tall and leggy.

Seedling growing mixes and containers can be purchased or prepared similar to those mentioned for germinating seed. The medium should contain more plant nutrients than a germination mix, however. Some commercial soilless mixes have fertilizer already added. When fertilizing, use a soluble houseplant fertilizer, at the dilution recommended by the manufacturer, about every two weeks after the seedlings are established. Remember, too much fertilizer easily damages young seedlings, especially if they are experiencing moisture stress.

To transplant, carefully dig up the small plants with a table knife or wooden plant label. Let the group of seedlings fall apart and pick out individual plants. Gently ease them apart in small groups that will make it easier to separate individual plants. Avoid tearing roots in the process. Handle small seedlings by their leaves, not their delicate stems. Punch a hole in the medium into which the seedling will be planted. Make it deep enough so the seedling can be put at the same depth it was growing in the seed flat. Small plants or slow growers should be placed 1 inch apart and rapid-growing, large seedlings about 2 inches apart. After planting, firm the soil and water gently. Keep newly transplanted seedlings in the shade for a few days or place them under fluorescent lights. Keep them away from direct heat sources and continue watering and fertilizing.

Most plants transplant well and can be started indoor, but a few plants are difficult to transplant. These are generally directly seeded outdoors or sown directly into individual containers indoors. Examples include zinnias and cucurbits, such as melons and squash.

Containers for transplanting

There is a wide variety of containers from which to choose for transplanting seedlings. These containers should be economical, durable and make good use of space. The type selected will depend on the type of plant to be transplanted and individual growing conditions. Standard pots may be used, but they waste a great deal of space and may not dry out rapidly enough for the seedling to have sufficient oxygen for proper development.

There are many types of containers available commercially. Those made out of pressed peat can be purchased in varying sizes. Individual pots or strips of connected pots fit closely together, are inexpensive and can be planted directly in the garden. When setting out plants grown in peat pots, be sure to cover the pot completely. If the top edge of the peat pot extends above the soil level, it may act as a wick, and draw water away from the soil in the pot. To avoid this, tear off the top lip of the pot and the plant flush with the soil level.

Community packs are containers in which there is room to plant several plants. These are generally inexpensive. The main disadvantage of a community pack is that the roots of the individual plants must be broken or cut apart when separating them to put out in the garden.

Compressed peat pellets, when soaked in water, expand to form compact, individual pots. They waste no space, don't fall apart as badly as peat pots, and can be set directly out in the garden. If you wish to avoid transplanting seedlings altogether, compressed peat pellets are excellent for direct sowing.

Community packs and cell packs are strips of connected individual pots. They are available in plastic and frequently used by commercial bedding plant growers, as they withstand frequent handling. In addition, many homeowners find a variety of materials from around the house useful for containers. These homemade containers should be deep enough to provide adequate soil and have plenty of drainage holes in the bottom.

Hardening plants

Hardening is the process of altering the quality of plant growth to withstand the change in environmental conditions which occurs when plants are transferred from a greenhouse or home to the garden. A severe check in growth may occur if plants produced in the home are planted outdoors without a transition period. Hardening is most critical with early crops, when adverse climatic conditions can be expected.

Hardening can be accomplished by gradually lowering temperatures and relative humidity, and reducing water. This procedure results in an accumulation of carbohydrates and a thickening of cell walls. A change from a soft, succulent type of growth to a firmer, harder type is desired.

This process should be started at least two weeks before planting in the garden. If possible, plants should be moved to a 45 F to 50 F temperature indoors or outdoors in a shady location. A coldframe is excellent for this purpose. When put outdoors, plants should be shaded, then gradually moved into sunlight. Each day, gradually increase the length of exposure. Avoid putting tender seedlings outdoors on windy days or when temperatures are below 45 F. Reduce the frequency of watering to slow growth, but don't allow plants to wilt. Even cold-hardy plants will be hurt if exposed to freezing temperatures before they are hardened. After proper hardening, however, they can be planted outdoors and light frosts will not damage them.

The hardening process is intended to slow plant growth. If carried to the extreme of actually stopping plant growth, significant damage can be done to certain crops. For example, cauliflower will make thumb-size heads and fail to develop further. Cucumbers and melons will stop growth.

Propagation of ferns by spores

Though ferns are more easily propagated by other methods, some gardeners like the challenge of raising ferns from spores. One tested method for small quantities follows:

Sterilize a brick by baking it at 250 F for 30 minutes. Cool completely, then put in a pan and add enough water to cover the brick. When the brick is wet throughout, squeeze a thin layer of moist soil and peat (1:1) into the top of the brick. Pack a second layer (about an inch) on top of that. Sprinkle spores on top. Cover with plastic (not touching the spores) and put in a warm place in indirect light. It may take up to a month or more for the spores to germinate. Keep moist at all times. A prothallus (one generation of the fern) will develop first from each spore, forming a light green mat. Mist lightly once a week to maintain high surface moisture; the sperm must be able to swim to the archegonia (female parts). After about three weeks, fertilization should have occurred. Pull the mat apart with tweezers in 1/4-inch squares and space them 1/2 inch apart in a flat containing a 2-inch layer of sand, 1/4-inch layer of charcoal and about 2 inches of soil/peat mix. Cover with plastic and keep moist. When fern fronds appear and become crowded, transplant to small pots. Gradually reduce the humidity until they can survive in the open. Light exposure may be increased at this time.

Asexual Propagation

Asexual propagation, as mentioned earlier, is the best way to maintain some species, particularly an individual best representing that species. Clones are groups of plants that are identical to their one parent and can only be propagated asexually. The Bartlett pear (1770) and the Delicious apple (1870) are two examples of clones that have been asexually propagated for many years.

The major methods of asexual propagation are cuttings, layering, division and budding and grafting. Cuttings involve rooting a severed piece of the parent plant; layering involves rooting a part of the parent and then severing it; and budding and grafting is joining two plant parts from different varieties.

Cuttings

Many types of plants, both woody and herbaceous, are frequently propagated by cuttings. A cutting is a vegetative plant part that is severed from the parent plant to regenerate itself, thereby forming a whole new plant.

Take cuttings with a sharp blade to reduce injury to the parent plant. Sterilize the cutting tool by dipping it in rubbing alcohol or a mixture of one part bleach to nine parts water to prevent transmitting diseases from infected plant parts to healthy ones. Remove flowers and flower buds from cuttings to allow the cutting to use its energy and stored carbohydrates for root and shoot formation rather than fruit and seed production. To hasten rooting, increase the number of roots, or to obtain uniform rooting (except on soft, fleshy stems), use a rooting hormone, preferably one containing a fungicide. To prevent possible contamination of the entire supply of rooting hormone, put some in a separate container for each dipping session.

Insert cuttings into a rooting medium such as coarse sand, vermiculite, soil, water or a mixture of peat and perlite. It is important to choose the

correct rooting medium to get optimum rooting in the shortest time. In general, the rooting medium should be sterile, low in fertility, drain well enough to provide oxygen and retain enough moisture to prevent water stress. Moisten the medium before inserting cuttings, and keep it evenly moist while the cuttings are rooting and forming new shoots.

Place stem and leaf cuttings in bright, indirect light. Root cuttings can be kept in the dark until new shoots appear.

Stem cuttings

Numerous plant species are propagated by stem cuttings. Some can be taken at any time of the year, but stem cuttings of many woody plants must be taken in the fall or in the dormant season.

Tip cuttings

Detach a 2- to 6-inch piece of stem, including the terminal bud. Make the cut just below a node. Remove lower leaves that would touch or be below the medium. Dip the stem in rooting hormone if desired. Gently tap the end of the cutting to remove excess hormone. Insert the cutting deeply enough into the media to support itself. At least one node must be below the surface.

Medial cuttings

Make the first cut just above a node, and the second cut down the stem 2 to 6 inches and just above a node. Prepare and insert the cutting as you would a tip cutting. Be sure to position right side up. Axial buds are always above leaves.

Cane cuttings

Cut cane-like stems into sections containing one or two eyes or nodes. Dust ends with fungicide or activated charcoal. Allow to dry several hours. Lay horizontally with about half of the cutting below the media surface, eye facing upward. Cane cuttings are usually potted when roots and new shoots appear but new shoots from dracaena and croton are often cut off and rerooted in sand.



Figure 2.32. Tip and medial.



Figure 2.33. Cane cutting.

cane

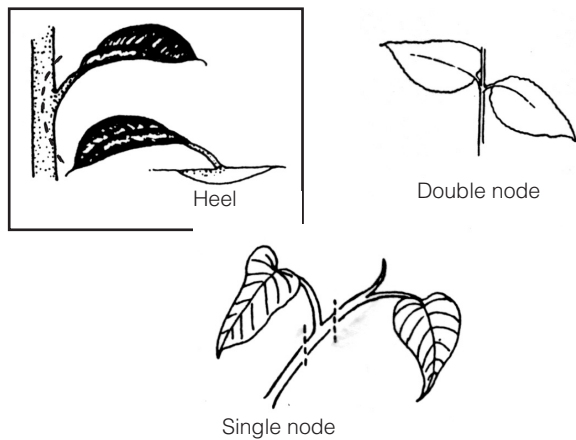

Figure 2.34. Cut areas.

Single node

Single-node cuttings are used for plants with alternate leaves when space or stock material is limited. Cut the stem about ½ inch above and ½ inch below a node. Place cutting horizontally or vertically in the medium.

Double node

This is used for plants with opposite leaves when space or stock material is limited. Cut the stem about ½ inch above and ½ inch below the same node. Insert the cutting vertically in the medium with the node just touching the surface.

Heel cutting

This method uses stock material with woody stems efficiently. Make a shield-shaped cut about halfway through the wood around a leaf and axillary bud. Insert the shield horizontally into the medium.

Leaf cuttings

Leaf cuttings are used almost exclusively for a few indoor plants. Plants such as African violets (*Saintpaulia ionantha*), begonias (*Begonia* spp.), and sansevierias (*Sansevieria trifasciata*)



Whole leaf without petiole



Whole leaf with petiole

Figure 2.35. Leaves with and without petioles.

are choice plants for leaf cuttings. Leaves of most plants will either produce a few roots, but no plant, or just decay.

Whole leaf with petiole

Detach the leaf and up to 1 ½ inches of petiole. Insert the lower end of the petiole into the medium. One or more new plants will form at the base of the petiole. The leaf may be severed from the new plants when they have their own roots, and the petiole reused.

Whole leaf without petiole

This is used for plants with sessile leaves. Insert the cutting vertically into the medium. A new plant will form from the axillary bud. The leaf may be removed when the new plant has its own roots.

Split vein

Detach a leaf from the stock plant. Slit its veins on the lower leaf surface. Lay the cutting, lower side down, on the medium. New plants will form at each cut. If the leaf tends to curl up, hold it in place by covering the margins with the rooting medium.



Split vein

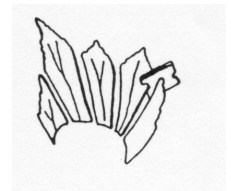

Leaf section

Figure 2.36. Split vein and leaf section.

Leaf sections

This method is frequently used with snake plant and fibrous-rooted begonias. Cut begonia leaves into wedges with at least one vein. Lay leaf flat on the medium. A new plant will arise at the vein. Cut snake plant leaves into 2-inch sections. Consistently make the lower cut slanted and the upper cut straight, so you can tell which is the top. Insert the cutting vertically. Roots will form fairly soon, and eventually a new plant will appear at the base of the cutting. These and other succulent cuttings will rot if kept too moist.

Root cuttings

Root cuttings are usually taken from 2- to 3-year-old plants during their dormant season when they have a large carbohydrate supply. Root cuttings



Plant with large roots

Plants with small roots

Figure 2.37. Root types.

of some species produce new shoots, which then form their own root systems, while root cuttings of other plants develop root systems before producing new shoots.

Plants with large roots: Make a straight top cut. Make a slanted cut 2 to 6 inches below the first cut. Store about three weeks in moist sawdust, peat moss or sand at 40 F. Remove from storage. Insert the cutting vertically with the top approximately level with the surface of the rooting medium. This method is often used outdoors.

Plants with small roots: Take 1- to 2-inch sections of roots. Insert the cuttings horizontally about ½ inch below the medium surface. This method is usually used indoors or in a hotbed.

Layering

Stems still attached to their parent plants may form roots where they touch a rooting medium. Severed from the parent plant, the rooted stem becomes a new plant. This method of vegetative propagation, called layering, promotes a high success rate because it prevents the water stress and carbohydrate shortage that plague cuttings.

Some plants layer themselves naturally, but sometimes plant propagators assist the process. Layering is enhanced by wounding one side of the stem or by bending it very sharply. The rooting medium should always provide aeration and a constant supply of moisture.

Tip layering

Dig a hole 3 to 4 inches deep. Insert the shoot tip and cover it with soil. The tip grows downward first, then bends sharply and grows upward. Roots form at the bend, and the recurved tip becomes a new plant. Remove the tip layer and plant it in the early spring or late fall. Examples: purple and black raspberries, trailing blackberries.

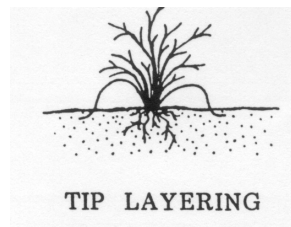

TIP LAYERING

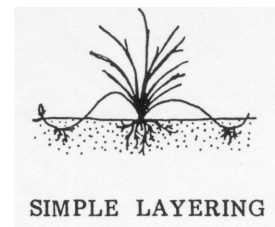

SIMPLE LAYERING



MOUND LAYERING



AIR LAYERING

COMPOUND LAYERING

Figure 2.38. Layering

Simple layering

Bend the stem to the ground. Cover part of it with soil, leaving the last 6 to 12 inches exposed. Bend the tip into a vertical position and stake in place. The sharp bend will often induce rooting, but wounding the lower side of the branch or loosening the bark by twisting the stem may help. Examples: rhododendron and honeysuckle.

Compound layering

This method works for plants with flexible stems. Bend the stem to the rooting medium as for simple layering, but alternately cover and expose stem sections. Wound the lower side of the stem sections to be covered. Examples: heart-leaf philodendron and pothos.

Mound (stool) layering

Cut the plant back to 1 inch above the ground in the dormant season. Mound soil over the emerging shoots in the spring to enhance their rooting. Examples: gooseberries and apple rootstocks.

Air layering

Air layering is used to propagate some indoor plants with thick stems, or to rejuvenate them when they become leggy. Slit the stem just below a node. Pry the slit open with a toothpick. Surround the wound with wet unmilled sphagnum moss. Wrap plastic or foil around the sphagnum moss and tie in place. When roots pervade the moss, cut the plant

off below the root ball. Examples: dumbcane and rubber tree.

The following propagation methods can all be considered types of layering, as the new plants form before they are detached from their parent plants.

Stolons and runners

A stolon is a horizontal, often fleshy stem that can root, then produce new shoots where it touches the medium. A runner is a slender stem that originates in a leaf axil and grows along the ground or downward from a hanging basket, producing a new plant at its tip. Plants that produce stolons or runners are propagated by severing the new plants from their parent stems. Plantlets at the tips of runners may be rooted while still attached to the parent, or detached and placed in a rooting medium. Examples: strawberry and spider plant.

Offsets

Plants with a rosetted stem often reproduce by forming new shoots at their base or in leaf axils. Sever the new shoots from the parent plant after



Figure 2.39. Stolons and runners (left), offsets (right).

they have developed their own root system. Unrooted offsets of some species may be removed and placed in a rooting medium. Some of these must be cut off, while others may be simply lifted off of the parent stem. Examples: date palm, haworthia, bromeliads and many cacti.

Separation

Separation is a term applied to a form of propagation by which plants that produce bulbs or corms multiply.

Bulbs

New bulbs form beside the originally planted bulb. Separate these bulb clumps every three to

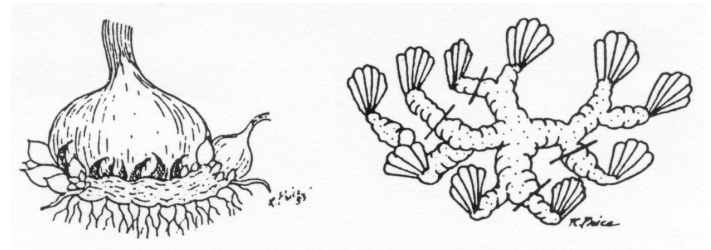

Figure 2.40. Separation of corms (left), division (right).

five years for largest blooms and to increase bulb population. Dig up the clump after the leaves have withered. Gently pull the bulbs apart and replant them immediately so their roots can begin to develop. Small, new bulbs may not flower for two or three years, but large ones should bloom the first year. Examples: tulip and narcissus.

Corms

A large new corm forms on top of the old corm, and tiny cormels form around the large corm. After the leaves wither, dig up the corms and allow them to dry in indirect light for two or three weeks. Remove the cormels, then gently separate the new corm from the old corm. Dust all new corms with a fungicide and store in a cool place until planting time. Examples: crocus and gladiolus.

Division

Plants with more than one rooted crown may be divided and the crowns planted separately. If the stems are not joined, gently pull the plants apart. If horizontal stems unite the crowns, cut the stems and roots with a sharp knife to minimize injury. Divisions of some outdoor plants should be dusted with a fungicide before they are replanted. Examples: snake plant, iris, prayer plant and day lilies.

Grafting

Grafting and budding are methods of asexual plant propagation that join plant parts so they will grow as one plant. These techniques are used to propagate cultivars that will not root well as cuttings or whose own root systems are inadequate. One or more new cultivars can be added to existing fruit and nut trees by grafting or budding.

The portion of the cultivar that is to be propagated is called the scion. It consists of a piece of shoot with dormant buds that will produce the

stem and branches. The rootstock or stock provides the new plant's root system and sometimes the lower part of the stem. The cambium is a layer of cells located between the wood and bark of a stem from which new bark and wood cells originate. (See Fruit chapter for discussion of apple rootstock).

Four conditions must be met for grafting to be successful: the scion and rootstock must be compatible; each must be at the proper physiological stage; the cambial layers of the scion and stock must meet; and the graft union must be kept moist until the wound has healed.

Cleft grafting

Cleft grafting is often used to change the cultivar or top growth of a shoot or a young tree (usually a seedling). It is especially successful if done in the early spring. Collect scion wood 3/8- to 5/8-inch in diameter. Cut the limb or small tree trunk to be reworked, perpendicular to its length. Make a 2-inch vertical cut through the center of the previous cut. Be careful not to tear the bark. Keep this cut wedged apart. Cut the lower end of each scion piece into a wedge. Prepare two scion pieces 3 to 4 inches long. Insert the scions at the outer edges of the cut in the stock. Tilt the top of the scion slightly outward and the bottom slightly inward to be sure the cambial layers of the scion and stock touch. Remove the wedge propping the slit open and cover all cut surfaces with grafting wax.

Bark grafting

Unlike most grafting methods, bark grafting can be used on large limbs, although these are often infected before the wound can completely heal. Collect scion wood 3/8- to 1/2-inch in diameter when the plant is dormant, and store the wood wrapped in moist paper in a plastic bag in the refrigerator. Saw off the limb or trunk of the rootstock at a right angle to itself. In the spring, when the

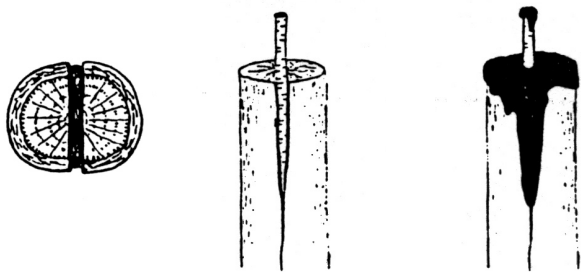

Figure 2.41. Cleft graft.

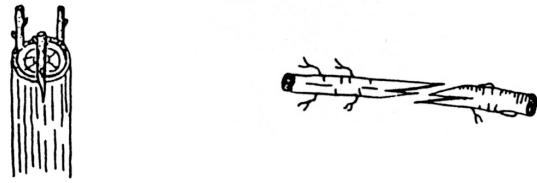

Figure 2.42. Bark graft (left), whip or tongue graft (right).

bark is easy to separate from the wood, make a 1/2-inch diagonal cut on one side of the scion and a 1 1/2-inch diagonal cut on the other side. Leave two buds above the longer cut. Cut through the bark of the stock, a little wider than the scion. Remove the top third of the bark from this cut. Insert the scion with the longer cut against the wood. Nail the graft in place with flat-headed wire nails. Cover all wounds with grafting wax.

Whip or tongue grafting

This method is often used for material 1/4- to 1/2- inch in diameter. The scion and rootstock are usually of the same diameter, but the scion may be narrower than the stock. This strong graft heals quickly and provides excellent cambial contact. Make one 2 1/2-inch long sloping cut at the top of the rootstock and a matching cut on the bottom of the scion. On the cut surface, slice downward into the stock and up into the scion so the pieces will interlock. Fit the pieces together, then tie and wax the union.

Care of the graft

Proper care must be maintained for the following year or two for success in grafting. If a binding material such as strong cord or nursery tape is used on the graft, cut it away shortly after growth starts to prevent girdling. Rubber budding strips have some advantages over other materials. They expand with growth and usually do not need to be cut, as they deteriorate and break after a short time. It is also an excellent idea to inspect the graft after two or three weeks to see if the wax has cracked. If necessary, rewax the exposed areas. After this, the union will probably be strong enough and no more waxing will be necessary.

Limbs of the old variety which are not selected for grafting should be cut back at the time of grafting. The total leaf surface of the old variety should be gradually reduced as the new one increases until at the end of one or two years the new variety

has completely taken over. Completely removing all the limbs of the old variety at the time of grafting increases the shock to the tree and causes excessive suckering. Also, the scions may grow too fast making them susceptible to wind damage.

Budding

Budding or bud grafting is the union of one bud and a small piece of bark from the scion with a rootstock. It is especially useful when scion material is limited. It is also faster and forms a stronger union than grafting.

Patch budding

Plants with thick bark should be patch budded. This is done while the plants are actively growing and the bark slips easily. Remove a rectangular piece of bark from the rootstock. Cover this wound with a bud and matching piece of bark from the scion. If the rootstock's bark is thicker than that of the scion, pare it down to meet the thinner bark, so when the union is wrapped, the patch will be held firmly in place.

Chip budding

This budding method can be used when the bark is not slipping. Slice downward into the rootstock at a 45 degree angle through $\frac{1}{4}$ of the wood. Make a second cut upward from the first cut, about 1 inch. Remove a bud and attending chip of bark and wood from the scion shaped so it fits the rootstock wound. Fit the bud chip to the stock and wrap the union.

T-budding

This is the most commonly used budding technique. When the bark is slipping, make a vertical cut (same axis as the rootstock) through the bark of the rootstock, avoiding any buds on the stock. Make a horizontal cut at the top of the vertical cut (in a T shape) and loosen the bark by twisting the

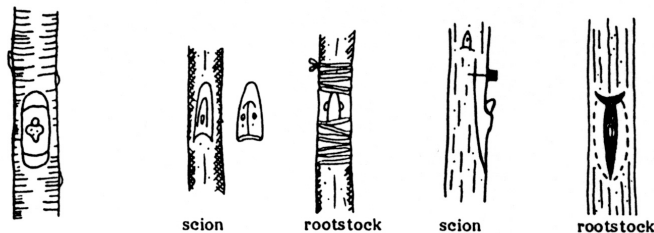

Figure 2.43. Patch bud (left), chip bud (middle) and T-bud (right).

knife at the intersection. Remove a shield-shaped piece of the scion, including a bud, bark and a thin section of wood. Push the shield under the loosened stock bark. Wrap the union, leaving the bud exposed.

Care of Buds

Place the bud in the stock in August. Force the bud to develop the following spring by cutting the stock off 3 to 4 inches above the bud. The new shoot may be tied to the resulting stub to prevent damage from the wind. After the shoot has made a strong union with the stock, cut the stub off close to the budded area.

Plant Tissue Culture

Although technical procedures for aseptic culture of plant cells, tissues and organs are as diverse as the plant material on which they are practiced, a simplified general procedure can be followed in the home. All that is needed are a few basic supplies that can easily be obtained. The procedures outlined in this section can be used in the home to propagate various species of plants, both easy (African violets, coleus, chrysanthemums) and difficult (orchids, ferns, weeping figs) to propagate.

Medium preparation

For 2 pints of tissue culture medium, mix the following ingredients in a 1-quart home canning jar:

- 1/8 cup sugar
- 1 teaspoon all-purpose, soluble fertilizer mixture. Check the label to make sure it has all the major and minor elements, especially ammonium nitrate. If the latter is lacking, add 1/3 teaspoon of a 35-0-0 soluble fertilizer.
- 1 tablet (100 mg) of inositol (myo-inositol), which can be obtained at most health food stores.
- 1/4 of a pulverized vitamin tablet which has 1 to 2 mg of thiamine
- 4 Tablespoons coconut milk (cytokinin source) drained from a fresh coconut. The remainder can be frozen and used later.
- 3 to 4 grains (1/400 teaspoon) of a commercial rooting compound that has 0.1 active ingredient IBA. Fill the jar with distilled or deionized water. If purified water is not available, water

that has been boiled for several minutes can be substituted.

- Shake the mixture and make sure all materials have dissolved.

Baby food jars with lids or other heat-resistant glass receptacles with lids can be used as individual culture jars. They should be half filled with cotton or paper to support the plant material. The medium should be poured into each culture bottle to the point where the support material is just above the solution.

When all bottles contain the medium and have the lids loosely screwed on, they are ready to be sterilized. This can be done by placing them in a pressure cooker and sterilizing them under pressure for 30 minutes or placing them in an oven at 320 F for four hours. After removing them from the sterilizer, place them in clean area and allow the medium to cool. If the bottles will not be used for several days, wrap groups of culture bottles in foil before sterilizing and then sterilize the whole package. Then the bottles can be removed and cooled without removing the foil cover. Sterilized water, tweezers and razor blades, which will be needed later, can be prepared in the same manner.

Plant disinfection and culture

Once the growing medium is sterilized and cooled, plant material can be prepared for culture. Because plants usually harbor bacterial and fungal spores, they must be cleaned (disinfested) before placement on the sterile medium. Otherwise, bacteria and fungi may grow faster than the plants and dominate the culture.

Various plant parts can be cultured, but small, actively growing portions usually result in the most vigorous plantlets. For example, ferns are most readily propagated by using only 1 inch of the tip of a rhizome. For other species, ½ to 1 inch of the shoot tip is sufficient. Remove leaves attached to the tip and discard. Place the plant part into a solution of one part commercial bleach to nine parts water for 8 to 10 minutes. Submerge all plant tissue in the bleach solution. After this time period, rinse off excess bleach by dropping the plant part into sterile water. Remember, once the plant material has been in the bleach, it has been disinfested and should only be touched with sterile tweezers.

After the plant material has been rinsed, remove any bleach-damaged tissue with a sterile razor blade. Then remove the cap of a culture bottle containing sterile medium, place the plant part onto the support material in the bottle, making sure that it is not completely submerged in the medium, and recap quickly.

Transferring should be done as quickly as possible in a clean environment. Therefore, scrub hands and counter tops with soap and water just before beginning to disinfect plant material. Rubbing alcohol or a dilute bleach solution can be used to wipe down the working surface.

After all plants have been cultured, place them in a warm, well lit (no direct sunlight) environment to encourage growth. If contamination of the medium has occurred, it should be obvious within three to four days. Remove and wash contaminated culture bottles as quickly as possible to prevent the spread to uncontaminated cultures.

When plantlets have grown to sufficient size,

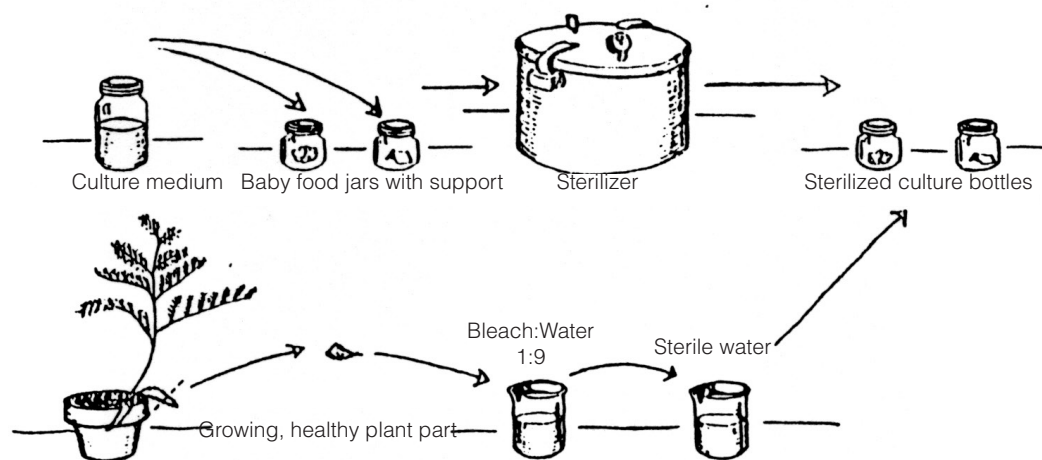

Figure 2.44. Medium preparation.

transplant them into soil. Handle as gently as possible because the plants are leaving a warm, humid environment for a cool, dry one. After transplanting, water the plants thoroughly and place them in a clear plastic bag for several days. Gradually remove the bag to acclimate the plants to their new environment; start with one hour per day and gradually increase time out of the bag during a two-week period, until the plants are strong enough to dispense with the bag altogether.

Plant Science Glossary

Photosynthesis – The manufacture of carbohydrates in green plants from the raw materials carbon dioxide and water.

Xylem – A complex tissue of tough, fibrous, elongated cells forming vessels and woody tissue. Responsible for upward movement of water and minerals from root to leaves.

Phloem – A complex tissue of sieve tubes and parenchyma. Responsible for translocation of food in solution. The inner bark of woody plants.

Monocot – Plant with one cotyledon in its seed.

Dicot – Plant with two cotyledons or seed leaves in its seed.

Stamen – The male part of a flower consisting of anther and filament.

Pistil – The female part of a flower consisting of ovary, ovules, style and stigma.

Perfect Flower – A flower with both stamens and pistils, but not necessarily sepals or petals.

Imperfect Flower – A flower that lacks either stamens or pistils and may or may not have sepals or petals.

Complete Flower – Contains calyx, stamens, pistil and corolla.

Incomplete Flower – Lacks one or more of the four regular complete flower parts.

Calyx – The sepals of a flower as a group.

Corolla – The petals of a flower as a group.

Stomate – Pore in the epidermis of a leaf.

Compound Leaf – A leaf with the blade divided into two or more leaflets.

Leaflet – A single division of a compound leaf.

Simple Leaf – In one piece or unit, not compound.

Pinnate Leaf – Compound leaves with the leaflets arranged on opposite sides along a common axis.

Palmate Leaf – A compound leaf lobed or divided like fingers on a hand.

Bi-pinnate – Leaflets are twice pinnate.

Scarification – Injuring or scratching the seed coat to aid germination.

Stratification – Subjection of seeds to a process like cold temperatures, moisture, etc. to complete the after ripening process and break the rest period.

Evergreen – Retains functional leaves throughout the year.

Deciduous – No living leaves during dormant season.

Annual – Completion of life cycle within one year.

Perennial – Life span of more than two years.

Biennial – Life span of more than one year, but not more than two.

Chapter 3: SOILS AND FERTILIZER

Learning Objectives:

After completing this section, Master Gardener trainees will be able to:

- Define soil and understand its composition and formation.
- Understand physical properties of soil, including texture, structure, porosity, air and water movement, organic matter, soil organisms and groundwater.
- Tell how particular management factors can affect soil physical properties and plant growth.
- Name the essential plant nutrients and tell how they are best managed in a sound soil fertility program.
- Understand soil pH and its management for optimum plant growth.
- Explain the types of nutrient sources, how they are applied and how to calculate quantities needed.
- Understand environmental implications of soil management practices.

Chapter 3: Soils and Fertilizer	54
Soil Properties	54
Soil compositions	54
Soil depth	55
Soil texture	55
Soil structure	56
Internal drainage	56
Soil pH	56
Soluble salt	56
Organic matter	57
Essential Plant Nutrients	75
Macronutrients	57
Secondary nutrients	58
Micronutrients	59
Soil Testing and Fertilizer Application	59
Collecting a representative soil sample	59
Soil pH and BI (buffer index)	61
Plant available N, P and K in the soil	61
General guidelines of fertilization	61
Organic fertilizers	61

Soil Properties

Soil compositions

In the management of soils, it is important to understand what makes up soils and how they are composed. A typical garden soil is made up of about ½ solids and ½ voids. Soil solids are mostly mineral, with only about 1 percent to 2 percent organic matter present. The mineral matter can be further categorized by particle size into sand, silt and clay material. The voids in soil are filled with either air or water. A day or so after irrigation or rainfall, drained soil will have ½ of the voids filled with air and ½ filled with water. A typical soil composition is illustrated in Figure 3.1.

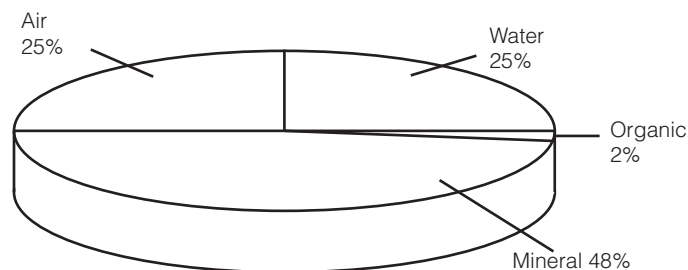

Figure 3.1. Typical air, water, mineral and organic matter distribution in a soil.

The mineral and organic components provide a reservoir of nutrients for plants. The voids, or pores, holding water are usually an adequate supply to maintain the needs of plants for several days. Pores holding air are just as important to plants as those holding water because roots respire, taking in oxygen and giving off carbon dioxide. Large soil pores allow air exchange between the soil and the atmosphere, assuring oxygen for the roots to function normally.

Soil is a dynamic system, which anchors plants and supplies nutrients and water (Figure 3.2). Good soil is key to a beautiful lawn and garden. Chemical analysis of a soil sample determines nutrient status and soil pH. Some of the physical properties can be visually observed. The best way to evaluate soil on-site is to dig into it with a post-hole digger or a shovel. This allows evaluation of depth, layering, color, texture, structure, etc. Several digs are needed to map the range of variation.

Soil depth

Deep soil with good internal drainage is ideal. With the harsh Oklahoma climate, the greater the

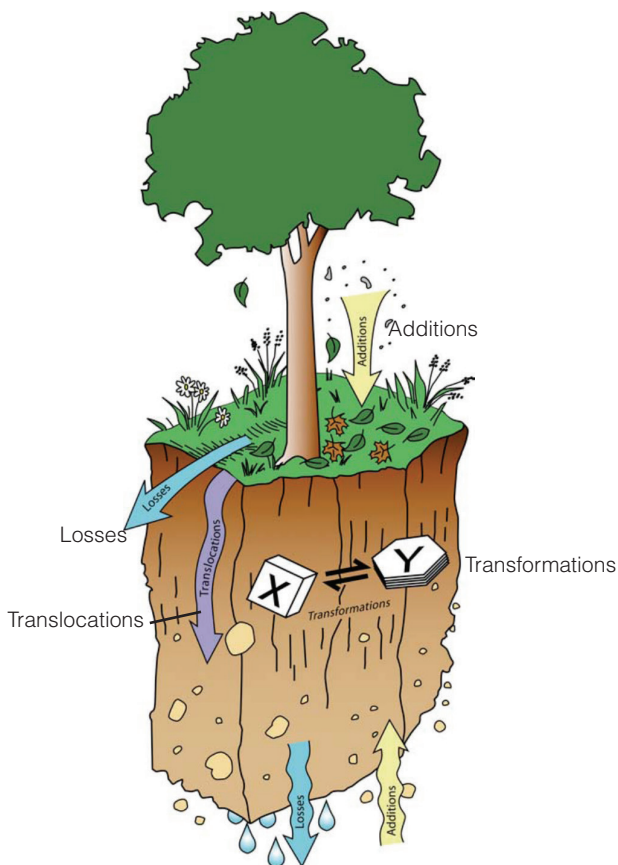

Figure 3.2. Soil is a living body and is capable to support plant growth.

root system, the better the plant can tolerate climatic stress extremes such as heat, drought, wind, and high light intensity. Deep soil also provides a good supply of essential nutrients for better growth. Plants on shallow soil will have problems even with concise drip irrigation and water management. Sudden rainfall periods will force rapid growth at first on shallow soils; however, when the soil becomes saturated, growth stops. Soil depth is best determined by digging straight down with a posthole digger or a shovel. If the soil is easy to dig, it is good for root growth. If the soil is so hard that it cannot be dug, roots will likewise not grow well. Soil 12 inches deep or less will require very concise water and fertilizer management. Deeper soils, 24 inches or more, are more forgiving and allow a greater margin of error in both nutrition and irrigation management.

Soil texture

Soil mineral particles are divided into sand, silt and clay depending on their sizes when completely separated. Sand ranges from 0.05 to 2 mm in size; Clay is smaller than 0.002 mm and silt is in between sand and clay. The relative proportion of the various grain sizes in a soil is called texture. To describe soil texture, names such as sandy loam, clay loam and clay are used. Once a soil has a par-

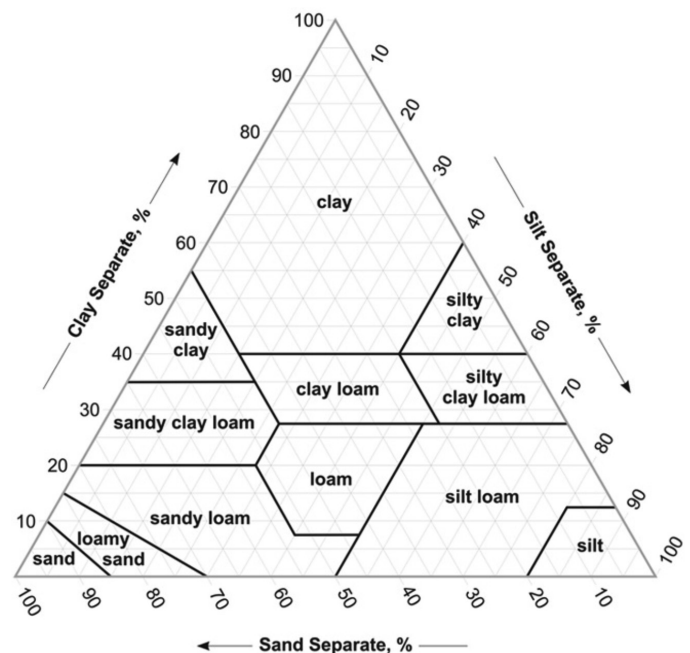

Figure 3.3. Soil texture triangle. Soil texture classes can be found following the percentages of sand, silt and clay for a particular soil.

ticle size analysis, the textural class can be found in the USDA triangle (Figure 3.3). Loams are ideal soils, since they have the right proportions of all size fractions for better structures, water-holding capacity and aeration. The sandy soils drain very fast, but have a very low water- and nutrient-holding capacity. Clays have high water- and nutrient-holding capacity, but drain very slowly. Sometimes, gravel or small rocks (>2mm in diameter) in a soil can improve internal drainage.

Soil structure

Soil structure is the arrangement of its individual particles into small groups, or aggregates. These aggregates may be bound together to form large masses called pads. The pads come in different shapes such as spheres, blocks, columns, and plates (Figure 3.4). Good soil structure can be called soft soil, while poor soil structure or the absence of structure, is termed hard soil. Good soil structure comes from good soil chemistry and adequate organic matter. Clay soils demand good structure; otherwise they are impossible to manage. Good structured soils, such as granular type, have excellent water- and nutrient-holding capacity. Good structure also leads to excellent internal drainage, which allows absorption of water and nutrients. The presence of sodium in soil or water can destroy soil structure, resulting in serious problems from water saturation and poor drainage. To help remedy soils high with sodium content, applications of gypsum are needed, along with heavy leaching with low-sodium water. In addition, com-

paction can also cause poor soil structure problems. For example, heavy tractors and sprayers, constant foot traffic and using the same pattern when mowing will compact the soil, especially when the soil is moist. Repeated compaction will create a hard soil that is very difficult to manage.

Internal drainage

Slow internal soil drainage is a very serious problem. As the soil air content decreases, roots die, active absorption of water across the root membranes stops, salt toxicity increases and hormone production in the root tips stops. Therefore, the rapid movement of water into and out of the root zone is absolutely essential in maintaining good soil air content. To check air movement in a soil, fill a hole with water to determine how well the soil actually drains. If, after one hour of filling a hole, the water level did not change much, the drainage is poor. On the other hand, if the water is completely gone, the soil does not hold water well enough. Adjust the amount and timing of watering to accommodate the soil you have.

Soil pH

Soil pH is a measure of soil acidity or alkalinity. It is expressed on a scale from 0 to 14, with 7 being considered neutral. Below 7 is acidic and above 7 is alkaline. Soil samples need to be collected to determine the pH of the area. The ideal pH for most plants is in the neutral range of 6.5 to 7.5, but many plants do well in the range from 5 to 8 (Figure 3.5). There are many soils in Oklahoma that are very acid and require the addition of lime. A soil sample report will have a lime recommendation, if needed. Alkaline and calcareous soils with a high pH also occur, especially in western Oklahoma. The problems associated with high pH could be iron chlorosis and zinc deficiency. High pH is corrected by adding sulfur rather than lime. Applications of sulfur or sulfuric acid have not proven horticulturally and economically effective, and are not generally recommended for large areas. Foliar application of micronutrients can alleviate iron chlorosis and zinc deficiency symptoms.

Soluble salt

The content of soluble salt in the soil could be another determining factor between success and failure. Soluble salts can come from many different sources. Irrigating with poor quality water and ap-

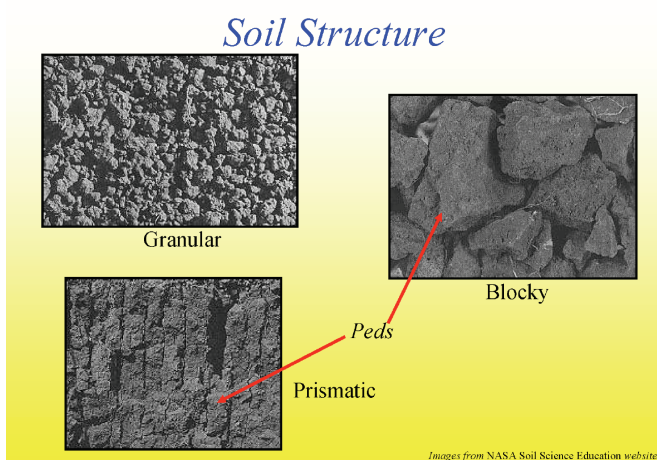

Figure 3.4. Typical structures found in Oklahoma soils. Granular is the best structure for plant growth.

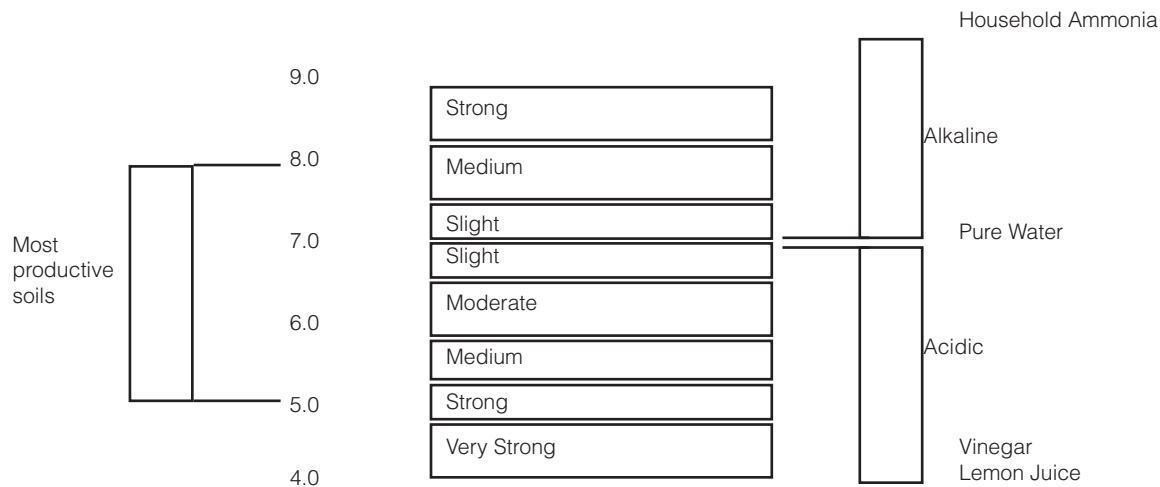

Figure 3.5. Illustration of typical pH ranges commonly found in soils.

plying too much commercial fertilizer or compost are common sources of salt in lawn and gardens. When salts build up in the soil, plants cannot use water efficiently and could die if the salt level is too high. The electrical conductivity (EC) and exchangeable sodium percentage (ESP) are generally provided by a soil salinity test. Soils can be classified into four salt-affected categories, based on their EC and ESP (Figure 3.6). Remediation and management of salt affected soils are discussed in more detail in fact sheet PSS-2226 *Reclaiming Slick-Spots and Salt Affected Soils*.

Organic matter

All organic substances in the soil, living or dead, fresh or decomposed, are part of the soil organic matter. The content of organic matter in

the soil is very important to soil quality because it enhances water- and nutrient-holding capacity and improves soil structure. Therefore, increasing soil organic matter can enhance productivity and environmental quality. Applying compost or animal manure not only supplies needed nutrients, but also adds organic matter to the soil. Another method to increase soil organic matter content is to plant cover crops when possible. Returning all plant residues to the soil and using mulching lawn mowers are highly recommended to preserve nutrients and improve organic matter content. Adding 1 to 2 inches of compost each year goes a long way.

Essential Plant Nutrients

Plants differ in growth habit, morphological features and benefit or purpose they serve the homeowner. However, all plants require 16 chemical elements, as identified by modern science, to survive and reproduce. Most of the essential elements are well supplied in the growing environment and only a few require our management. Based on the amount needed, those nutrients are grouped into macronutrients, secondary nutrients and micronutrients.

Macronutrients

Carbon (C), Hydrogen (H) and Oxygen (O)

Higher plants get their C from carbon dioxide (CO₂) in the atmosphere. There is little we need to do that would benefit plants from increasing the

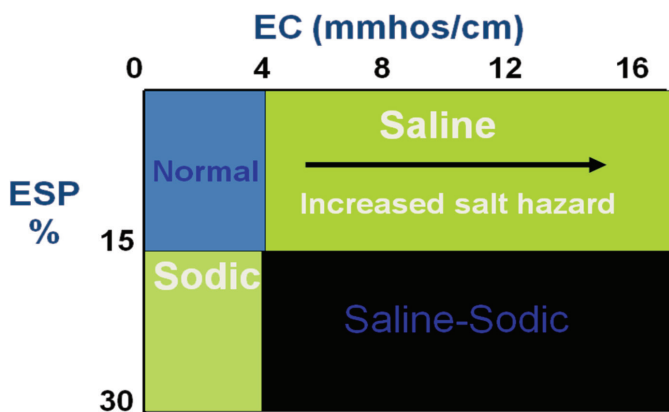

Figure 3.6. Categories of salt affected soils. EC, electrical conductivity; ESP, exchangeable sodium percentage.

C supply. Most of the H and O for plants are supplied by water (H₂O) and air (O₂). As discussed above, timely irrigation and managing the soil to maintain or improve infiltration and internal drainage are important to meeting plant needs for these two elements. In many home landscapes, perennial plants have been wisely selected to thrive in the natural climate and soil of the site. When this is done, little added management is necessary.

Nitrogen (N), Phosphorus (P) and Potassium (K)

Three nutrients, commonly called macronutrients, are required in large amounts by plants. They are nitrogen, phosphorus and potassium. Because these nutrients are primarily supplied from the soil, they are the first elements to become depleted with an intensive cropping system – the result of high produce yields hauled off the fields to market. In response to widespread soil nutrient depletion, the fertilizer industry was born. Subsequently, soils have been replenished with these three nutrients by the addition of mined natural deposits or synthetically prepared soluble forms of fertilizer.

Plant growth and yield are strongly influenced by the supply of N. Of all the nutrients, N is the most commonly deficient, especially when plant vegetation is removed from the area where it grew (e.g., bagging lawn clippings). Because nitrogen is bound organically in amino acids and plant proteins, when plants die, much of the N in the dead tissue remains bound in these organic forms. As plant residue decays and becomes soil organic matter (humus) most N remains organically bound and becomes an important reservoir of slow-release N. Nitrogen in humus cannot be absorbed by plants until it is released by soil microorganisms and is present in inorganic forms as either ammonium (NH₄⁺) or nitrate (NO₃⁻). Clearly, nitrogen management must involve organic matter management. Understanding this is especially important for organic gardeners.

Phosphorus deficiency in mature lawns and gardens is uncommon because plants use only about 1/10 to 1/6 as much phosphorus as they do nitrogen. Also, many homeowners apply as much phosphorus back to the soil in the form of compost and fertilizers as they do nitrogen. Since phosphorus is immobile in the soil, it accumulates and will be adequately supplied by soils with a history of annual inputs of phosphorus. Phosphorus may be

deficient in soil that was previously farmed and received little or no phosphorus input. Phosphorus will most commonly be deficient in recently modified landscapes, such as cut areas where surface soil has been removed, and the P deficient subsoil is being used as a growing medium.

Potassium deficiency is common in high rainfall regions (greater than 35 inches annually) such as eastern Oklahoma. Soils that naturally have a near neutral or higher pH (7 or above) will usually be rich in available potassium (western Oklahoma) because they have developed in arid and semi-arid climates without enough rainfall to leach potassium from the soils.

Secondary nutrients

Calcium (Ca), Magnesium (Mg) and Sulfur (S)

These elements are seldom deficient in the urban landscape. Calcium and magnesium are the main elements responsible for keeping the soil pH from becoming too acidic. Before supplies for plants become deficient, the soil pH is too acidic for plants to grow, and lime must be added to raise the pH back to a suitable level. Because lime is mostly calcium carbonate (some magnesium carbonate), liming to keep the pH desirable also maintains good supplies of calcium and magnesium for plants.

Rainfall in Oklahoma adds about 6 pounds of sulfur per acre per year. While this may not seem like much, plants only require about 1/20 as much sulfur as nitrogen. If sulfur is needed, gypsum (calcium sulfate), ammonium sulfate or elemental sulfur are good sources.

Micronutrients

Molybdenum (Mo), Manganese (Mn)

Copper (Cu)

These elements have not been found to be deficient in Oklahoma soils, and are unlikely to be deficient in landscape plants grown in soil or soil mixes.

Chlorine (Cl) and Boron (B)

Chlorine deficiency is rarely found in Oklahoma. Heavy rainfall will likely leach chloride out of the soil, so it may occur in deep, sandy soils following an unusually wet year. Boron deficiency also occurs in deep sandy soils and has only been reported in peanut production in Oklahoma. It is unlikely homeowners will experience deficiency of

either of these nutrients in their landscapes. However, excessive boron is toxic to plants. A boron test may be warranted, especially if growing grapes.

Iron (Fe) and Zinc (Zn)

Deficiencies of these two nutrients are limited to specific soil-plant conditions or situations. The plants most susceptible to zinc deficiency in Oklahoma are pecans. Commercial growers routinely apply foliar zinc fertilizers to avoid the problem. Deficiency shows up as rosetting, a shortening of internodes (space along stem between nodes or leaves). This causes the leaves or branches of new growth to appear as if they are all growing out of the same point on the main stalk. Corn is the second most susceptible plant to zinc deficiency. Most soils in Oklahoma are adequately supplied with Zn, but it may show deficiency symptoms when soil pH is greater than 7.5, since Zn is unavailable in high pH soils.

Most soils contain a large quantity of iron. However, most of this iron is in an oxide form, like rust, that plants are unable to use directly. Iron deficiency in plants is limited to high pH soils (central and western Oklahoma) and in plants that do not have an effective mechanism for extracting iron from soil (more acid-loving plants). These plants are unable to acidify soil next to their roots or chelating Fe to improve its availability. Pin oaks are an example of plants that do poorly in neutral and high pH soils, and are not recommended for parts of central and western Oklahoma for that reason. Most garden plants are effective in obtaining adequate iron from soils, making iron deficiency uncommon.

When iron deficiency does occur, it will appear as interveinal chlorosis (yellowing between the veins) in the newest leaves, since iron is not translocated well from old leaves to new leaves, as are N, P and K. Deficiencies can be corrected by a foliar application of a 1 percent solution of iron sulfate, iron-ammonium sulfate (ferrous or ferric ammonium sulfate) or other fertilizers containing Fe. However, if the supply of iron from the soil to the plant is not improved, chlorosis will again develop on new growth because iron is not translocated from old, well-fed tissue to new, deficient tissue. Soil organic matter helps to naturally chelate iron and improve its availability to plants. Improving and maintaining high organic matter levels in the soil usually reduces or eliminates the problem. Also, periodic surface application of elemental sulfur will make the

soil acidic and reduce the chance of iron chlorosis if the soil has a high pH.

Soil Testing and Fertilizer Application

When and how often to soil test

Soil testing should be viewed with the same approach as one would take toward servicing the lawn mower or car engine. If we do not know how much gas and oil are present, we check the fuel gauge and dip stick. If we want to know whether or not soil pH, available phosphorus and available potassium exist at desirable levels we need to test the soil. Since these soil properties do not change much from one year to the next, it is not necessary to soil test the same area each year. However, a soil test once every three years will provide information needed to manage a lawn and garden properly.

Plant-available nitrogen in the soil changes considerably from year to year and even within a season. Plant growth, addition of nitrogen fertilizer and decay of organic matter will all cause significant changes in available nitrogen in just a few days. It is not necessary to soil test each year or within the season to closely monitor nitrogen needs. Instead, add small amounts of nitrogen fertilizer throughout the growing season, or aerate the soil by shallow cultivation to promote the release of organic nitrogen to improve plant growth or green color.

Collecting a representative soil sample

Homeowners and lawn care professionals must realize the spatial variability existing around the yard when collecting a soil sample. Each sample collected should represent the area to be fertilized. The fertility level in the vegetable garden may be different from that of a flower bed. Soil test parameters in the front yard may be drastically different from those in the backyard. Therefore, separated samples may need to be collected from those areas so they can be treated differently. Avoid sampling "odd-ball" areas. A core or slice from the surface to a depth of 6 inches should be taken from 15 to 20 locations in each area and composited into one representative sample for testing (Figures 3.7 and 3.8).

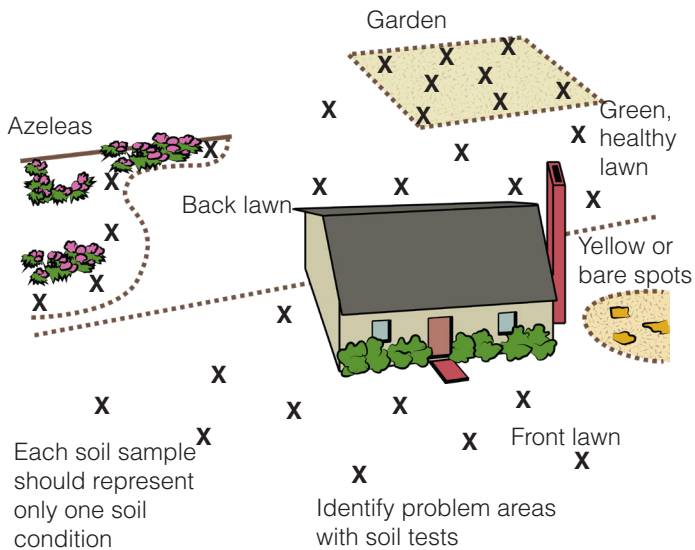

Figure 3.7. Taking soil samples separately to accurately represent pH and soil fertility levels of the vegetable garden, flower bed and lawns.

Soil samples may be submitted to the county Extension office. They will send the samples to the Soil, Water and Forage Analytical Laboratory for testing, then send the results back to you with fertilizer recommendations. Soil samples are analyzed routinely for pH, nitrate nitrogen, plant available phosphorus and potassium, while secondary and micronutrients are tested on request. A num-



Figure 3.8. Key points of taking a good soil sample (right tool, consistent depth and enough subsamples).

ber of other tests, such as soil organic matter content and texture, are also available through the lab.

Soil test interpretations

Figure 3.9 is a soil test report from the OSU soil testing lab. It shows the test results on the upper part of the report and a brief interpretation on the lower part of the report. The amount of lime and nu-

Routine Test		Secondary Nutrients	Micronutrients
pH;	5.6	SO4-S (lbs/A)	Fe (ppm):
Buffer Index:	6.8	Surface:	Zn (ppm):
NO3-N (lbs/A):		Subsoil:	B (ppm):
Surface:	2	Ca (lbs/A):	Cu (ppm):
Subsoil:		Mg (lbs/A):	
Soil Test P Index:	15 (8 ppm)	Additional Tests	
Soil Test K Index:	116 (58 ppm)		

Interpretation and Requirements for: Garden (No yield goal needed for N recommendation)

Test	Interpretation	Requirement	Recommendation and Comments
pH	Lime Needed	55 lbs ECCE/1,000 sq. ft.	
Nitrogen	Deficient	1 lb/1,000 sq. ft. N	
Phosphorus	Deficient	2.5 lbs/1,000 sq. ft. P ₂ O ₅ annually	
Potassium	Deficient	2.7 lbs/1,000 sq. ft. K ₂ O annually	

Figure 3.9. An example of soil test report shows soil pH, amount of nitrate nitrogen and plant available phosphorus and potassium in the soil. The amount of lime needed to bring pH to 6.5, and the amount of nitrogen, phosphorus and potassium needed are shown in the lower part.

trients are recommended based on the crop given, soil pH and soil plant available nutrient levels.

Soil pH and BI (buffer index)

When soil pH is less than 5.9, lime is recommended for lawn and gardens. The amount of lime needed to bring soil pH to 6.5 is based on the buffer index. For this example, the buffer index is 6.8, so 55 pounds per 1,000 square feet is 100 percent ECCE (effective calcium carbonate equivalent). This number is on the bag indicating the purity and fineness of the lime. For gardens, lime should be applied and incorporated by cultivation. This may be done as a part of regularly scheduled cultivation to incorporate plant residue. If the soil is from a lawn area, aerating the lawn after application will help incorporate the lime. Bermuda grass lawns with a soil pH less than 5.0 will benefit from lime even if it cannot be incorporated. Irrigation and rainfall will help move the lime down into the thatch layer. Through time, the lime will move into cracks and worm channels, bringing it in contact with and neutralizing acidic soil near plant roots. Once the liming is complete, it may take a few months before the pH changes. However, it should not be necessary to lime again for several years.

Some plants, such as blueberries and azaleas, require low soil pH. Other plants, such as fescue, can grow well at reasonably low pH. Therefore, lime may not be needed even if the soil test report makes a recommendation. Recommendations specific to the site, fertilization times, schedules, application or other special conditions may be listed by the county educator in addition to the lab results shown.

Plant available N, P and K in the soil

Nitrate Nitrogen ($\text{NO}_3\text{-N}$) is water soluble and readily available for plant uptake. This test shows the amount of $\text{NO}_3\text{-N}$ present in the soil and it will be subtracted from the amount of N needed. The N recommended is the amount needed per application. Several applications may be needed during the whole growing season.

Phosphorus (P): This method determines phosphorus availability index in the soil. A level of 65 is desired for all crops, which is considered 100 percent sufficient. A soil test with 40 percent sufficiency means 40 percent of plant phosphorus needs will be supplied by the soil. The remainder must be provided by adding fertilizer. If no phos-

phorus is added, the yield will only be 40 percent of the potential yield.

Potassium (K): Like phosphorus, potassium soil tests estimate K availability in the soil and the test indicates a certain percent sufficiency. The optimum level will vary with crop, soil type and other soil related factors, but 300 is considered adequate for lawn and gardens.

Table 3.1 shows the general classification of N, P and K levels in the soil. Additional nutrients need to be applied if a soil test indicates the levels are medium or lower. There is no need to apply more nutrients when they are high. It may be harmful to your plants and the environment if nutrient levels are excessive.

General guidelines of fertilization

A soil test estimates the ability of soil to provide nutrients to plants. This analysis takes some of the guesswork out of fertilization. The key for a useful soil test is to provide the lab with a good soil sample. Nitrogen is not stable in the soil, so it needs to be applied in small amounts, but multiple times. A good starting point for any crop is at the beginning of the growing season. Add 40 pounds nitrogen per acre or about 1 pound per 1,000 square feet (because one acre is 43,560 square feet). However, P and K only need to be applied once per year, typically at the beginning of the season and based on soil test levels. Table 3.2 is the N, P and K recommendations for lawn and garden soils.

Synthetic fertilizers

Most homeowners may only buy fertilizers formulated for the lawn and garden from nurseries or department stores. There are many different brands and fertilizer formulations available for

Table 3.1. General Classification of Certain Nutrients on the Soil Test Report.

	$\text{NO}_3\text{-N}$ lbs/acre	<i>P</i> Test Index	<i>K</i> Test Index
Very Low	<5	<10	<75
Low	5-25	10-20	75-150
Medium	25-50	20-65	150-300
High	50-100	65-120	300-500
Excessive	>100	>120	>500

Table 3.2. Recommendations Nitrogen, Phosphorus and Potassium in Lawns and Gardens.

Soil Test N (lbs/acre)	N (lbs/1000sq. ft)	Soil Test P	P ₂ O ₅ (lbs/1000sq. ft)	Soil Test K	K ₂ O (lbs/1000sq. ft)
0-15	1.0	0-20	2.5	0-100	6.0
15-30	0.7	20-40	2.0	100-200	3.0
30-45	0.3	40-65	1.0	200-300	1.0
>45	0	>65	0	>300	0

purchase. The fertilizer analysis, such as 10-20-10 (Figure 3.9), given on the package refers to the percentage of weight. All fertilizers are labeled with three numbers, giving the percentage by weight of nitrogen (N), phosphate (P₂O₅) and potash (K₂O), respectively. For simplicity, those numbers are said to represent N, P and K. It is actually not N-P-K, but N- P₂O₅- K₂O. However, there is no need to be concerned about this as the amount of P and K recommended in Table 3.2 are also in P₂O₅ and K₂O. No conversions are needed.

Besides the premixed fertilizers, there are other common bulk fertilizers, such as ammonium nitrate (34-0-0), urea (46-0-0), diammonium phosphate (18-46-0) and muriate of potash (0-0-60), available at agricultural retail outlets. Those bulk fertilizers are typically less expensive than small bagged fertilizers.

If a soil test is showing low in P and K as well as N, use a complete fertilizer, such as 13-13-13 for a year or two, then retest the soil. If the test is already high in P and K, apply fertilizers containing N only

or ones with low P and K, such as: 46-0-0 (urea) or 29-3-4. This will avoid overapplying certain nutrients, which can negatively affect plant growth.

So, how much fertilizer must be added to get the predetermined amount of nitrogen? The answer to this problem depends upon the fertilizer being used, since commercial materials containing only nitrogen will range from 46 percent (urea) to 21 percent (ammonium sulfate). Once it is decided on how much nitrogen to add, the amount of fertilizer required to get that much nitrogen is calculated by dividing the nitrogen amount by the percent N in the fertilizer and multiplying the answer by 100. For example, if we need 1 pound of N per 1,000 square feet from ammonium nitrate fertilizer (34 percent N), the amount of fertilizer needed is

$$1 \text{ pound N} / 34 \times 100 = \underline{2.94 \text{ pounds}} \text{ ammonium nitrate fertilizer}$$

If the lawn is 10,000 square feet, then you need:

$$2.94 \times 10,000 \div 1,000 = 29.4 \text{ pounds of ammonium nitrate}$$

This is the amount per application. It may need to be applied several times during the growing season, depending on the desired look and required maintenance. Try to avoid applying N too late in the season. The disadvantage of having high levels of available N in the soil late in the fall is that it will stimulate growth of annual winter weeds like henbit. To avoid this, it is best not to fertilize after the first of September and allow the lawn and garden plants to deplete the soil of available nitrogen. The exception would be for fall and winter plantings, like a fescue lawn. Too much nitrogen late in the season may also promote disease, such as



Figure 3.9. Fertilizer bags with different nutrient analyses.

spring dead spot, and reduced winter hardiness of perennial plants.

For the example shown in Figure 3.9, N, P and K are all needed, so 13-13-13 or a similar complete fertilizer would be used at the rate of about 1 pound of N per application (which is $1/13 \times 100 = 7.7$ pounds of 13-13-13 per 1,000 square feet). Every application will add about one pound of P_2O_5 and K_2O also. The needs of P and K will be met after about three applications. Nitrogen only fertilizer is used for the rest of the season.

Just as it will take many years of small phosphate additions to raise the soil to adequate levels, it will take many years of crop removal to lower the soil test from high values to values below 65, signaling the need to add phosphate. Soils with already high levels of P will be able to supply plants with adequate phosphate for many years without fertilizer or compost additions.

Organic fertilizers

Organic fertilizers or organic soil amendments are products derived from the remains or by-prod-

ucts of a once-living organism. Some organic products have a nutrient guarantee, such as blood meal and bone meal, but others are sold as soil amendments with no nutrient guarantee, even though they have nutrient values. Table 3.3 lists common organic sources of nutrients available in most areas.

In general, organic fertilizers release nutrients slowly and gradually because organic fertilizers depend on soil organisms to break them down to release nutrients. An organic amendment may only release 50 percent of the total N during the first growing season. In contrast, N in commercial synthetic fertilizers is readily available. Therefore, a doubled amount of total N from an organic source needs to be applied to supply the needed N.

Organic fertilizers not only supply all the nutrients for plant growth, but also provide valuable organic matter to build soil quality. However, the nutrient ratios of most organic fertilizers are fixed. For example, the N to P ratio in poultry litter is 1-to-1, but the N and P required by plants is about 4-to-1. If using poultry litter or compost to meet the N needs, too much P is applied. The unneeded P will build up in the soil, resulting in P runoff to surface water, causing water quality deterioration. The other drawback of using large quantities of organic amendments is the accumulation of soluble salts in the soil, which can negatively affect plant growth. One strategy of properly using organic fertilizer is to apply a moderate amount, supplemented with a N-rich organic source or synthetic N fertilizers.

All the plant materials from the yard are good sources of organic matter. They should be recycled. Bagging clippings not only removes nutrients from the lawn, but also increases the volume of residential solid waste. Other organic yard wastes, such as pruning material and dead and dying plants should be finely chopped and incorporated into the soil or added to a compost pile.

Table 3.3. Common organic source of nutrients and their nutrient contents.

Source	Total N (%)	P_2O_5 (%)	K_2O (%)
Feedlot Manure	1	1	1
Poultry Litter	3	3	2.5
Alfalfa Meal	2.5	0.5	2
Blood Meal	12		
Fish Meal	9	6	
Bone Meal		10	
Wood Ash			5

Chapter 4

VEGETABLE GARDENING

Learning Objectives:

After completing this section, Master Gardener trainees will be able to:

- Know the characteristics of a good vegetable garden site.
- Understand soil fertility and its importance for garden success.
- Be familiar with major vegetable family groups.
- Know the difference between cool- and warm-season vegetables.
- Understand the benefits of using mulch in the vegetable garden.
- Understand different types of fertilizer for the vegetable garden.
- Be familiar with methods of pest control for vegetable gardens.
- Differentiate between insect and disease symptoms on vegetables.

Chapter 4: Vegetable Gardening.....64

Assessing the Garden Site.....	64
Soil Fertility: Basis for Gardening.....	65
Comparing Organic and Commercial Fertilizers.....	67
Composting.....	69
Guidelines.....	70
Tips.....	70
Soil Fertility Summary.....	71
Crops and Garden Layout.....	72
Alternatives to Traditional Gardening.....	73
Intensive Gardening Methods.....	74
Components of intensive gardens.....	74
Container Gardening.....	78
Gardening Tips.....	80
Things to avoid.....	81
Additional tips.....	81
Soil Tillage.....	81
Selecting Gardening Equipment.....	82
Seed for the Garden.....	83
Transplants for the Garden.....	87
Summer Care.....	90
Watering.....	92
Weed Control.....	93
Mulching Garden Soils.....	93
Mulching materials.....	94
Fall Gardening.....	95
Fall garden summary.....	96
Extending the Growing Season.....	97
Season extending summary.....	101
Diagnosis of Abiotic (Non-Disease)	
Vegetable Problems.....	102
Nutrient deficiency disorders.....	102
Physical Disorders.....	103
Disease and Nematode Control.....	108

Plant disease management tools.....	108
Controlling nematodes.....	109
Fungicides.....	109
Crop rotation.....	110
Sanitation.....	110
Insect Control.....	111
Organic Gardening Basics.....	112
Soil—the basics of organic gardening.....	113
Herbs.....	117
Production Hints for Popular Home Garden Vegetables.....	119
Harvest Hints.....	124

Assessing Your Garden Site

Choosing the Site

The selection and preparation of the garden site is an important key to growing a home garden successfully. Gardens have traditionally been located in areas separate from other parts of the landscape because they were considered unsightly. However, with proper planning, the garden can be both functional and attractive. Landscape designs today often incorporate edible plants into areas of the landscape and ornamental plants such as flowering annuals in the vegetable garden. This approach can offer gardening opportunities nearly year round.

Ideal sites: Location is important. Gardens located near the home allow keeping up on dai-

ly maintenance and harvesting at the right time to maximize production and quality. An area exposed to full or near full sunlight with deep, well-drained, fertile soil is ideal. For summer gardens in hot locations, full sun in the morning and mid-afternoon shade is desirable. The site should be located near a water supply and away from trees and shrubs that would compete with the garden for light, water and nutrients. Slope, as well as air movement, should also be considered. Any adjustments that could lessen a potential problem should be considered. While these conditions are ideal, many gardeners may have small or otherwise less optimal areas to grow vegetables. It is still possible to grow a vegetable garden by modifying certain cultural practices and types of crops grown.

Light exposure: A garden site should be carefully considered regarding exposure to sun. The garden should receive a minimum of six hours of direct sunlight each day, although eight to 10 hours per day is more ideal. Areas with partial shade can be used, like under young trees; under mature trees with high lacy canopies; or in bright, airy places which receive only one to two hours of direct sun per day. Several vegetables will grow with these conditions including beans, beets, broccoli, cabbage, cauliflower, chard, kohlrabi, leaf lettuce, peas, potatoes, radishes, rhubarb, spinach and turnips. Unfortunately, no vegetables will grow well under full, dense shade.

Wind protection and slope: Seedlings can be damaged by excessive winds, but too little wind will promote slow drying of wet foliage and encourage plant disease problems. In reality, a balance of some air movement with protection from excessive winds is ideal. Homeowners should consider fences, barriers, landscape plantings (wind rows), covers, etc. to protect plants. Communication with neighbors can do wonders in protecting the garden from pesticide drift. Advise them of any intended spraying, and ask they notify you. Slope is another factor to consider when locating the garden. A slope exceeding 10 percent can result in excessive runoff and erosion, therefore terracing or other means for soil conservation will be needed. Like wind, a balance is needed (1 to 2 percent slope) to promote adequate drainage for surface water. Adequate slope will also allow for dissipation of cold air from the site, providing some frost protection. Cold air settles downhill just like water.

Soil: Many soils can be used for gardening, but all should drain well, be fertile and easy to till. If necessary, soils can be modified to make them more ideal. Soil texture refers to the relative amounts of sand, silt and clay in the soil. Sand is the largest particle size, clay the smallest and silt is in between. Particle size confers different physical and chemical characteristics, advantages and disadvantages. Varying amounts of each combine to constitute different soil types. Most soils are a mixture of the three types of soil particles, with sandy loams being some of the more productive types for vegetable gardens.

Soil Fertility: Basis for Gardening

Ideal soil: The ideal soil for a vegetable garden is deep, friable (easily crumbled), well drained and rich in organic matter. Proper soil preparation provides the basis for seeds to germinate and plants to grow well. Check the fertility and pH of the soil by having it analyzed at least once every three to five years. A soil test will also indicate the current nutrient levels of the soil. Samples submitted through the county Extension office to the OSU Soil, Water and Forage Analytical testing lab can provide specific vegetable crop recommendations through their on-line system.

Sandy soils: These soils are easy to work, drain well and roots penetrate them very easily. For these reasons, they make good garden soils, but gardeners should recognize these soils dry out quickly, leach nutrients readily and are highly erodible. Because of this, irrigation and fertilization schedules should be adjusted or split accordingly. Water and nutrient retention can be improved by adding organic matter to sandy soils.

Clay soils: These soils are common in Oklahoma. They are usually fertile and do not leach. However, these soils present drainage problems, are difficult to work and provide a poor rooting media for seedling plants. Drainage and aeration can be improved by adding organic matter to clay soils.

Loam soils: From the standpoint of plant growth, medium-textured soils such as loams are the most ideal. Loamy soils provide free movement of air and water, have good water retention, are usually fertile and offer little resistance.

Organic matter: Gardeners can improve soil structure, water and nutrient retention and permeability by adding organic matter to soils. Incorporate or topdress with a 2- to 3-inch layer of well-rotted leaves, compost, aged manure or peat moss in the spring before preparing the soil and again in the fall after harvest. Green manure crops such as annual rye, ryegrass and wheat can be planted on the garden site in the fall and left to rot in place or plowed under in the spring prior to planting. Be cautious of potential herbicide residues in manure, hay and straw used for organic matter. Ask your supplier for details.

Lack of topsoil: Topsoil depth for gardening should be a minimum of 10 inches for good plant growth. Many areas, especially around new construction sites, lack topsoil or had only 1 to 2 inches added for lawn establishment. Additional topsoil may need to be added to make garden sites workable. When adding topsoil, make certain it is the desired type of soil (some type of loam). Also, make sure it doesn't contain potential problems such as herbicide carryover, nematodes or other problem-causing substances. Plant success is greatly influenced by soil depth. If the site is not well drained or if the soil is thin, the use of raised beds can help alleviate this problem.

pH is critical: Soil pH measures the degree of acidity or alkalinity of the soil. The pH scale ranges from zero to 14 with 7 being neutral. Below 7 is considered acidic and above 7 is considered alkaline. This scale is logarithmic; meaning a whole number change on the scale is a tenfold change. For example, a pH of 6 is ten times more alkaline than 5, and 7 is 100 times more alkaline than 5. The pH is critical because it affects the availability of 13 of the 16 essential plant nutrients needed for plants to grow and flourish. Although the requirements for vegetables may vary, most garden crops thrive at a soil pH of 6.0 to 7.5. If the pH is too high or too low, the crop will suffer.

pH requirements for garden vegetables: Vegetables in the slightly tolerant pH group can be grown successfully on soils that are on the alkaline side of neutral. These plants do well up to pH 7.6 if there is no essential nutrient deficiency. Calcium, phosphorus and magnesium are nutrients most likely to be deficient in soils more acidic than pH 6.

Nitrogen-Phosphorus-Potassium: There are 16 essential plant nutrients that are needed by

Table 4.1. Tolerance of vegetable crops to soil acidity and pH ranges for optimal growth*

<i>Slightly tolerant</i> (pH 6.8 to 6.0)	<i>Moderately tolerant</i> (pH 6.8 to 5.5)	<i>Very tolerant</i> (pH 6.8 to 5.0)
Asparagus	Bean	Chicory
Beet	Bean, lima	Dandelion
Broccoli	Brussels sprouts	Endive
Cabbage	Carrot	Fennel
Cauliflower	Collard	Potato
Celery	Corn	Rhubarb
Chard, Swiss	Cucumber	Shallot
Cress	Eggplant	Sorrel
Chinese cabbage	Garlic	Sweet potato
Leek	Gherkin	Watermelon
Lettuce	Horseradish	
Muskmelon	Kale	
New Zealand spinach	Kohlrabi	
Okra	Mustard	
Onion	Parsley	
Orach	Pea	
Parsnip	Pepper	
Salsify	Pumpkin	
Soybean	Radish	
Spinach	Rutabaga	
Watercress	Squash	
	Tomato	
	Turnip	

*Source: *Knott's Handbook for Vegetable Growers*, 4th edition.

all plants to thrive and produce. Of these 16, only three normally need to be added to the soil in relatively high amounts for use by plants. These three include nitrogen (N), phosphorus (P₂O₅), and potassium (K₂O). To use an analogy, phosphorus and potassium are like the oil and coolant in your car's engine while nitrogen is like the fuel. Once phosphorus and potassium levels are adequate in a soil, keep an eye on them and add them only when recommended by a soil test. On the other hand, nitrogen is very water soluble, easily leached and is generally needed, sometimes several times per season to ensure a productive garden. Nitrogen is absorbed by plants in two forms: nitrate and ammonium. Some commercial fertilizers contain both nitrate and ammonium forms of nitrogen (ammonium nitrate 34-0-0), some contain ammonia forms

only (aqua ammonia 20-0-0) and urea (urea 46-0-0). Organic fertilizers go through nitrification to become available for plants to use. The nitrification process takes some time, particularly during cold weather, so there can be a delay in a garden's response to non-nitrate nitrogen fertilizers.

Soil sampling: During the winter, before beginning a garden, get a sample of the garden soil tested to determine the pH and nutrient content. Fact sheet PSS-2207 *How to Get a Good Soil Sample* is a great reference on how to do it correctly. The soil test will tell how much lime or sulfur and fertilizer to initially add to the garden. Once balanced, it is easier to maintain a proper level of fertility year after year. When lime is recommended, apply it several months before planting. Fall applications of lime will have time to correct soil acidity problems before spring planting. See Chapter 3 for more information about collecting soil samples. Soil sample supplies are available from your local county Extension office. Your county Extension educator will send the sample to the Soil, Water and Forage Analytical laboratory at OSU for testing. Once complete, recommendations from the county Extension educator will be made on the amounts of fertilizer to use on your garden area. Private companies also test soil and give detailed reports, but may be more expensive. Choose a soil testing lab and stick with it to avoid confusion. Comparison of results from different labs is like comparing apples to oranges, as labs may vary in their equipment, methods and standards. For best results, follow the instructions for soil testing carefully.

Advantages & disadvantages to adding organic matter to the soil

- Make a heavy soil lighter, more crumbly and friable. This is especially important in areas where the soil is high in clay.
- Hold light soil particles together and help anchor them against erosion. This increases the water-holding capacity of soil in sandy areas.
- Provide some of the nitrogen needed by plants.
- Release nutrients already in soil by turning them into soluble compounds that can be absorbed by the roots of the plants.
- Permit growth and functioning of micro-organisms.
- Furnish a small quantity of all elements essential for plant growth.
- The addition of organic matter to the soil does not reduce infestation of weeds, directly dimin-

ish plant diseases or protect crops from insect attacks. Nor does it have any marked influence on the vitamin content of crops grown in the soil.

- Organic matter in the form of fresh manure, straw, wood shavings or sawdust must decompose. This organic matter may tie up nitrogen and can result in crop nitrogen deficiencies while microorganisms are decomposing. Always add composted manures and materials, or add additional nitrogen to counteract binding and speed up decomposition.

Comparing Organic and Commercial Fertilizers

Nutrients available in both types: The nutrients in commercial fertilizers provide the same nutrients found in organic fertilizers, but in most commercial fertilizers, nutrients are more readily available to the plant than in organic fertilizers. Organic fertilizers and other non-nitrate fertilizers contain nutrients in the organic form, in particular nitrogen. It must be converted through the nitrification process to the inorganic form by soil microorganisms (mostly bacteria) before these forms can be used by the plant. Some organic sources supply organic matter in addition to nutrients, which is beneficial to all garden soils.

What commercial fertilizers can and won't do

Where recommended and properly applied, commercial fertilizers don't injure the soil or poison vegetables, other plant growth, animal life, earthworms or bacteria in the soil. On the contrary, the addition of fertilizer provides microbial, plant and animal life in the soil with essential nutrients.

What organic fertilizers can and won't do

Prices for comparable quantities of nutrients are generally higher for organic compared to inorganic sources. The nutrients from organic sources like manure become available to plants as the material decomposes. Nutrients from organic material are not as readily available to plants as those from inorganic sources; however, this has the advantage of providing available nutrients over a longer period of time. Conversely, the supply of a particular nutrient at a given time may be inadequate, leading to a possible nutrient deficiency. When or-

Table 4.2. N, P and K content of some commercial fertilizers.*

Material	N (%)	P ₂ O ₅ (%)	K ₂ O (%)
Ammonium nitrate	34	0	0
Ammonium phosphate-sulfate	16	20	0
Ammonium sulfate	21	0	0
Anhydrous ammonia	82	0	0
Calcium nitrate	15.5	0	0
Urea	46	0	0
Phosphoric acid	0	52	0
Single superphosphate	0	18	0
Triple superphosphate	0	46	0
Potassium chloride	0	0	60
Potassium nitrate	13	0	44

*Percentages from *Knott's Handbook for Vegetable Growers*, fourth edition.

organic fertilizers are applied, deficiencies are most likely to occur in the early season during relatively cool periods when microorganism activity is decreased and young plants have not developed an extensive root system. Microorganisms carry out the decomposition process of organic materials. When applying organic material in any form, soil test regularly.

From Table 4.3, it can be determined that 100 pounds of poultry manure would provide 4.5 pounds of N, 1.5 pounds of P₂O₅, and 1.5 pounds of K₂O. This compares with 100 pounds of 10-20-10 commercial fertilizer providing: 10 pounds of N, 20 pounds of P₂O₅ and 10 pounds of K₂O.

The addition of organic matter will add some nutrients to the soil. You may need to add commercial fertilizer as well. Many commercial fertilizers are simply rock or mineral materials rich in nutrients. Take caution to not overdo it with any source of fertilizer, whether commercial or organic in form.

Wood ashes for vegetable gardens

Wood ashes contain some beneficial potassium (K₂O), but are very alkaline and can raise the pH of the soil (Fact sheet PSS-2238, *Fireplace Ashes for Lawn and Garden*). They are beneficial in soils that are too acidic or deficient in K₂O. Ashes should not be applied to soils with a neutral or alkaline pH, or soils already high in K₂O. Overapplication can raise the pH levels, resulting in disease

Table 4.3. N, P and K content of organic materials.

Material	N (%)	P ₂ O ₅ (%)	K ₂ O (%)
Blood meal	15	1.3	0.7
Cottonseed meal	5-10	1.3	1.2
Grass clippings	1.0	0	2.0
Bone meal	2-4	20-25	0.2
Rock phosphate	0	25-30	0
Wood ashes	0	1-2	3-7
Fish emulsion	3-6	0	0
Sheep manure ^a	2.5	1.5	1.5
Poultry manure ^a	4.5	3.2	1.3
Horse manure ^b	0.7	0.25	0.55
Cow manure ^b	0.6	0.15	0.45

^a Commercial pulverized,

^b Fresh

development on some vegetables, and nutrient deficiencies in others. Potatoes grown in alkaline soils can develop a disease called scab. Wood ashes have a high soluble salt content, and sodium is much higher in certain wood species, such as oak. The amount of wood ashes that can be applied safely varies with different soil types. The maximum amount to spread on light sandy soils is 10 gallons per 1,000 square feet. Up to 20 gallons per 1,000 square feet can be applied to heavier, clay based soils. One application should be adequate for several seasons, therefore test the soil yearly when applying wood ash. Excessive applications can harm the soil and require additional soil amendments to restore productivity.

Applying fertilizers

It is important fertilizers are used at correct rates and applied in the proper manner. Don't assume if a little is good, a lot is better. This can lead to major problems in the garden. Stick with the recommended rates in the soil test results. Most gardeners are working with areas much smaller than an acre, therefore your personal soil test results should be described in pounds per 1,000 square feet. See Chapter 3 for more information regarding calculating fertilizer rates.

Pre-plant Fertilizing: Fertilizer should generally be applied before, at or immediately after planting time. The fertilizer can be broadcast, applied in the row or applied around the base of the plant. A com-

bination of these methods can also be used. Fertilizer is broadcast by spreading it on top of the soil with a broadcast or drop type fertilizer spreader in an east-west and north-south direction (to provide a uniform application). Fertilizer should be incorporated with irrigation, or tilled 3 to 4 inches deep after application. Generally, one-half to two-thirds of the recommended nitrogen fertilizer, along with the recommended phosphorus and potassium is broadcast over the entire garden immediately prior to planting or transplanting. The remaining nitrogen fertilizer can be added at a later date. This application can be topdressed or applied in furrows 3 inches to the sides of the row or plant and slightly below the level of the seed. This method is known as banding.

Post-plant Fertilizing: To keep garden vegetables productive, extra nitrogen fertilizer should be applied to the soil by sidedressing or topdressing. This will ensure a supply of nitrogen as the plant grows and develops. It is also beneficial in sandy soils or in seasons of abundant rainfall, as nitrogen is often leached out of the root zone area. Avoid getting fertilizer on the plant foliage. Ammonium sulfate (21-0-0-24) and urea (46-0-0) or organic forms of nitrogen may be used as a side dressing for vegetables. If practicing modified no-till in the garden, simply apply the recommended fertilizer beside or near the plant. To sidedress, make a small trench with a hoe or garden plow 4 to 6 inches from the plant on both sides of the row and about 1 to 2 inches deep. Uniformly scatter the fertilizer in the trench, cover with soil, then water. The fertilizer material may also be broadcast near the row and incorporated with overhead irrigation.

Sidedress at the right time: Generally, about one half of the nitrogen requirement for the crop should be applied with sidedress applications. Sidedress sweet corn when it is about 12 inches high; potatoes three weeks after emergence and again at tuber formation; and tomatoes after the first fruit cluster has set. In the case of more than one sidedressing (i.e. potato), split the remaining nitrogen required in half, therefore applying ½ pre-plant, ¼ at emergence and ¼ at tuber formation. Crops such as tomatoes, eggplant and pepper require two or three sidedressings per season because of their long growth cycles.

Sidedressing cucurbits: Cucurbits should be sidedressed at vining (vining is when the plant stops growing vertically and begins growing horizontally at a rapid rate). Individual plants or hills can be sidedressed with 1½ teaspoons of urea (46-0-0) per plant. For widely spaced plants (such as cucumbers or cantaloupe), the sidedressing fertilizer can be banded 6 inches from the plant base. Vegetable plants should be sidedressed about midway through their maturity cycle except when grown on sandy soils and during periods of excessive rainfall. These conditions require more frequent sidedress applications.

Composting

Composting is a way of recycling organic waste materials ordinarily discarded. When these materials are placed into a compost pile with soil, water and certain other materials, they decay into rich humus that can be used as mulch, applied to

Table 4.4. Composting materials and their plant nutrient values.

<i>Material</i>	<i>Nutrients</i>	<i>Material</i>	<i>Nutrients</i>
Coffee grounds	N	Livestock manure	N
Corncobs & stalks	C	Peanut shells	C, N
Cowpeas & stalks	N, K	Pine needles	N
Eggshells	C, N, Ca	Sawdust	N, P, C
Fish scraps	N, P	Fruit waste	K
Stable bedding	C, N	Grass clippings	N
Vegetable waste	N	Weeds	N
Straw	C, N	Wood ashes	P, K
Leaves	C	Alfalfa hay	N, C

*N = nitrogen, C = carbon, K = potassium, P = phosphorus

the garden as organic matter or fertilizer or worked into potting soil to improve its structure.

Composting guidelines:

- Covering the pile – not mandatory, but it can help speed up the process by trapping heat. Many kits include lids or black plastic to cover the compost. Covering the compost also makes it easier to control moisture levels.
- Ventilation of the bin – it is important to allow oxygen to penetrate the pile and is best accomplished by frequent turning of the pile. To ensure uniform decomposition, turn compost at least every seven days.
- Proper ingredients – include anything as long as it is organic. Materials most often used are leaves, grass clippings, straw, weeds (before they go to seed), kitchen scraps, manure and plant parts from vegetable and flower gardens. Livestock manure should always be composted before using in the garden, or make certain to allow enough time from manure application until planting for the breakdown of pathogens (120 days for root crops and 90 days for aboveground crops).
- Ingredients to exclude – avoid diseased plant material or plants treated with weed killers (herbicides). Do not use meat scraps, bones or cooking fats, since they can attract rodents, dogs and create bad odors. Avoid pine straw because it decays slowly. Avoid noxious weed seeds because of possible re-infestation. Never use human or pet manure because of potential unhealthy bacteria and other disease organisms.

Composting tips:

- Extension fact sheets on composting:
 - o L-252 *Don't Bag It: Leaf Composting*
 - o AGE-887 *Rural Community Yard Waste Composting Systems*
 - o BAE-1744 *Backyard Composting in Oklahoma*
 - o PSS-2911 *Compost Turning: the Key to Quick Composting*
 - o BAE-1742 *Vermicomposting: Composting with Worms*
- Shred landscape waste into smaller pieces for a quicker composting process. The size of organic material affects the rate of decay. Smaller particles decompose faster than larger ones.
- When possible, construct the compost bin of fence wire, treated wood or concrete. However, many different composting styles are available for use, including batch turning composters, bins with removable layers and small batch composters. If using the bin method, make the structure large enough to provide for two bins so the compost can be turned from one bin into the other periodically. In an ideal situation, each bin should be 3 to 5 feet wide, 4 to 6 feet high and any convenient length.
- One side of each bin should be removable for convenience in adding and removing compost material. Rectangular bins are usually easier to use.
- Carbon/Nitrogen Ratios: A goal would be to achieve a 23-to-1 to 30-to-1 C/N ratio [browns (high C) – greens (high N)].

Table 4.5. Composting materials and their carbon to nitrogen ratios.

<i>Material</i>	<i>High carbon</i>	<i>Material</i>	<i>High nitrogen</i>
Oak leaves	50:1	Grass clippings	21:1
Maple leaves	60:1	Egg shells	25:1
Ash leaves	35:1	Fruit waste	35:1
Fruit tree leaves	35:1	Humus	10:1
Pine needles	70:1	Vegetable waste	15:1
Corn stalks	60:1	Alfalfa	12:1
Sawdust	500:1	Clover (green)	16:1
Newspaper	170:1	Rotted manure	20:1
Straw	80:1		
Wood	700:1		

Table 4.6. Composting problems and solutions.

<i>Symptoms</i>	<i>Problem causes</i>	<i>Solution</i>
Bad odor	Not enough air/too wet/ too much green	Turn it in, add carbon source
Dry/not hot	Not enough water, overventilation	Moisten while turning
Damp and warm in middle, but nowhere else	Insufficient amount of compost	Collect more material and mix with old ingredients. Fill composter full with mix initially
Damp but not hot	Lacks nitrogen	Add fresh organic nitrogen or synthetic nitrogen
Clumped and gooey	Lack of air	Turn for ventilation, add carbon source

- Sufficient watering – the ideal moisture content in a compost pile is best described as damp like a sponge, but not soggy. Be sure to water the pile thoroughly during dry weather.
- Use a starter – soil or finished compost adds nutrients, microorganisms and bacteria to help start the decomposition process. If possible, use a thin amount over each layer and on top of the pile. This helps keep moisture from evaporating from the pile, which helps maintain a more uniform temperature.
- Proper temperature – to actively kill weed seeds, pathogens and insects a compost pile should reach between 130 F and 170 F, which also speeds up the decomposing process. The heating process will be greatest after each misting or turning of the pile and is an indication that the composting process is underway.
- If you have two or more bins, the material will decompose faster and create a better mixture if the compost is shoveled from one pile to another about every two months.
- Touch and Smell – finished compost will be rich and a dark color, smell sweet, cool and crumble easily. Finished compost should be ready in four to six months, depending on how well the microbial activity is sustained through proper nutrition, aeration and moisture.
- Improving soil through testing and the addition of the correct amount of plant nutrients and organic matter is a key part of maintaining soil fertility.
- Managing soil pH properly will maintain all essential nutrients at appropriate levels.
- Organic matter is a key component of a healthy and productive garden soil.
 - o Organic matter should be added to soil regularly.
 - o Addition of organic matter through plant and animal waste.
 - o Green manure crops.
- Fertilization is an important practice, but is not a cure-all for all gardening problems.
- Knowing how to read and interpret a soil test report is an important part of fertility management.
 - o If you have specific questions about your test, ask your county Extension educator.
 - o Learn how to calculate fertilizer application rates based on soil test results.
- Commercial and organic fertilizers have strong and weak points.
 - o Organic fertilizers are often more expensive, but do add organic matter.
 - o Commercial fertilizers are usually less expensive and more readily available, but don't add organic matter.
 - o All fertilizers are taken up by the plant in the same form after microbes in the soil have converted them to useable forms.

Soil Fertility Summary

- Soil health and fertility is the basis for successful gardening.

Crops and Garden Layout

The first step in planning a garden is selecting which vegetables will be grown. With a few exceptions, plant what you like to eat. Only a few vegetables may be unsuitable because of space limitations, improper climate or unusually poor growing conditions.

The second step is to draw a diagram of the garden site (Figure 4.1). The diagram should show the kind of vegetables to be planted, the distance between rows (if any) and the time of planting. Including dates will help you remember tasks that might otherwise be put off or overlooked. Plan the garden and order seeds as early as possible.

Perennial vegetables: These include asparagus, rhubarb and winter onions, and should be planted at one side or end of the garden for efficient operation. A critical issue for these vegetables includes good soil and site preparation prior to planting. This may include tillage, control of perennial weeds like Bermuda grass, soil testing and amending the soil prior to planting. These plantings could be in place for 10 years or more, so spend the time and effort to fully prepare the planting area beforehand.

Cool and warm season vegetables: Cold-tolerant vegetable crops are planted early in the season and should be planted together. When these crops are harvested, they may be followed with warm season vegetable crops. Vegetables requiring similar cultural practices should be grouped together for ease of care. Table 4.8 lists vegetable crops as cool-season or warm-season crops, indicating when they grow best. Crops classified as

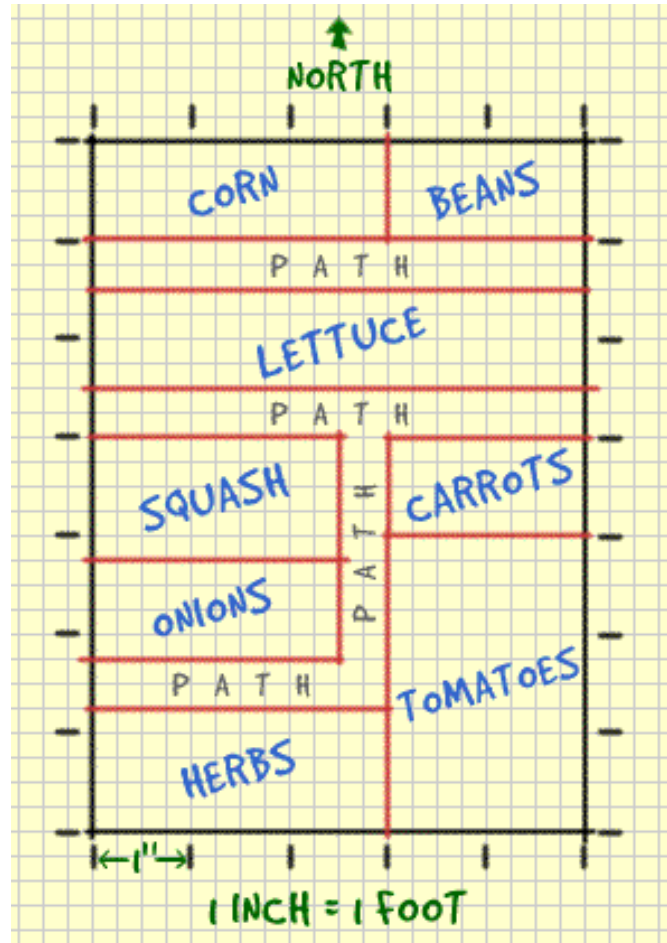

Figure 4.1. Examples of garden layout and orientation.

Table 4.7. Vegetable families.

Family	Crops
Legume Family	Peas, beans, all types
Goosefoot family	Spinach, beets, chard
Brassica family	Cabbage, collards, Brussels sprouts, kale, cauliflower, broccoli, kohlrabi, mustard, turnip, cress, horseradish, radish
Parsley family	Carrots, parsley, celery, parsnip
Nightshade family	Tomato, potato, eggplant, pepper
Squash family	Squash, pumpkin, watermelon, cantaloupe, cucumber, melon, gourd
Composite family	Lettuce, chicory, endive, escarole, salsify, dandelion, Jerusalem artichoke
Lily family	Onions, garlic, leek, chive, asparagus
Grass family	Corn

Table 4.8. Garden planning guide.

<i>Cool season vegetables</i>			<i>Warm season vegetables</i>		
<i>Vegetable crop</i>	<i>Planting time¹</i>	<i>Frost Tolerance</i>	<i>Vegetable crop</i>	<i>Planting time¹</i>	<i>Frost Tolerance</i>
Asparagus	Fall or Spring	Hardy	Bean, Lima	April 15-30	Tender
Beet	March	Semi-Hardy	Beans, Green or Wax	April 10-30	Tender
Broccoli	March	Hardy	Beans, Pole	April 10-30	Tender
Cabbage	Feb. 15 to March 10	Hardy	Cantaloupe	May 1-20	Very Tender
Carrot	Feb. 15 to March 10	Semi-Hardy	Cucumber	April 10-30 or later	Very Tender
Cauliflower	Feb. 15 to March 10	Semi-Hardy	Cowpea	June 1-30	Very Tender
Chard, Swiss	Feb. 15 to March 10	Semi-Tender	Eggplant	April 10-30	Very Tender
Kohlrabi	Feb. 15 to March 10	Hardy	Okra	April 10-30 or later	Tender
Lettuce, Head	Feb. 15 to March 10	Semi-Hardy	Pepper	April 10-30 or later	Tender
Lettuce, Leaf	Feb. 15 to March 10	Semi-Hardy	Pumpkin	April 10-30 or later	Tender
Onion	Feb. 15 to March 10	Hardy	Southern Pea	May 1- June 10	Tender
Peas, Green	Feb. 15 to March 10	Hardy	Squash, Summer	April 10-30 or later	Very Tender
Potato, Irish	Feb. 15 to March 10	Semi-Hardy	Squash, Winter	May 15-June 15	Very Tender
Radish	March 1 to April 15	Hardy	Sweet Corn	Mar. 25-April 30	Tender
Rhubarb	Fall or Spring	Hardy	Sweet Potato	May 1- June 10	Very Tender
Spinach	Feb. 15 to March 10	Hardy	Tomato	April 10-30	Tender
Turnip	Feb. 15 to March 10	Hardy	Watermelon	May 1-20	Very Tender

¹These dates indicate planting times from southeast to northwest Oklahoma. Specific climate and weather may influence planting dates. For cool season vegetables, the soil temperature at the depth where the seeds are planted should be at least 40 F, for warm season vegetables, the soil temperature at the depth where the seeds are planted should be at least 50 F. For more information about soil temperature for planting and preferred growing temperatures, see *Knott's Handbook for Vegetable Growers*.

cool-season may be planted earlier in the season (or in the fall), and thrive best with average daily temperatures of 70 F or less. Warm-season crops grow better during warm weather with the average daily temperatures ranging between 70 F to 90 F. Based on the temperatures plants will tolerate, vegetables are hardy, semi-hardy, tender or very tender. Hardy types may be planted before the last killing frost. Semi-hardy vegetables will be injured by a hard frost, but will grow in cool weather and will tolerate a light frost. Tender plants are injured or may be killed by a light frost, but can withstand cool weather. Very tender vegetables are injured by cool weather. Differences in suggested planting dates range from the earliest for southeast Oklahoma to the latest for the northwest part of the state.

Alternatives to Traditional Gardening

There are several ways to grow produce. Some of the variations below are for space-saving, while others are for special needs situations.

- Free-standing raised beds: Mound rows up with a garden rake to improve drainage and to warm soil faster in spring.
- Raised beds: Soil is held in place by some type of frame, usually wood, which can be 12 to 36 inches high. Raised beds are used to improve drainage or fertility when existing soils are poor, create a small, neatly contained garden or to make gardening easier for gardeners with physical disabilities or limitations.

- Intensive gardening: The purpose of intensive gardening is to harvest the most produce possible from a given amount of space. An intensive garden reduces wasted space to a minimum with a major goal to grow something in every part of the garden throughout the season. Below are a few intensive garden techniques:
 - o Containers: Produce is grown in a container filled with a soilless potting mix. Drainage holes are necessary to allow excess rainwater to escape. Many new vegetable varieties are excellent for containers. This is a good option for apartments, decks, and patio gardens.
 - o Vertical gardening: Plants grown in the soil or in containers are staked or trained on a trellis to grow upward. Plants may also be grown in hanging baskets.
 - o Square-foot gardening: Plants are grown in one-foot squares. The point of this method is to maximize production from available space, give vegetables the correct amount of space and minimize weed pressure.
- No-till or minimal-till gardens: This requires adding mulch regularly. Mulch is any material spread on a garden to protect root plants from heat, cold or drought; to reduce problems with weeds; and to keep fruit clean. Sheet mulching (also known as lasagna gardening) involves placing layers of mulch on top of the soil. Over time, the mulch builds on the already-existing garden soil, mimicking the natural soil-building process. This technique is best used with transplants versus direct seeding.
- Straw bale gardening - A straw or hay bale bed is a type of bed that can be used for raising vegetables (pepper, tomatoes, onion, grain amaranth, etc.), flowers, herbs and cover crops (cow peas, vetch, etc.) directly in bale(s), with the possible addition of growing media (plant nutrients) from compost, soil or other sources (Figure 4.2). Generally, the growing season and planting time for bale gardens is roughly the same as that for conventional beds.



Figure 4.2. Straw bale gardening.

weeding, fertilizer was overused and a large crop became ready to eat all at once.

Current gardening trends: Home landscapes are often much smaller now. Traditional home lots have little space for gardening, similar to town-homes or apartments. As a result, gardens have gotten smaller. What has been experienced by many is the smaller gardens for small spaces may actually produce as much or more than the larger gardens of the past. This is primarily due to having more time per square foot of garden to manage fertility, watering, weeding and pests.

Reasons for intensive gardening: Intensive gardening concentrates the work efforts to create an ideal plant environment, providing better yields with less labor and an efficient use of all resources.

Good planning a necessity: An effective, intensive garden requires early, thorough planning to make the best use of time and space. Plan your garden early by reviewing last year's records to decide which varieties were most successful or had the best flavor to help make the decisions. Choose crops based on your preferences, as well as the amount of each crop needed. Use the tables in this chapter and your experience to determine crops that perform well together. Before planting, consider the interrelationships among plants, including nutrient needs, shade tolerance, aboveground and belowground growth patterns, and preferred growing seasons.

Intensive Gardening Methods

Past gardening trends: During the 1940s, the typical family garden was spread over a large area, with 3-foot-wide paths between narrow ribbons of vegetables. The paths needed constant

Components of intensive gardens

Raised beds: The basic unit of an intensive garden is the raised bed or growing bed (Figure 4.3). Having a system of beds allows the gardener to concentrate soil preparation efforts in small ar-



Figure 4.3. Raised beds can be constructed out of just about any material.

eas, which can make the soil amendments more effective and create an ideal environment for vegetable growth. Beds are generally 3 to 4 feet wide and as long as desired. The gardener works from either side of the bed, which reduces the amount of soil compaction caused by walking.

- An advantage of raised-bed gardening is it breaks work into units. Instead of tackling an entire garden full of weeds, the gardener can weed each bed in turn. Other chores are accomplished with the same ease.
- By nature, raised beds are a form of wide-bed gardening. Seeds and transplants can be planted in wide bands of several rows or broadcast in a wide strip. In general, the goal is to space the plants at equal distances from each other so when they reach maturity, the leaves will touch on all sides. Close plantings save space, help control weeds and reduce moisture loss from the surrounding soil.

Soil preparation for intensive gardens: soil preparation is the key to successful gardening of any kind, but especially intensive gardening. To grow so close together, the plants must have enough nutrients and water. Although it will help to provide extra fertilizers and irrigation, nothing can substitute for deep, fertile soil that is rich in organic matter.

- Humus-rich soils hold extra nutrients. Existing elements are released by the actions of earthworms, microorganisms and acids in the soil, slowly releasing nutrients for plant use.
- If your soil is not deep, double dig the beds for best results. To create a true raised bed, take

topsoil from the neighboring pathways and mix well with the rest of the planting soil.

- Remove Bermuda grass/weeds in the area or choke it out with newspaper, cardboard or landscape fabric underneath the added soil.
- Because of the amount of work involved, a gardener might first try intensive gardening in one or two beds for the most valuable plants. If the results are favorable, other beds can be built as time allows.

Vertical gardening: The use of trellises, nets, strings, cages or poles to support growing plants is known as vertical gardening (Figure 4.4). This technique is especially well suited for small garden spaces, but can be used in gardens of all sizes.

- Vertically grown plants need much less ground space. Although the yield per plant may be less, the yield per square foot of garden space is much greater. Make sure the soil is deep and well drained to allow roots to extend vertically and avoid competition with other plants.
- Obvious candidates for vertical gardening include vining and sprawling plants such as cucumbers, melons, pole beans and tomatoes. Some plants, like gourds, entwine themselves onto the support. Other plants, such as melons and tomatoes, must be tied.
- Vertical plantings cast shadows, so be careful not to shade sun-loving crops. Take advantage of the shade by planting shade-tolerant crops like lettuce near the vertical crops.
- Because vertically grown plants are more exposed to sun and wind, they dry out faster and may need water more often. Rapid drying is



Figure 4.4. Trellis with vegetables growing on it is a form of vertical gardening.

an advantage for plants susceptible to fungal diseases.

Inter-planting: Growing two or more types of vegetables in the same place at the same time is known as inter-planting. Although this technique has been practiced for thousands of years, it is gaining renewed interest in the United States. For inter-planting to produce an abundant and high-quality crop, the gardener must plan carefully.

- Consider the length of the plant's growth period and its growth pattern. Is it tall, short, underground or aboveground?
- Are there possible negative effects on other plants such as competition for light, water or nutrients?
 - o Consider requirements of each crop for these elements.
- Consider the preferred growing season, cool or warm.
- Inter-plant by alternating rows within a bed, such as planting a row of peppers next to a row of onions, by mixing plants within a row, or by distributing various species throughout the bed.
- Inter-plant by mixing plants within a row, an example:

- o Long-season or slow-to-mature crops are planted the same time as short-season or quick-to-mature crops. For instance, if carrots and radishes are planted at the same time in a row, the radishes will be harvested before crowding the carrots.
- o Put smaller plants close to larger plants, such as radishes at the base of beans or broccoli.
- o Plant shade-tolerant species, such as greens, lettuce and spinach, in the shadow of taller crops.
- o Pair heavy feeders, such as crops in the cabbage family, with light feeders like cow-pea or okra.
- Inter-planting may help keep insects and disease problems under control. Pests are generally crop-specific, which means they prefer crops of one type or family.
 - o Mixing families of plants helps break up large areas of the pest-preferred crop, which helps contain early pest damage within a small area. This gives the gardener more time to control the problem.
 - o However, one disadvantage is that when pesticides are used, it is difficult to be sure that all the plants are protected.

Table 4.9. Intensive spacing guide.

<i>Crop</i>	<i>Inches</i>	<i>Crop</i>	<i>Inches</i>
Asparagus	15 to 18	Lettuce, head	10 to 12
Beans, lima	4 to 6	Lettuce, leaf	4 to 6
Beans, pole	6 to 12	Melons	18 to 24
Beans, bush	4 to 6	Mustard	6 to 9
Beets	2 to 4	Okra	12 to 18
Broccoli	12 to 18	Onion	2 to 4
Brussels sprouts	15 to 18	Peas	2 to 4
Cabbage	15 to 18	Peppers	12 to 15
Cabbage, Chinese	10 to 12	Potatoes	10 to 12
Carrots	2 to 3	Pumpkins	24 to 36
Cauliflower	15 to 18	Radishes	2 to 3
Cucumber	15 to 18	Rutabaga	4 to 6
Chard, Swiss	6 to 9	Southern pea	3 to 4
Collards	12 to 15	Spinach	4 to 6
Endive	15 to 18	Squash, summer	18 to 24
Eggplant	18 to 24	Squash, winter	24 to 36
Kale	15 to 18	Sweet corn	15 to 18
Kohlrabi	6 to 9	Tomatoes	18 to 24
Leeks	3 to 6	Turnip	4 to 6

- Individual plants are spaced closely in a raised bed or inter-planted garden. In beds with more than one row, stagger the plants so those in every other row are equally spaced from plants in adjacent rows.
- For direct seeded crops, the seed packet should give the recommended distance between plants within a row. Close spacing tends to create a nearly solid leaf canopy, which acts as a living mulch, cooling the soil, decreasing water loss and shading the soil minimizing weeds.
- Do not crowd plants to the point where disease problems develop or competition causes stunting or “leggy” plants. Table 4.9 provides guidelines for space requirements of various crops. Areas of the state with higher rainfall and humidity will need wider spacing than those in drier areas.

Succession planting: Succession planting is an excellent way to make the most of an intensive garden. To obtain a succession of crops, plant something new in the spots vacated by spent plants. An example of succession planting would be planting corn after peas. Another example of succession planting is a spring, summer and fall garden. Cool-season crops are followed by warm-season

crops, which are followed by more cool-season crops or a winter cover crop.

Relay planting: The practice of relaying consists of planting a new crop before the old one is removed. For instance, sweet corn can be planted at two-week intervals for a continuous harvest. This requires some thought as crops planted very early are likely to get a slower start due to low soil and air temperatures. With corn, having two different varieties pollinating at the same time may affect kernel quality (e.g. supersweet and other corn types cannot be mixed). For best results, give early-planted, warm season crops extra time to get started. You may achieve the same result by simultaneously planting various-maturing varieties of the same vegetable. For example, plant early-ripening, indeterminate, and heat-tolerant tomatoes at the same time to have a long harvest. Planting with transplants can overcome temperature restrictions for germination, help ensure a good stand and contribute to a more uniform harvest.

Module vegetable gardening: Modular gardening refers to developing small spaces with soil amendments so plants, especially vegetables, may be grown close together and harvested on a staggered time table. This greatly increases the potential yield from a small area.

Table 4.10. Plant groups according to nutrient needs.

<i>Heavy Feeders</i>	<i>Heavy Feeders</i>	<i>Light Feeders</i>	<i>Soil Builders/Cover Crops</i>
Asparagus	Parsley	Carrots	Alfalfa
Beets	Pumpkin*	Garlic	Beans – broad, lima, snap
Broccoli*	Radish	Leeks	Clover
Brussels sprouts*	Rhubarb	Okra	Peas
Cabbage*	Spinach	Onion	Peanuts
Cantaloupe*	Squash*	Parsnips	Soybeans
Cauliflower	Strawberries	Pepper	
Celery	Sunflowers	Potatoes	
Collards	Swiss chard	Rutabaga	
Corn	Tomatoes*	Shallot	
Cucumbers*	Watermelon*	Sweet potatoes	
Eggplant*		Turnips	
Endive		Tiller radishes	
Kale			
Kohlrabi			
Lettuce			
Mustard greens			

*Fertilize at least twice

How module gardens originate: The first method proposed to use these small spaces was the “French Intensive Method,” and later, gardener Mel Bartholomew popularized the idea of “Square Foot Gardening.” His basic recommendations are to build up the sides of the bed with 1-foot boards, creating a square box or module. For more details on modular gardening, see *Bartholomew’s All New Square Foot Gardening* (Cool Springs Press, 2006).

What comprises a module: The modular concept is derived from the uniform dimensions of the box, such as 4 feet by 4 feet, or 6 feet by 6 feet. The garden can be composed of one module or multiple modules placed near each other, leaving walkways in between. A module is filled with commercially available landscape mixes, or with a homemade soil mixture of equal parts peat moss, good blended compost, and coarse vermiculite. There is no need to worry about the underlying soil quality when working with most annual vegetables. However, always use recommended methods to remove Bermuda grass and other weeds, such as early spraying with glyphosate or laying landscape fabric, newspaper or cardboard as a barrier. Each module is then marked off in grids of 1 foot by 1 foot or 2 feet by 2 feet. Garden crops are planted into the grids, with the size of grid depending on the mature size of the plants. For example, 12 carrots can be placed in a 1-foot-by-1-foot grid, 1 tomato in a 2-foot-by-2-foot grid, 6 bush bean plants in a 1-foot-by-1-foot grid and so on.

Farmscaping: Farmscaping is a holistic ecologically-based approach to pest management that emphasizes the arrangement or configuration of plants that promote biological pest management by attracting and sustaining beneficial organisms. Ideal farmscape plantings provide habitat for beneficial insects, suppress weeds and grow in close proximity to the cash crop without competing for light, water and nutrients. Research has shown that maintaining high levels of species diversity is a key characteristic of a proper functioning agroecosystem. Unfortunately, intensive farming operations including growing large monocultures, regular cultivation and excessive use of insecticides often leads to a dramatic reduction in arthropod diversity, especially natural enemies that often keep many pest insects below damaging levels. Farmscaping is a technique designed to add diversity back to the system and minimize

disturbance, leading to increases in natural enemy populations by providing insectary plants as food and shelter resources.

Successful conservation of natural enemies involves manipulation of the environment to favor natural enemies, either by eliminating adverse factors or by providing improved conditions for colonization and survival. In addition to acting as a reservoir for natural enemies, the use of farmscaping may increase alternative prey or insect hosts when other food resources are scarce. Farmscape plantings can also serve as an overwintering habitat for natural enemies to ensure carryover of beneficial insects from year to year.

Container Gardening

Container gardening for very small spaces: If space is a limiting factor, consider growing vegetables in containers. A window sill, patio, balcony or doorstep can provide sufficient space for a productive container garden. Container gardening can also eliminate problems with nematodes, poor soil quality, poor drainage or soil-borne diseases.

Low space requiring vegetables: Grow only vegetables requiring limited space. For the best use of space use crops such as carrots, lettuce and radishes, or types which bear through time, like peppers and tomatoes. Although dwarf or miniature varieties may mature and bear fruit early, most do not produce as well as standard varieties. With increasing interest in container gardening, plant breeders and seed companies are developing vegetables specifically bred for container culture. These varieties are not necessarily miniature or dwarf, and may produce as well as standard types if cared for properly.

Light requirements: The amount of sunlight a container garden receives may determine which crops can be grown. Generally, root crops and leaf crops can tolerate partial shade, but vegetables grown for fruits generally need at least eight hours of direct sunlight each day. Available light can be increased somewhat by installing reflective materials, such as aluminum foil, white painted surfaces or marble chips around the plants.

Plantscaping: Container gardening presents opportunities for many innovative ideas and lends itself well to attractive plantscaping. A dull patio area can be brightened by baskets of cascading



Figure 4.5. Vegetables in containers on a patio space.

tomatoes or a colorful herb mix (Figure 4.5). Planter boxes with trellised pea vines can create a cool, shady place on an apartment balcony.

Containers to use: Many types of containers are suitable for gardening, including clay, wood, plastic and metal. Containers for vegetable plants must be big enough to support the plants when fully grown, hold soil without spilling, have adequate drainage and never have held products toxic to plants or people.

Consider using barrels, flower pots, window boxes, cut-off milk or bleach jugs, recycled Styro-foam coolers, baskets lined with perforated plastic for drainage, stock tanks or even pieces of drainage pipe or cinder block (Figure 4.6).

Redwood and cedar are the most rot-resistant wood, but cedar trees are much more plentiful than redwoods in Oklahoma. Avoid materials that have been used previously for industrial purposes,



Figure 4.6. Clay pipes stood on end.

such as railroad ties and other treated lumber, as they may contain hazardous chemical residues.

Some gardeners have built vertical planters out of wooden lattices lined with black plastic and filled with a lightweight medium, or out of cylinders of welded wire lined with sphagnum moss and filled with soil mix. Depending on the size of the vertical planter, 2-inch-diameter perforated plastic pipes may be needed inside the container to aid in watering.

A very enjoyable aspect of container gardening is the imaginative use of discarded items or the construction of attractive patio planters. Dollies or platforms with wheels or casters can be used to easily move the containers from place to place. This is especially useful for apartment or balcony gardening. Plants can be moved for maximum use of available space and sunlight, and plant damage can be avoided during severe weather. Container designs are only limited by your imagination.

Whatever type of container is used, be sure there are holes in the bottom for drainage, so plant roots do not stand in water. Most plants need containers at least 6 to 8 inches deep for adequate rooting.

Soil media: Vegetable gardening in containers requires a fairly lightweight potting mix. Do not use soil straight from the garden. To support plants, the container medium must be porous, since roots require both air and water. Packaged potting soil available at local garden centers is relatively lightweight and may be a good choice.

Homemade media can be made from one part peat moss, vermiculite or perlite; one part clean, coarse builder's sand; and a slow-release fertilizer (14-14-14, according to the container size). Lime may also be needed to bring the pH to around 6.5. As with a large garden, a soil test can help determine any nutrient requirements or pH adjustments.

Planting: Plant container crops at the same time as a regular garden and follow these steps:

- Fill a clean container to within half an inch of the top with a slightly damp soil mix.
- Soak mixes containing peat moss with warm water. This enables the moss to absorb the water and mix much readily.
- Sow seeds or set transplants according to the instructions on the seed package.
- Label in or on each container with the name, variety and date of planting.

- Gently sprinkle the soil with water, being careful not to wash out or displace the seed.
- When the plants have two or three leaves, thin seedlings to obtain proper spacing.
- Provide cages, stakes or other supports if needed. Avoid root damage by supporting the plants when small.

Watering: Pay particular attention to watering container plants. Because of the the nature of potting soil and the relatively small amount, containers can dry out very quickly. This is especially true on a concrete patio in full sun. Daily or even twice daily watering may be necessary. Apply water until it runs through the drainage holes. On an upstairs balcony, this may cause problems with downstairs neighbors, so make provisions for water drainage. Large trays filled with coarse gravel work well.

Decide when to water: Check soil moisture in your container garden at least once a day or twice a day if the weather is hot, dry or windy. Feel the soil to determine if water is needed. Mulch and windbreaks can help reduce the water requirements for container gardens. Gardeners who are away from home often should consider installing an automatic-drip irrigation system.

Watering issues: Never allow the soil to become soggy or stand in water. If the soil is consistently wet when the weather is cool, container plants may develop root rot. Clay pots and other porous containers may require more frequent watering, as they allow more water to evaporate from the sides of the pots than from the ground. In addition, small pots dry out more quickly than larger ones. If the soil appears to be excessively dry, such as plants wilting every day, group the containers together to create a microclimate so the foliage creates a canopy to shade and cool the soil. On a hot patio, put containers on pallets or other raised structures, allowing air movement beneath the pots and to protect from direct contact with concrete.

Fertilizing: If the soil mix has a fertilizer added, the plants should have enough nutrients for four to six weeks. For plants grown longer, add a water-soluble fertilizer at the recommended rate. Apply fertilizer solutions every five to 10 days, depending on how often you water. Slow release fertilizers can be added once every few months. An occasional dose of fish emulsion or compost will add needed trace elements to the soil. Container plants do not have the buffer of large amounts of

soil and humus to protect them from over-fertilization. Do not add more than the recommended rate of any fertilizer, as it may cause root burn and kill the plants.

General care: Vegetables grown in containers can be attacked by the same insects and diseases common to any vegetable garden. Inspect the plants regularly for foliage- and fruit-feeding insects and signs of disease. Protect plants from high heat caused by light reflection from concrete or pavement. Move containers to a cool spot, or shade during the hottest part of the day. Containers can also be moved to a sheltered location during severe rain, hail, windstorms and cold weather. The ability to easily move plants to a favorable environment is a big advantage for container gardens.

Gardening Tips

Tips

The following tips will enable having a successful garden and may help to prevent some common garden problems from occurring and overcoming those that arise:

- Keep the garden small enough to make it easy to establish and maintain. Small gardens can be more productive than large ones because they get better care.
- Have a soil test done every three to four years.
- Apply fertilizers per the recommended dose and in the proper manner.
- Use organic materials such as compost where available.
 - o Organic matter is the basis for a productive garden soil.
 - o Soil building through organic matter is a key aspect of gardening.
- Use recommended plant varieties.
- Thin crop plants and remove weeds when small.
- Use mulches to conserve moisture, control weeds, cool the soil and reduce fruit rots.
- Avoid excessive walking and working in the garden when foliage and soil are wet.
- Examine the garden often to stay ahead of potential problems such as weeds, insects and diseases.
- Clean tools and sprayers after use.
- Rotate specific crop family locations each year to avoid soil-borne diseases.
- Harvest vegetables during the cool hours of the day for best quality.

Things to avoid

- Planting too large of a garden: Keep it manageable!
- Planting too closely complicates walking or working in the garden.
- Placing fertilizer too close to plant stems, roots or seeds.
- Cultivating too deep will result in pruning plant roots, destruction of the soil profile and bringing weed seed to the surface.
- Planting crops and varieties not recommended for your area; however, give new releases a try.
- Watering excessively so the soil is always wet and soggy.
- Allowing weeds to grow large, flower and set seed before weeding.
- Applying chemicals or pesticides in a haphazard manner without following label directions or proper mixing.
- Using chemicals not specifically recommended for garden crops.
- Storing leftover diluted chemical sprays.

Additional tips

- Generally, a north-to-south orientation of rows is preferred. This allows crops to take full advantage of available sunlight.
- In areas of extreme slope, terrace the rows allowing water to be slowed and intercepted.
- To limit shading, place the tallest plants toward the north end of the garden.
- For ease of care, group plants together that require similar management practices. For example, group all brassica crops such as cabbage, cauliflower and broccoli. This makes spraying for common pests easier and limits the area of the garden where chemicals are used.
- To save space, try intercropping. For example, plant pole beans with corn so the beans can use the corn stalks for support, or grow pumpkins between the corn rows.
- Successive planting is another way to increase productivity. When early maturing crops are harvested, plant other crops in their place. For instance, follow spring salad crops with snap beans, zucchini or brassica crops for a fall harvest.
- Extend the harvest by making several direct plantings of quick-maturing crops such as beans, leaf lettuce and radishes. This can

spread out harvest and make it more manageable. If preservation is the main goal, plan the harvest so you are not overwhelmed by the amount, but have enough produce to make the processing job worthwhile.

- Record keeping: It is always a good idea to keep records of the garden. Keep a folder or a garden journal with the valuable information such as varieties of vegetables grown and how well they performed, frost dates, seed sowing and transplanting times, pest problems and control, rainfall, expected harvest dates, yield, quality and flavor. A map of locations where different crops are planted each year helps you decide what crop rotations to use. This information will be valuable when planning future gardens.

Soil Tillage

Tillage of soil can be done a number of ways including by hand with a shovel or other digging tool, rototiller or even a tractor and plow. Work only when soil moisture conditions are right. To determine the moisture level, pick up a handful of soil and squeeze it; if it stays in a mud ball, it is too wet. If the soil crumbles freely, it is the right consistency. Excessively dry soil may be too hard, or if already loose, can be powdery, clumpy and may be difficult to work. Working excessively wet soils can destroy the soil structure, which can take years to rebuild. Plowing wet soil with a tractor is especially damaging, because it forms a compacted layer of soil-inhibiting root growth. Soils with enough humus generally allow more leeway because of improved structural qualities. Just before planting, break up large clods of soil and level the bed with a rake. Small seeds germinate best in smooth, fine-surfaced soil. Do not pulverize the seedbed soil — this destroys the structure, which promotes crusting, erosion and plant growth will be poor. Rototilling is sufficient for most home gardens. It works well because it mixes the upper soil layers rather than turning them over. However, rototilling can cause a compaction layer to develop just below the reach of the tines.

To prevent or alleviate soil compaction:

- Use deep-rooted cover crops, which are usually grasses or legumes planted in the garden in autumn and left to rot or form a mulch layer, or be incorporated into the soil in the spring.

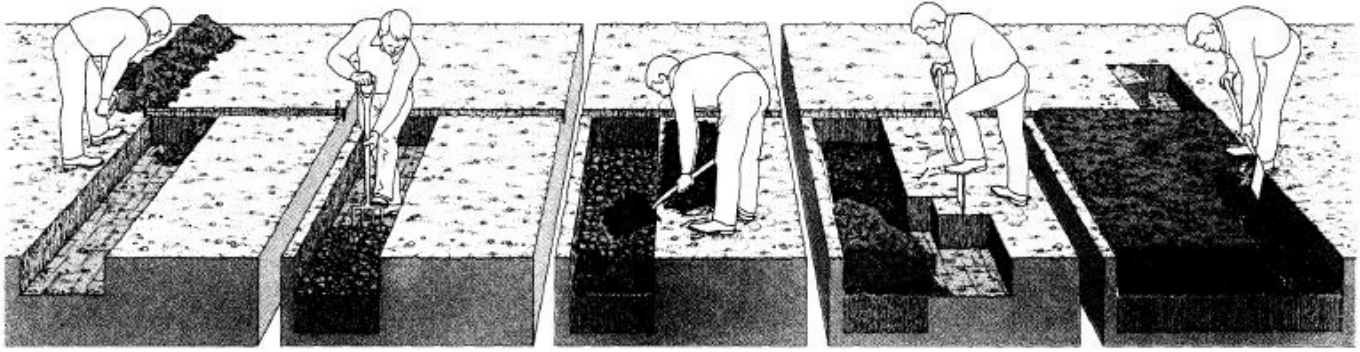

Figure 4.7. Double digging method.

- Don't work garden soil when it is overly wet. After squeezing a handful of soil in your palm, the resulting ball of soil should break up easily. If not, it is too wet to work and will become compacted when walking in and tilling the garden.
- Double-dig the garden. In double-digging, the soil is loosened to about 2 feet deep, and the top layer is fertilized with organic matter.
- Steps for double-digging:
 - o Remove the top 12 inches of soil from the bed.
 - o Insert a spade or spading fork into the soil in the bed and wiggle the handle back and forth to break up any compacted layers. Do this every 6 to 8 inches throughout the bed.
 - o Mix the topsoil with a generous amount of compost or manure and return the mixture to the bed. It should be somewhat fluffy and may be slightly raised.

Selecting Gardening Equipment

The equipment needed to prepare and maintain a garden depends on the garden size and the gardener's physical ability, time and budget. Gardeners with small gardens and modest budgets can operate well with a spade, shovel or spading fork for their primary tillage tool; garden rake for finish work; and a hoe for weeding and making furrows. If the budget allows, a powered rototiller may be used to reduce the effort to till if desired. For those with a large garden, consider a small garden tractor or a full-sized farm tractor. In addition, a mechanical seeder makes direct seeding easier. When purchasing tools, consider the garden size, the jobs to complete and the amount of money be-

ing spent. In the long run, good quality tools will give better results, stay sharp longer and last a lifetime if cared for properly.

Essential equipment:

- Primary tillage tool (one at least)
 - o Shovel
 - o Spade
 - o Spading fork
- Finish tool
 - o Garden rake
- Weeding tools
 - o Hoe
 - o Scuffle hoe
- Sharpening tool (one or the other)
 - o Hand file
 - o Bench grinder
- Gloves to protect your hands
- Irrigation equipment
 - o Sprinklers and hose
 - o Soaker hose
 - o Drip irrigation equipment
 - o Timers

Tool care:

- Purchase quality tools and perform regular up-keep and maintenance.
- Oil wooden handles with vegetable oil.
- Store out of the weather.
- Clean and oil digging tools like shovels, spades and hoes.
- Sharpen digging tools with a hand file or grinder.
- If you have power tools, maintain them with clean fuel and regular service.
- Note: If you keep your tools clean, rust-free and sharp they will require much less effort to dig, hoe or manipulate.

Garden tool descriptions

- Spades
 - A spade with a sharp edge is used for turning the soil and incorporating organic matter.
 - A four-pronged fork is good for mixing a compost pile.
 - A round-pointed shovel is good for turning soil and can also be used to harvest large-rooted crops such as Irish potatoes and sweet potatoes.
- Rake
 - A bow rake is good for smoothing out soil, removing stones and breaking up clods.
 - A straight rake is designed so the back can be used to smooth the seedbed and to compact soil over freshly sown seed for improved germination.
- Hoe – these come in all shapes, sizes and models. The hoe is used for preparing the seedbed, and for cultivating the soil to mix in fertilizer and control weeds.
 - A common or square-bladed filed hoe is good for most garden jobs.
 - A pointed or Warren hoe is good for opening a furrow by string and for cultivating between plants.
 - A scuffle hoe is made in several patterns with a flat bottom that cuts weeds off under the soil surface and breaks up the crust layer on top of the soil. It is pushed back and forth between the rows.
- Long-handled cultivator – breaks up large clods and refines the seedbed.
- Hand trowel – for transplanting vegetable plants.
- Hand cultivator – for working around vegetable plants and breaking up soil clods. For light replanting.
- Irrigation equipment –
 - Watering can for transplanting.
 - Garden and soaker hoses and sprinklers
 - Drip irrigation components for general watering.
 - Electronic timers for turning water on and off.
- Hand duster – used to apply pesticides in powder form.
 - Sock duster (use a discarded sock tied to a stick for an inexpensive duster)
- Sprayers – used to apply pesticides in liquid form
 - Compressed-air sprayers are a popular piece of equipment for applying pesticides because it gives good coverage, especially to the underside of plant leaves.
 - Hose-end sprayers are relatively inexpensive and have good coverage, especially to the underside of plant leaves.
- String and stakes – For row alignment.
- Measuring stick – For determining the distance between plants and rows.
- Wheelbarrow or garden cart – Makes moving soil, stones, tools and harvested vegetables much easier.
- Cultivator – For removing weeds and preparing the soil.
 - Wheel cultivator – for keeping soil loose and uprooting small weeds.
 - Power cultivator – a small gas or electric tiller for keeping soil loosened.
- Spreaders – for fertilizer and some amendment applications.
 - A drop spreader covers less area than a broadcast spreader with each pass over the site, but the area covered is easier to detect.
 - A broadcast spreader applies materials uniformly, although the margins of the area covered may be difficult to see.
- Hand seeder – Can reduce bending when planting. Some can open the furrow, drop the seed and cover the seed in one operation. The majority of the hand seeders are adapted to a wide variety of seed sizes.
- Tiller – Makes soil preparation easy for gardeners who prefer it, and will use it enough to make the purchase worthwhile.
 - Three types are available; all of them are driven by gasoline or electric motors.
 1. Front-tine tiller
 2. Rear-tine tiller. Many tillers with rear-mounted tines have a reverse gear that makes it possible to work in cramped areas.
 3. Mid-tine tiller. Combines the advantages of the other two types.

Seed for the Garden

One of the most enjoyable gardening pastimes is thumbing through colorful catalogs and dreaming of the coming season's harvest. Before you

start, do some homework to help you select the best varieties for your garden. There are several sources of information available to help you make decisions. First, review Extension fact sheet HLA-6032 *Vegetable Varieties for the Home Garden*, which lists varieties for home gardens. It also provides a list of seed companies and how to contact them via phone or the internet. Second, if you've been keeping notes in your garden journal, review them to see how previous varieties have performed. Last, you may choose to review research reports from different universities to read up on recently completed variety trials. Oklahoma State's Vegetable Trial Report is published each year and often contains several variety trial reports, it can be found at: <http://www.hortla.okstate.edu/industry/vegetables/index.htm>. In conclusion, realize your garden is the best place to try new varieties. Each year brings unique conditions; even if you have found the tomato variety of your dreams, try a new one or two as well.

Seed purchased from a dependable company provides a good start toward realizing a vision of bounty. Old seeds bought at bargain prices may be more trouble than they are worth. In many cases, germination will be poor and the seedlings produced may often be weak and grow slowly. Make sure the seeds you purchase were produced for the current gardening year. The seed packet is stamped with a statement indicating the year they were packed. Bulk vegetable seed is sold by the ounce or pound in garden centers and farm feed stores. This seed is shipped to the store in a container or bag with a date and germination rate label attached. Look for this information before making a purchase. Seeds with higher germination rates should be your first choice.

Keep notes about the seeds you buy – their germination qualities, plant vigor, tendencies toward insects and diseases and other information. A great place to keep this information is in a garden journal along with other garden records. These notes can help determine whether a seed company is meeting your needs, or whether the varieties chosen are unsuitable for your area or gardening style. For example, if powdery mildew is a big problem on plants in the area, next year look for varieties resistant to mildew.

Saving seed: Whether saving purchased seed or seed from open pollinated crops in your garden, all seed should be stored cool and dry, be-

low 50 F and low relative humidity (12 to 15 percent). Saving vegetable seeds offers a sense of self-sufficiency and saves money. It can maintain a variety not commercially available, thus helping perpetuate a broad genetic base of plant varieties. A seed-saver's exchange can enable you to trade extra seeds for unusual types unavailable through other sources.

Seed saving considerations:

- Use only open-pollinated varieties for home seed production. Some seed dealers have responded to the increasing interest in saving seed by clearly marking open-pollinated varieties in their catalogs.
- Do not save seed from hybrid varieties. Hybrids are the first generation (F1) seed from a very specific cross and the next generation (F2) of seed that you would collect will be segregating. You never know what qualities will be present in the offspring.
- Take care to not carry seed-borne diseases into next year's crop. Many commercially grown seeds are grown in dry areas unsuitable to fungal, viral and bacterial diseases present in other regions.
- The amount of time for seeds to dry can be increased by frequent rain and/or high humidity.
- Saving seeds from cross-pollinated crops is not recommended for the novice because of biennial habits, genetic variability, problems with selection and the requirements for hand pollination and isolation.
- Some common self-pollinated, annual plants from which seeds are easily saved are beans, herbs, lettuce, okra, peas and tomatoes.

Seeds can easily be tested for viability to determine if they are good. Count out 20 seeds and place them on a wet paper towel, allowing excess water to drain off. Place this in a closed food storage container. Place in a location where temperatures remain close to 80 F. If seeds are good, they should germinate within one week. Uniform germination indicates good quality, while erratic germination indicates poor seed. If just a few seeds germinate, discard the seed or plant extra to yield the desirable number of plants.

The depth to plant seeds depends on several factors, including seed size, soil type and season. In general, vegetable and flower seeds should be covered about two to three times their width. How-

Table 4.11. Viability of vegetable seeds.

<i>Vegetable</i>	<i>Years viable</i>	<i>Vegetable</i>	<i>Years viable</i>
Asparagus	3	Lettuce	5
Bean	3	Muskmelon	5
Beet	4	Mustard	4
Broccoli	5	Okra	2
Brussels sprouts	5	Onion	1
Cabbage	5	Parsley	2
Carrot	3	Parsnip	1
Cauliflower	5	Pea	3
Celery	5	Pepper	4
Chinese cabbage	5	Pumpkin	4
Collard	5	Radish	5
Corn	5	Rutabaga	5
Cress, water	5	Spinach	5
Cucumber	5	Squash	5
Eggplant	5	Sweet corn	1
Endive	5	Tomato	4
Kale	5	Turnip	5
Kohlrabi	5	Watermelon	5
Leek	1		

Note: Seed should be stored at cool temperatures and low humidity to prolong viability. (40 F to 50 F and 12 to 15 percent moisture).

ever, always read and follow the seed packet directions. Some seeds require light for germination and should not be covered at all. These instructions apply to seeds planted both indoors and outdoors.

Many seeds can be sown directly into the garden including beans, beets, carrots, celery, Swiss chard, sweet corn, cucumber, eggplant, lettuce, melons, okra, onion, parsley, peas, pepper, radish, spinach, squashes, tomatoes and turnip. Young seedlings can emerge easily from sandy soil or soil with high organic matter. If the garden soil has a high silt or clay content, cover the seeds to only two to three times their diameter. In such soils, apply a band of sand, fine compost or vermiculite 4 inches wide and ¼ inch thick above the row after the seeds are planted. This helps retain soil moisture and reduces crusting, making it easier for seedlings to push through the soil surface.

Soil temperature affects ability of seeds to sprout and establish a stand. In the spring, the soil can be cold and the seeds of some plants will rot

before they have a chance to sprout. In the fall, the soil can be too warm for cool-season crop seeds to germinate. Optimum soil temperatures for germination can range from 50 F to 85 F, depending on plant type. Soil temperatures can be determined by visiting the Mesonet web site (<http://www.mesonet.org/>). Mesonet is a world-class network of environmental monitoring stations located throughout Oklahoma. Each station collects data regularly and records it on the web site, including measurements of air temperature, wind, soil moisture, temperature, etc.

When planting a fall garden in midsummer, you will be working with hot and dry soil, so cover the seeds to four to five times their diameter. To promote germination, gently water them each day with a fine spray or sprinkling can. Retain moisture with a shallow mulch layer. Shading the area may keep the soil cooler for seed germination, especially when planting cool-weather crops in the summer. Another option is to plant in the bottom of a narrow and shallow trench (2½ to 3 inches). Run the trench north to south to minimize the amount of time the trench is exposed to the sun. Direct seed in the trench bottom and cover seeds to recommended depth. Further soil cooling can be obtained by shading the trench as mentioned above. See fact sheet HLA-2009 *Fall Gardening* for more information. Seed requiring a lower germination temperature may benefit from first sprouting indoors or from storage in the refrigerator two weeks before planting.

When the soil is cooler in the spring, poor germination is likely to occur if the vegetable seeds are planted too deep. As a general rule, plant the seeds no deeper than two to three times their greatest diameter. Again, sprouting indoors can be very helpful in obtaining a stand in a cold soil.

The garden soil should contain enough moisture at seeding to initiate germination. If it does not, water the soil thoroughly to a 4- to 6-inch depth, allowing it to dry just enough to be workable. If you prefer, water can be applied directly to the open furrow to moisten the soil 3 to 4 inches deep. Once the soil in the bottom of the furrow is properly moistened, plant the seed and cover firmly with dry soil.

Be aware of soil crusting: the formation of a hard, crusty layer at the soil surface. If crusting occurs shortly after seeding, it can prevent seedlings from emerging. Soil crusting normally occurs after

Table 4.12. Optimum temperatures for vegetable seed germination.*

<i>Cool season vegetables</i>			<i>Warm season vegetables</i>		
<i>Vegetable crop</i>	<i>Minimum/Maximum temperature (F)</i>	<i>Optimum temperature (F)</i>	<i>Vegetable crop</i>	<i>Minimum/Maximum temperature (F)</i>	<i>Optimum temperature (F)</i>
Asparagus	50/95	75	Bean, Lima	60/95	80
Beet	40/95	85	Beans	60/95	80
Cabbage	40/100	85	Cantaloupe	60/100	90
Carrot	40/95	80	Cucumber	60/105	95
Cauliflower	40/100	80	Cowpea	72/100	85
Chard, Swiss	40/95	85	Eggplant	60/95	85
Kohlrabi	40/90	80	Okra	60/105	95
Lettuce, Leaf	35/85	75	Pepper	60/95	85
Onion	35/95	75	Pumpkin	60/100	90
Peas, Green	40/85	75	Squash,	60/100	95
Radish	40/95	85	Sweet Corn	50/105	95
Spinach	35/85	70	Tomato	50/95	85
Turnip	40/105	85	Watermelon	60/105	95

* Temperatures from *Knott's Handbook for Vegetable Growers*, fourth edition.

heavy rain or the use of an overhead sprinkler. It is also associated with soils containing low levels of organic matter.

The problem can be alleviated by:

- 1) incorporating 2 to 4 inches of organic matter into the soil before planting;
- 2) covering seeds with organic matter rather than soil; and
- 3) not using an overhead sprinkler for watering and hope a heavy rain will not occur before the seedlings have emerged.

Row planting can make large beds easier to manage, but not necessary in a small garden planted on the square. To mark a straight row, drive two stakes into the ground at either end of the garden and draw a string taut between them. Shallow furrows suitable for fine seeds can be made by drawing a hoe handle along the string. For deeper furrows, use a corner of the hoe blade. Early in the spring, sow the seeds at a shallow depth so plants will come up quickly. Later in the summer, sow the seeds deeper to ensure a good moisture supply and cooler soil temperatures. Small seeds are difficult to distribute evenly. They are easier to space if thoroughly mixed with dry sand or dry pulver-

ized soil before planting. Drilling is spacing seeds more or less evenly down the row. Beans and peas are often planted in this way. In drilling, plant the seeds closer than the desired final spacing. After germination, extra plants are removed to give the desired spacing.

Seeds large enough to handle can be planted by hilling or row planting. Hilling is placing several seeds in one spot at definite intervals. Squash, pumpkins and melons are often planted this way. Once the seeds germinate, the hills are thinned, leaving one or two plants per hill, depending on the vegetable. In hilling, always plant more seeds than the desired number of plants. If your seeds are one or more years old, plant them thicker than you would fresh seeds. Planting extra seeds allows for poor germination and loss of seedlings to disease and insects. Once you place the seeds, cover them with soil; firm the soil (but do not pack it) around the seeds with the flat blade of the hoe or with your hand or foot. Be careful not to plant seeds too deep. Seeds covered with too much soil may never come up.

Wide rows are formed by broadcasting the vegetable seeds in a band 10 to 30 inches wide rather than a single row. The resulting spacing between plants is much closer.

- Wide-row gardening offers two advantages:
- Two to three times more food can be produced in the same amount of space for the work performed.
 - The close spacing of the plants allows them to serve as a living mulch canopy shading the soil, thus discouraging weeds, keeping the soil cool and conserving moisture.
 - Crops such as radishes, carrots, beets, onions, leaf lettuce, peas and beans are best suited to planting in wide rows. Other vegetables such as tomatoes, eggplant and melons are typically planted in single rows. Sweet corn is best planted in blocks of three to four rows rather than one long row.

Thinning vegetable seedlings is not for the faint of heart. However, thinning provides a better environment for the remaining seedlings by giving them the proper spacing for good growth and development. Some of the reasons for thinning are:

- Thinning reduces competition for moisture and nutrients among the seedlings.
- It can reduce some early disease problems by providing better air circulation around the plants.
- It provides conditions that are more ideal for growing healthier vegetables of the desired weight, size and shape.
- Properly spaced vegetable plants produce higher yields.

Start thinning when the plants have one or two pairs of true leaves. Normally, the plants will be about 3 inches tall. Thinning can be accomplished by selectively pulling plants or by clipping off at ground level with a pointed scissors. The ideal time for thinning is when the soil is damp and soft but not excessively wet. If the soil has become dry, water the site for an hour or more before thinning. Evening is a good time to thin because the remaining plants have the cool, dark night to recover from any disturbance. Crops sown thickly should be thinned so there is enough room to put a finger between the plants. Practically every direct-seeded vegetable will benefit from thinning. However, thinning is a must for leaf lettuce, beets, radishes, carrots, spinach and turnips. The only alternative to thinning is precision seeding or the use of transplants.

Transplants for the Garden

Reasons for using transplants: Most gardeners use transplants for earlier harvest, to lengthen the harvest season or to give long-season plants a chance to grow to maturity under preferred weather conditions. In most of Oklahoma, cool-season crops such as broccoli, cauliflower and cabbage would not have a chance to reach their prime harvest stage in the spring or fall if not given those extra weeks indoors to get a head start. Eggplants, peppers and tomatoes might not produce at all if not grown from transplants. Because of the amount of time, attention and controlled growing conditions needed, many gardeners buy transplants for their gardens. However, to get a larger selection of varieties and control plant production from seed to harvest, other gardeners start their own plants. Table 4.13 lists several different vegetables according to how easily they can be transplanted.

To start seed indoors, there must be enough light. This factor probably accounts for the loss of more homegrown seedlings than any other. Vegetable seedlings grown under low-light conditions are likely to be leggy and weak, and many fall over under their own weight when 3 to 4 inches tall. Place seedlings in a sun porch or a window with a southern exposure, if possible. If bright sunlight is not available, the seedlings can be grown under fluorescent lights. A simple fluorescent light fixture with grow lights or with one warm-white and one cool-white bulb will suffice. Place the light fixture

Table 4.13. Ease of transplanting.

<i>Easily survives transplanting</i>	<i>Requires care in transplanting</i>	<i>Not successfully transplanted by usual methods</i>
Broccoli	Beets	Beans
Cabbage	Chard	Carrots
Cauliflower	Cucumber	Corn
Eggplant	Melons	Mustard
Chinese cabbage	Parsley	Okra
Lettuce	Spinach	Peas
Onion	Squash	Radish
Peppers		Turnips
Sweet potato slips		
Tomatoes		

about 6 to 8 inches above the seedlings, and leave the light on for 14 to 16 hours each day. Be sure to raise the lights as the plants grow. In some cases, lights may be closer to plants and used 24 hours per day.

Media for growing transplants may range from a completely artificial material, such as vermiculite or perlite, to field or garden soil. In most instances, topsoil from the garden is not suitable because it dries out rapidly, becomes hard, lacks good physical condition, may be too fertile or not fertile enough, and may contain fungi that cause damping-off disease. To sterilize topsoil, bake it in an oven at 200 F until the internal soil temperature reaches 180 F for at least 30 minutes. Although this process is smelly, it works. If the garden soil is clay, condition it with compost or perlite to improve internal drainage.

Success is greatly increased by using commercially prepared potting mixes. Standard soil mixes for growing seedlings are available. Commercial mixes contain various proportions of materials such as peat, perlite, vermiculite and sand. Although slightly more expensive in terms of materials, these artificial mixes produce excellent transplants. Growth is more uniform, rapid and easily controlled with soil mixes. In addition, sterilization by the grower is not necessary when commercially prepared mixes are used.

Many types of containers can be used to start seeds. Flats or other large containers may be used until the seedlings have one or two sets of true leaves. At this point, move them into larger containers until they reach the right size to transplant outdoors. Seedlings also can be started in pots, old cans, cutoff milk cartons, margarine tubs, egg cartons or other containers normally discarded. Drainage holes will need to be made when using these types of containers. The pop-out trays from garden centers are reusable and easy to use. If reusing containers, be certain to wash and sanitize containers prior to use.

Peat pots are especially suited for large seeds and herbs. Sow one or two large seeds or 10 to 12 small herb seeds directly into each peat pot. Thin large seeds to one seedling per pot, but allow all the herb seeds to grow together, since they support each other and grow better than when sown singly. Herbs will be strong enough to be divided at transplanting. Peat pots may be planted directly in the garden. Do not allow the edges of

the pot to extend above the soil, as they will act as a wick and cause moisture to evaporate from the exposed surface. Another option is to use preformed peat pellets or cubes, which require no additional soil mix. Soak the pellets or cubes until they are thoroughly wet, then plant the seeds in the preformed holes. The whole pellet or cube can be planted without disturbing the roots. The only disadvantage to this method is the expense.

Regardless of the type of container chosen, fill it three-quarters full with seed-starting mixture. Sow the seeds, covering to the specified depth and water. If your home atmosphere is dry, cover the containers with polyethylene plastic to maintain a constant moisture level until the seeds germinate. Although seeds and seedlings are extremely sensitive to drying out, do not keep them soaking wet. This encourages damping-off, a fungal disease that kills seedlings. Prevent or diminish damping-off by sprinkling milled sphagnum moss, which contains a natural fungicide, on top of the soil or use seeds treated with fungicide.

If you are not starting the seedlings in their finished pot, begin transplanting seedlings when the first true leaves are forming, usually two to three weeks after sowing. Set the seedling at the same depth or slightly deeper than it was growing in the seedling flat. Take care in firming the soil around the plant to avoid injuring the tender stems. Handle seedlings by their cotyledons to prevent damage to the seedling stems. After transplanting, water seedlings thoroughly to prevent wilting. Table 4.14 lists the spacing for transplanting to other flats or containers. Later, individual plants, flats or containers may be spaced further apart to improve plant quality.

A common problem is damping-off and root rot due to excessive watering. Transplants should never be overwatered except to flush excess salts from the growing medium. Slight wilting of plants occasionally is not harmful. Adjust water, temperature and nitrogen fertilizer to control growth when plants are growing too fast.

Gradually harden plants for a week before transplanting them into the garden. Hardening prepares plants to withstand conditions such as chillier, higher temperatures, drying winds and water shortages. Slightly stress the transplants by reducing water, withholding nitrogen fertilizer and moderately lowering temperature to harden transplants. This can be accomplished by moving the

Table 4.14. Vegetable transplant growing guide.

Vegetable	Weeks to Mature Transplants (Weeks)	Seeding Depth (Inches)	Germination Temps. (F)	Plant Growing Temps.		Transplant spacing (inches)
				Day	Night (F) ^a	
Cabbage	5 to 7	1/2	70 to 80	60 to 70	50 to 60	1½ x 1½ ^b
Cauliflower	5 to 7	1/4 to 1/2	70 to 80	60 to 70	55 to 60	2 x 2 ^b
Broccoli	5 to 7	1/4 to 1/2	70 to 80	60 to 70	50 to 60	2 x 2 ^b
Brussels Sprouts	5 to 7	1/4 to 1/2	70 to 80	60 to 70	50 to 60	2 x 2 ^b
Head Lettuce	5 to 7	1/4 to 1/2	60 to 75	60 to 70	50 to 60	1½ x 1½ ^b
Onions	8 to 10	3/8	65 to 80	60 to 70	45 to 55	-----
Celery	10 to 12	1/8	60 to 70	65 to 75	55 to 65	1½ x 1½ ^b
Tomatoes	4 to 6	1/4 to 1/2	70 to 80	70 to 80	60 to 65	2 x 2 ^b
Peppers	6 to 8	1/4 to 1/2	75 to 85	70 to 80	60 to 70	2 x 2 ^b
Eggplant	6 to 8	1/4 to 1/2	75 to 90	70 to 80	65 to 70	2 x 2 ^b
Cucumber	3 to 4	3/4 to 1	70 to 95	70 to 90	60 to 70	3 x 3 ^c
Muskmelon	3 to 4	3/4 to 1	75 to 95	70 to 90	60 to 70	3 x 3 ^c
Watermelon	3 to 4	3/4 to 1	70 to 95	70 to 90	60 to 70	3 x 3 ^c
Squash (Summer)	3 to 4	3/4 to 1	70 to 95	70 to 90	60 to 70	3 x 3 ^c

^a Reduce day temperatures 5 F to 10 F during cloudy weather.

^b Space for growing in flats.

^c Space for growing directly in individual containers.

transplants to a protected area outside where they will be exposed to outdoor conditions, but still be somewhat protected. Harden off plants for three to five days prior to planting.

A young transplant is much better than an old transplant. One of the most common errors made by transplant growers is to start plants too early in the season. When held too long before planting, transplants become old, woody and are slow to resume growth after transplanting. For maximum season's yield, transplants should never have fruit, flowers or flower buds before transplanting. An ideal transplant is young and growing fairly rapidly, but slightly hardened at transplanting time. Rapid growth following transplanting assures the transplant will be well established before stress from warm weather and developing fruit.

Follow these steps to produce disease-free transplants:

- Use clean seed from a reliable source that is treated to protect seedlings from disease-causing organisms.

- Use clean growing containers; free of disease-causing organisms.
- Use a good quality, sterilized planting medium free of disease-causing organisms.
- Follow strict sanitary practices.
- Keep plants and soil from remaining wet for long periods of time.
- To help prevent damping-off diseases, keep growing media on the dry side, use treated seed. It may be necessary to use fungicide sprays or drenches.

Transplants of annual vegetables should have roots that are white and fuzzy, not brown and slimy. The plants should be short and stocky, have good leaf color, contain no flowers or fruit and be healthy with no disease or insects present. Be sure the plants have been hardened off properly, as successful transplanting is achieved by interrupting plant growth as little as possible.

Before transferring plants to the garden, make sure the soil has been properly prepared. If the

soil is dry, water a day or two before transplanting so soil is moist, but not wet or muddy. Several weeks before planting, incorporate all additives that require time to break down, such as manures, limestone, rock fertilizers and green manures. Just before planting, quick-acting material such as hydrated lime, fertilizers and well-decayed compost can be added.

To prevent wilting, try to transplant on a cloudy day or in early evening so the plants will suffer less water loss than on a hot, sunny day. Bare-root plants should be allowed to soak in water for 30 minutes to one hour to replenish water loss before planting. Handle plants carefully to avoid disturbing the roots and bruising the stems. Water transplants immediately after being set into the soil. For container-grown plants, use a trowel to dig a hole large enough to accommodate the container. Peat and other fiber pots can be set directly in the planting hole; they will disintegrate in the ground. Do not leave the edge of the pot exposed, as it will wick water away from the transplant. For most types of vegetables, place the transplant in the ground slightly deeper than it grew in the container. Tomato plants are an exception; they will develop



Figure 4.8. Trench planting tomatoes.

roots all along the stems when planted sideways in a trench, leaving only two or three sets of leaves exposed (Figure 4.8). This works particularly well for leggy tomato transplants.

Protect young transplants against heat, cold and damaging winds the first several days after transplanting. When unfavorable conditions threaten, place boxes, baskets, plastic milk jugs or flower pots over the transplants (Figure 4.9). However, do not leave the protectors over the plants longer than necessary. If it gets warm during the day, remove the covers to provide proper ventilation for the plants. A shingle stuck in the ground at a slant on the south side of a plant can serve as a sunshade. Water the plants once or twice during the week, depending on the amount of rainfall received.



Figure 4.9. Wall O' Water® Season Extenders protecting tomato plants.

Summer Care

One of the most important factors for successfully growing vegetables in Oklahoma is the summer care given to the garden. The gardener naturally wants to give his or her garden the best care possible. To accomplish this, the gardener must have a basic knowledge of how to properly irrigate, control weeds, use mulches and control diseases and insects.

The majority of full-season vegetables need about 20 inches of water during the growing season for good growth. Vegetable crops in general require irrigation to thrive and produce adequately. The water in the soil may come from rainfall or from irrigation. The following guidelines will help determine the amount and method of irrigation necessary for your garden.

A plant can only use the moisture in contact with its seed or roots. After the seed germinates, roots are produced, which continuously extend into increasingly greater volumes of soil where the plant can obtain water. Therefore, only the soil around the seed needs to be kept moist following planting. As plants develop, and when growing vegetables from transplants, it is best to keep the soil moist to a depth of about 1 foot or more. After seeds have been planted, the soil may be moistened with a hand-held hose or drip irrigation to maintain moist soil conditions until seedlings emerge. During May and June, garden plants will use about 1 inch of water each week. In July, August and September, they require about 2 inches of water per week for best growth. It normally takes this amount of watering per week to maintain production if there is no rainfall.

One way of determining when to irrigate is to take a soil core sample from the plant root zone (6 to 8 inches deep) and squeeze it into a ball. If the ball holds together in the palm of your hand, the soil has sufficient water. If it crumbles, water can be applied. A tensiometer is a fairly economical instrument that can be used to monitor soil moisture and aid in determining when to start and to stop watering. Water-conscious gardeners may want to consider using these devices.

At the crumble-stage, the average soil will hold an inch of water per foot. If water is to be applied with a sprinkler, the delivery should be determined by placing three or four cans with straight sides under the sprinkler pattern. This will illustrate how long it takes to accumulate an inch of water. Water consumption for a garden will gradually increase to two inches per week during hot weather, and taper off as the weather cools. Light, frequent irrigations are not useful or recommended.

Home gardeners have several options for watering plants: a garden hose with a fan nozzle or spray attachment, portable lawn sprinklers, a perforated plastic soaker hose, drip or trickle irrigation or a semiautomatic drip system. If maintained properly, quality equipment will last for several years.

Sprinkler irrigation is a common method used by home gardeners. A sprinkler should apply water uniformly and at a rate slow enough to prevent runoff. A sprinkler should not produce a mist subject to drifting. It is preferable to use a sprinkler that will water the garden all at once, so walking

into a wet garden won't be necessary when moving it. When using a sprinkler, it is best to irrigate early in the morning, so plant foliage can dry off quickly, reducing the chance of diseases.

Furrow irrigating with a garden hose is one of the least efficient methods of irrigation for home gardens. It should not be used unless the rows are quite short. While furrow irrigating does reduce evaporation losses, it poses several disadvantages. It causes erosion, and the hose needs to be moved each time a row has been irrigated. In addition, percolation is often heavy at the upper end of the garden, moving water below the root system, which is then lost.

Soaker irrigation hose is a porous material, usually consisting of a canvas hose, 20 feet or more in length, which attaches to a garden hose at one end and is sealed at the other. It minimizes evaporation and applies uniform coverage, but it must be moved frequently to prevent percolation losses. One approach to using soaker hoses for irrigation is to purchase enough soaker hose to have one hose per row. Each hose is hooked up to a manifold system. By leaving soaker hoses in place after crop establishment, the entire area can be mulched to further conserve water. A downside is that these hoses are expensive and often do not last very long.

Drip or trickle irrigation, when properly installed and operated, is one of the best methods to water a garden. Drip irrigation reduces evaporation and percolation to a minimum. Drip irrigation is the controlled application of water at a low flow rate and a prolonged period of time. It differs from conventional watering systems since the soil does not become over-saturated with water. When the rate of drip irrigation is adjusted correctly, no puddles of water form and none runs off. Several drip systems are available in garden centers that are easily adapted to any garden size and situation. The most common system uses drip-tape, which has holes in plastic tubes, allowing small amounts of water to be emitted. The drip-tape is placed along the row, so the root zone is moistened by the dripping water. The emitters are built into the tubing at varying intervals (12, 18 and 24 inches) to accommodate various soil types and crop spacing.

Pre-irrigate with drip irrigation to ensure adequate moisture when the garden is planted; apply at least 2 inches of water to the planting zone before seeding or transplanting (pre-irrigation).

Make sure the soil is firm at pre-irrigation time, so water will move laterally and downward in the soil. In many cases, the entire garden may need to be sprinkled to settle the soil for horizontal water movement, preventing movement straight down into the rows. This is especially necessary in sandy soils.

Deciding the amount of time to drip irrigate is a critical question. The gardener should strive to maintain the soil at field capacity, meaning soil is moist, but not saturated. A general recommendation is to operate the drip system for three hours per day, on alternating days. When rainfall is adequate, it is not necessary to water for several days. Table 4.15 is a starting place for those beginning to use drip irrigation.

Watering

- Adjust the flow or rate of water application to about ½ inch per hour. A faster flow will cause runoff, unless the soil has exceptional drainage. To determine the flow rate of a sprinkler system, place small tin cans at various places within the sprinkler's reach, and check the water level in the cans at 15-minute intervals.
- When using oscillating lawn sprinklers, place the sprinkler on a platform higher than the crop to prevent water from being blocked by plant leaves. Keep the water pattern even by moving

the sprinkler often, overlapping about one-half of each pattern.

- Avoid wetting the leaves of plants in late afternoon or evening. It is best to water in the morning. Wet foliage at night encourages disease.
- Place perforated plastic hoses or soaker hoses along one side of the crop row or under mulch. This allows water to slowly seep into the soil.
- Add enough water to soak the soil to a depth of about 6 inches. It takes about 2/3 gallon of water for each square foot, or about 65 to 130 gallons for 100 square feet of garden area. However, this amount varies according to soil type. Frequent, light watering encourages shallow rooting and causes plants to suffer more during drought, especially if mulch isn't used. Conversely, excess water can also be damaging to plant growth, especially in poorly drained soils. It also may cause fertilizer to leach away.
- To avoid wasting water, know the critical watering periods for selected vegetable types. This is particularly important where water is limited. In general, adequate water is most critical during the first few weeks of development, immediately after transplanting and during flowering and fruiting.
- When buying seed or plants for areas prone to repeated drought, choose drought resistant varieties.

Table 4.15. Drip irrigation scheduling for vegetable gardens.

Growth stage	1st Quarter		2nd Quarter		3rd & 4th Quarters	
	Below 90 F	Above 90 F	Below 90 F	Above 90 F	Below 90 F	Above 90 F
Air temperature	Below 90 F	Above 90 F	Below 90 F	Above 90 F	Below 90 F	Above 90 F
Soil texture	Run time in minutes/ days between watering		Run time in minutes/ days between watering		Run time in minutes/ days between watering	
Sandy or coarse	95 min. 3 days	80 min. 2 days	65 min. 1 day	80 min. 1 day	80 min. 1 day	100 min. 1 day
Loamy or fine	190 min. 6 days	195 min. 5 days	190 min. 3 days	160 min. 2 days	165 min. 2 days	100 min. 1 day

Note: Other methods for determining when to water can include pan evaporation, tensiometers, and using an evapotranspiration website at: http://agweather.mesonet.org/index.php/data/section/soil_water.

Note: Drip should be thought of as applying small amounts of water on a very regular basis, meaning don't wait until the soil water is depleted and the plants are drought stressed before applying water. During hot weather, it is likely you will be watering every day.

Weed Control

Weeds are plant species not welcome in the garden, and may or may not be preferred in other situations. Weeds compete with vegetables for water, light and nutrients and often harbor insect, disease, and nematode problems, causing damage to vegetables and greatly reducing productivity.

Mulching, hoeing and hand weeding are methods used to control most weeds in the garden. Proper soil preparation, adequate control of weeds before planting and planting crops when the soil is warm enough for optimum germination are good cultural practices and reduces the labor needed for weed control. If there is ample space for gardening, leave some space between rows for cultivating equipment.

Cultivation should be done when weeds are small and pose less of a threat to desired crops. Large weeds are more difficult to remove without damaging the crop. Cultivation may consist of rototilling, hand and tractor cultivators and hand hoeing. All tillage should be shallow, so roots are not injured. Hand weeding within the crop is usually necessary. Other cultural methods for weed control include:

- Crop selection – pick a crop and growing season where the plant will emerge rapidly, shade the soil and prevent weed seed germination.
- Close spacing of vegetable crops can inhibit weed growth when the leaves overlap at maturity. In a raised bed, keep this in mind for spacing plants.
- Mulches of either organic (clean straw or hay, paper) or synthetic (plastic) will shade the soil surface, controlling most annual weed species.
- The best weed control in the home garden is a sharp hoe and good mulch.
- Sanitation of the garden at the end of the season is critical. Remove and destroy remaining weeds and their seed heads.
- Cover crops are ideal to shade out weeds, even Bermuda grass. Bermuda grass can be shaded and discouraged by the dense canopy of a cover crop such as sudangrass, sorghum or buckwheat. Establishing a cover crop regimen early can help with the success of shading out competitive weeds. Winter cover crops can prevent soil erosion, runoff and cool-season weed establishment, while adding valuable organic matter.

Herbicides can be used for garden weed control. However, chemical weed control in the home garden is difficult because of the diversity of crops grown in the garden. A few basic questions to be answered before a gardener decides to use herbicides are: Does the gardener have the knowledge and equipment to properly apply the herbicide? Is there a labeled herbicide available to control the weed species in the garden? How much flexibility in crop selection is the gardener willing to sacrifice to utilize herbicides for weed control?

Types of herbicides include pre-emergence and post-emergence types. Pre-emergence types are sprayed or applied on weed-free soil before weeds emerge. These types control weeds by not allowing the seeds to germinate and emerge. Post-emergence types are sprayed directly on existing weeds and are often not selective regarding what plants are killed. Post-emergence herbicides, like glyphosate and sethoxydim, are useful choices when eliminating perennial weeds, such as Bermuda grass or Johnsongrass from future and existing garden sites. Visit the local county Extension office for information on current post-emergence and pre-emergence herbicides. **With any pesticide, read and follow label instructions.** Following the label will ensure the applicator knows how to use the herbicide safely for all concerned.

Mulching Garden Soils

Mulching garden soils may be one of the most valuable cultural practices of gardening. The use of organic materials for mulches can provide many beneficial effects. These include:

- prevention of annual grasses and weeds
- elimination of the need for cultivation and the resulting damage to plant roots
- reduction of moisture evaporation
- increase of water absorption and retention
- decrease in runoff and soil erosion
- regulation of soil temperature (see Figures 4.10 and 4.11).

Other benefits are:

- cleaner, more easily harvested crops
- reduction of fruit rot
- easier movement through the garden during wet periods.

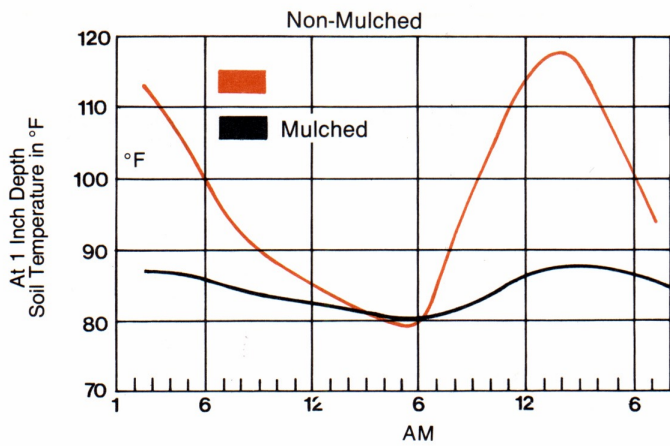

Figure 4.10. Mid-summer soil temperature differences at a 1-inch depth.

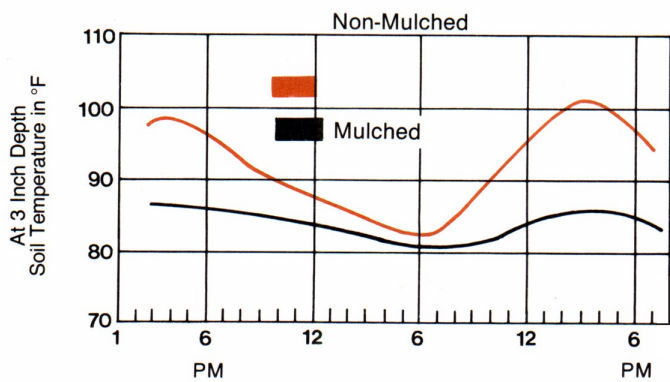

Figure 4.11. Mid-summer soil temperature differences at a 3-inch depth.

Mulch provides conditions for plant roots to develop throughout the soil and absorb water, nutrients and oxygen. Luxurious stem, leaf, flower and fruit growth follows the development of vigorous, extensive root growth.

Most Oklahoma soils are low in organic matter. The use of organic mulches in the home garden and their incorporation into the soil provides an opportunity to increase soil organic matter content, improve the physical condition of the soil and add some nutrients.

Mulching Materials

Many materials are available for mulching including clear, white or black plastic, landscape fabric, organic matter such as leaves, compost, newsprint, hay, straw and cottonseed hulls. The selection of a particular material depends upon the cost, purpose, availability of products, season

of the year, the crop to be mulched and the benefits and shortcomings of the mulch.

Plastic films

Clear plastic warms the soil more than other mulches, but it will stimulate weed seed germination and growth as well. It can be laid over rows to stimulate vegetable seed germination during cool weather, but must be removed promptly after seedlings emerge. Black plastic warms the soil during the cool season better than organic mulches and greatly reduces weed populations. However, black plastic does not control nutsedge. Make certain soil has adequate moisture when the plastic film is applied over the bed. Then cut holes through the plastic to allow for seeding or transplanting. Water can be applied under the plastic mulch with drip tape or soaker hose. If sprinklers are used, cut T-slits in the plastic to allow the water to penetrate.

Organic mulches

Organic mulches are some of the most commonly used mulches and the best for increasing organic matter in a soil. Typical examples are bark chips, compost, ground corncobs, chopped cornstalks, cottonseed hulls, grass clippings, leaves, composted manure, newsprint, peanut shells, peat moss, pine needles, sawdust, straw and wood shavings. Organic mulches are most useful in conserving soil moisture and reducing the soil temperature by 8 F to 10 F during the summer. For this reason, they should not be applied to cold garden soils. The soil will warm up very slowly and plant establishment will be delayed. On the other hand, organic mulches can reduce soil crusting. After the soil warms in the spring, organic mulches can be applied in a 2- to 4-inch layer around well established plants. Be sure adequate moisture is available before applying mulch. Mulches such as sawdust, wood shavings and corncobs have high carbon to nitrogen ratios and can use up nitrogen as they decompose; to compensate, increase the amount of fertilizer by about one-fourth. If excess amounts of these mulches are applied, it may prevent growth of vegetables until the mulch has decayed.

Suitable organic mulch materials should not contain herbicide residues, viable weed seeds, harmful disease organisms or pests. The material should be easy to apply and effective for at least one season. Mulch should not pack. The mulch

may be incorporated with the soil for further decomposition at the end of the season. It is a good practice to incorporate or compost garden debris at the close of the gardening season. This eliminates protective quarters for insects to use in winter months and rids the area of any disease-harboring plant material.

Crops that benefit from organic mulches include: tomato, pepper, eggplant, okra, green beans, cucumbers, cantaloupe, squash, broccoli, cabbage, cauliflower, Brussels sprouts, sweet corn, asparagus and rhubarb.

Other mulching materials

The use of aluminum foils, laminates and other types of synthetic mulching films may provide similar effects in regard to reduced soil temperatures and weed control. Also, certain kinds of insects (leaf hopper, spider mites and aphids) may be repelled, depending on the intensity of reflected light to the underside of the plant foliage.

Fall Gardening

Some of the best quality vegetables in Oklahoma are produced during the fall season when warm, sunny days are followed by cool, humid nights. Under these climatic conditions, plant metabolism is low; therefore, more of the carbohydrates manufactured by the plant are available to become a high-quality vegetable product. Vegetables grown in the fall not only provide fresh produce for the season, but several of the cold-tolerant types can be stored in the garden during winter months to be harvested as needed.

Successful fall gardening begins much earlier than the fall season. Factors to be considered are adequate soil preparation, available garden space, which crops will be grown, space for each crop, varieties to use and obtaining the quantity and varieties of seed. Some crops are more easily grown using transplants.

Warm season vegetables carried over. To some extent, the selection of crops will be influenced by what is presently producing well in the garden, family preference, space, water available for irrigation and crops adapted for fall production. Some crops planted in spring that may continue into fall include tomato, okra, pepper, sweet potato, cowpea and New Zealand spinach. These plants may produce excellent yields later in the fall season if

given proper care. If tomato, okra, or New Zealand spinach plants are too large for the space, prune them to reduce size and stimulate growth. If cultivation is used, it should be done very shallowly. These plants should also be fertilized, watered and mulched.

Cool-season vegetables including the heading brassicas (cabbage, broccoli, cauliflower), leafy greens (collard, kale, turnip, mustard, spinach, Swiss chard), root vegetables (turnip, parsnip, carrot) and many others do well in fall gardens. In addition to being cold tolerant, many of these vegetables are nutritional super stars, adding lots of vitamins, minerals and fiber to our diets. Several can be left in the garden during winter months, awaiting harvest.

Some fall vegetables are best established by using transplants. Those responding most favorably include broccoli, cauliflower, Chinese cabbage, leaf lettuce, Brussels sprouts, and cabbage. Transplants are most easily grown by planting seeds in a small flat, moving seedlings to individual containers for one month, then transplanting them to the garden. Growing transplants can be done under partial shade with insect protection following germination. To achieve maximum germination of lettuce seed, the planted and watered flat should be kept cool. This can be accomplished by placing the flat in a cool (60 F to 70 F) location for four or five days, at which time seed may begin germinating. The seedlings should be transplanted to individual containers within two to three days.

Usually, the time of planting is dependent upon the length of time required to produce the crop. Some crops may be limited to a specific planting date. Others, such as radish, may produce a crop in 20 to 30 days, allowing the gardener to make successive plantings for a more continuous supply. Cold tolerant crops planted in cold frames and under row covers make it possible to grow year-round in Oklahoma. Salad crops and leafy greens are particularly successful if grown using protective structures, and can be harvested as needed throughout the winter.

Since seeds and transplants may be planted in the garden during June, July, August and September, supplemental water is necessary to aid seed germination and plant growth. Many gardeners have a limited supply of water available, so drip irrigation applied only in the row may provide for suitable early growth.

Climatic conditions in July and August include high soil temperature, high light intensity and rapid drying of the soil. This increases the difficulties in obtaining a uniform stand of plants and may require special efforts. These might include shading rows immediately after seeding and supplemental water to reduce soil temperature and aid in germination. For viable seed to germinate, it must have the proper temperature, adequate moisture and sufficient oxygen. The surface of the soil, when exposed to the summer sun, will likely be very hot (140 F or 60 C). Vegetable seeds should be planted no deeper than three times the diameter of the seed. With small seed such as carrot, this would be no more than 1/4 inch deep. At this depth and exposed in the hot soil, death of the seed due to high temperature is likely. When hot soil is watered, it is likely to dry out quickly. Unless soil moisture is maintained at the depth where the seeds have been planted, germination will not take place.

To achieve proper temperature and adequate moisture, apply mulch over the row following planting and watering. Materials, such as screen wire strips, shade cloth or boards may also be used. This will moderate soil temperature and soil moisture. Remove cover after seedlings emerge. Another desirable practice is dig into the soil deeper than in spring planting. The seeds are planted in this furrow, covered and watered. In this manner, only the narrow trench would receive water, conserving a limited water supply. Later, cultivate along the sides of the row and fill soil to the same level as the rest of the garden. In this technique, small grass and weed plants would be covered (Figure 4.12).

Conditions favoring the germination of planted vegetable seed and lush growth also favor weed growth. Mulch the soil, or cultivate, when grass and weed plants are small and easily destroyed. Weed control in fall gardens is more critical than in spring.

Insect pests can come into the fall garden and seriously damage plants within a week, particularly during the early season. Frequent checks and immediate protective measures must be used. For control to be effective, determine what kinds of pests are causing damage.

Fall gardening summary

- Start early, whether carrying over a warm-season garden into fall or starting new cool-season plantings.
- Leftover seeds from spring planting may be used in fall planting. Always store seed in a cool, dry location such as a refrigerator or freezer.
- Several direct seeded, cool-season vegetables can be planted following the first cool front in August or early September
- To get plants established early, supplemental irrigation is needed. Drip irrigation is efficient and does not compact soil like overhead irrigation, allowing easier stand establishment.
- To conserve water, only irrigate furrows or rows. Wait for rainfall for general watering.
- Soak seeds overnight for planting (except beans and peas). This will hasten seedling emergence when moisture management is most critical to plant growth.
- Cover seeded rows to reduce soil temperature and drying.

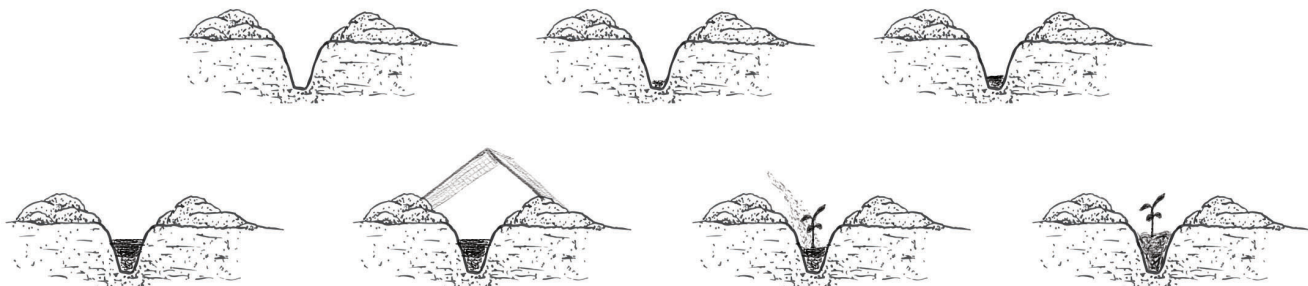

Figure 4.12. Planting schemes for hot weather.



Figure 4.13. Fall garden scene.

Extending the Growing Season

While the traditional garden is limited to spring through fall, ways have been found to extend the season. This is achieved by modifying the environment to protect plants from extreme heat and cold, winds, winter precipitation and insect pests. By using these season-extending techniques, gardeners can harvest greens and other cool-season crops into the winter months. In addition, gardeners can start warm season vegetables earlier in the spring and keep crops productive later into the fall months. There are many tricks to lengthen the growing season. Season extension depends on the individual gardener's knowledge, availability of supplies and investment of time.

Season extension involves providing favorable plant growth conditions on a day-to-day basis. It also protects plants from brief events causing serious plant damage, such as late spring or early fall freezes. Primary methods used for season extension are shown in Table 4.16. The greenhouse effect provides warm growing conditions during cool times of the year. In the same way a car warms up inside when sunlight shines on the windows, plants can be placed within transparent structures during cool weather and warmed during daylight hours. With proper design and attention, season extension can be used for plant growth not possible outdoors. During the evening, the same structure helps retain heat and protects plants from temperatures too cold for survival. During the summer months, it is often too hot for vegetables. Using proper watering practices and providing afternoon

shade can help keep plants healthy. Plants can be injured by wind, blowing sand, heavy rainfall and insect attacks. Row covers that allow light transmission can protect plants from a diverse array of adverse conditions that could end the gardening season too early.

The importance of air temperature for gardening is well recognized, but it is easy to overlook the need for adequate soil temperatures. Cool-season crops, like onions and lettuce, will benefit from practices to help warm the soil. For early planting of warm-season crops, like tomato and melons, it is necessary to warm the soil quickly to achieve optimal plant growth. Black plastic mulches and landscape fabrics are commonly used for soil warming in early spring. Additional benefits of mulches include prevention of weeds, moisture conservation, produce cleanliness and reduced plant diseases. White mulches provide some of these benefits without soil warming; a good choice for plantings done after May. Mulches should be tightly installed over a level, uniform soil surface so little air space is present. Drip irrigation is often installed before the mulch is applied.

These season-extension methods make use of the greenhouse effect to create growing environments more favorable than outdoor conditions. In addition to overall enhancement of growing conditions, these methods also help protect from short-term freezes, frosts, wind, hail and heavy precipitation. Because heat can be excessive, ventilation is required for cooling. Vents used for cooling high tunnels include roll up sidewalls, roof vents and end wall doors. As structure size increases, the potential for heat accumulation and a need for venting is required. Careful planning is needed to ensure high- or low-tunnel designs allow for adequate heating. Plastics designed for use as low tunnels may be purchased with openings allowing hot air to vent through the top. Cold frames should be designed for easy opening to allow for air circulation (Figure 4.14).

While cold frames use solar energy to warm the growing environment, additional soil heating increases versatility by creating a hot bed. This is accomplished using electrical heating cables buried in the soil, steam-carrying pipes or by the burial of fresh, straw-filled manure beneath the root zone of plants. Manure will generate heat as it decomposes. When solar energy is not available hot beds can result in more favorable soil temperatures and

Table 4.16. Season extension methods.

<i>Method</i>	<i>Purposes</i>	<i>Comments</i>
Cloches, Wall-O-Water, inverted jars, hotcaps, Dutch light portable mini greenhouse.	Modify the environment for individual or groups of plants.	Create warmer growing conditions and protect from brief cold exposure. Use non-vented or opaque designs for brief periods.
Covering of soil surface with plastic mulch and landscape fabrics.	Black and clear mulches warm soil. White mulch cools soil during mid-summer.	Black colors help with early warm-season crop plantings and suppress weed growth. White mulch prevents weeds, conserves moisture and helps cool soil.
Transparent row covers or low tunnels. Fabric row covers suspended over crops.	Modify the environment for rows of plants. Protect from wind and precipitation and exclude insect pests.	Clear polyethylene or other sheeting is placed over plants in the garden. Supported by wire or plastic hoops. Vented plastic available to prevent excessively high temperatures.
Cold frames	Structures outside the garden where plants may be placed for temperature modification and protection from rain, snow and ice.	Used to force spring-flowering bulbs, harden transplants, start cold tolerant transplants, overwinter semi-hardy plants, etc. May be constructed with recycled window sash or polyethylene attached to a frame.
Hot beds - cold frames with heat source below soil.	Starting transplants in late winter and early spring and growing cool season crops year round.	Heat sources include electric, steam and composting organic material below soil.
High tunnels or hoop houses	Provide enhanced growing environment and protection from brief adverse conditions such as frosts, late freezes, hail, wind and heavy rain.	Starting warm-season crops earlier in the spring to achieve earlier harvest. Extend harvest in the fall by protecting from first frost and freeze events. Cool-season crop productivity and quality are enhanced throughout the growing period. Many options for structure designs and expense.
Greenhouse	Enable growing throughout the year depending on heating, cooling and extra lighting used.	Many options for structures and supplemental equipment. Examples of production uses include bedding and vegetable transplants, winter production of tomatoes, lettuce, etc.



Figure 4.14. Cold frames for season extension.

increased air temperature than cold frames. For a manure-heated bed, remove 2 feet of soil (for better drainage, remove more soil). Add an 18-inch layer of straw-filled horse manure, then cover with 6 inches of good soil. For an electric-heated bed, remove 8 or 9 inches of soil. Place thermostatically-controlled electric cable in 6- to 8-inch loops on the soil, evenly spacing the cable, but not allowing it to cross itself. Cover the cable with 2 inches of sand or soil, then place hardware cloth on top to protect the cable. Finally, cover this with 4 to 6 inches of good soil.

While season-extension techniques help increase temperatures, keep in mind light is also a limiting factor during cool months. In winter, solar light intensity is low and days are short. Therefore, it is important to locate structures to receive as much light as possible. Locate permanent structures so they are not shaded by buildings or evergreen trees and shrubs. While they should not be too close, deciduous trees providing afternoon shade may be helpful to reduce the heat load as weather warms. Deciduous trees will lack leaves during winter months, so sunlight will penetrate. For maximum solar absorption, the ideal location for a cold-frame is with a slight slope and a south or southeastern exposure. Protection against winter winds is helpful, as is sinking the frame into the ground slightly, to allow the earth to provide insulation. Some cold-frames are lightweight enough to be moved where needed. The Dutch light is an example of a portable, greenhouse-like structure (Figure 4.15).

Structures ranging from small portable types to walk-in, permanent designs can be built from prefabricated kits or scratch. Cold frames are often built using wood and cinder blocks. The dimen-

sions may depend on the amount of space available or needed, intended use, the size of the window sash to be used and workers who will use it. Design the structure for ease of planting, weeding and harvesting. Typically, 4 feet is the maximum width to comfortably reach across with access from both sides. The sash should be sloped southward for maximum sunlight exposure. Plan for easy opening of the upper end of the sash for venting; some kits include automatic ventilation features. Tunnel designs range from low types placed over plants to high types of a walk-in design. Sizes vary considerably, for example, 8 feet wide by 15 feet long to 20 feet wide by 40 feet long. As with cold frames, there are many prefabricated kits available as well as plans for build-it-yourself designs. An Internet search is a good place to start to determine the best choice for an individual situation.

The starting point for tunnel and cold frame growing is the collection of as much solar energy as possible. One way to do this is to trap heat, which will be released as the sun sets later in the day. Barrels painted black and filled with water can serve this purpose by absorbing heat during the day and releasing it at night. The solar pod (Figure 4.16) works on this principle. Cold frame designs using insulation, with a high back and steep glass slope, also conserve heat. Movable insulation placed over cold frames protects plants during periods of low temperatures and low solar radiation.

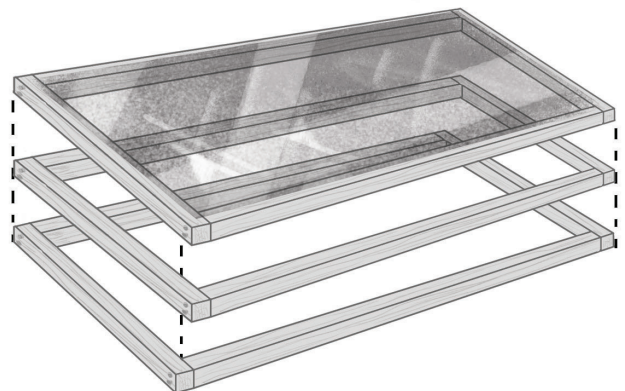

Figure 4.15. Dutch light, a portable, greenhouse-like structure.

Tunnels and cold frames can be used to get vegetable plants off to an early start or grow until it is time to harvest and prepare. For example, in Oklahoma, tunnels enable harvesting of tomatoes a month earlier than outdoors, can produce nutritious greens crops early throughout the winter and make for perfect quality vegetables. Excellent quality tomato, onion and cabbage plants can be grown in cold frames and readied for planting in a high tunnel or the open garden. Young seedlings of hardy and half-hardy annuals can be started in a frame weeks before it is possible outdoors. You can also sprout sweet potatoes for growing sweet potato slips. Exactly what a grower is able to do depends on their location and the type of structures available.

Sunlight heats the cold frame, but ventilation may be needed from late fall through early spring on clear, sunny days. Place a thermometer inside to monitor air temperature. Raising the sash will allow heated air to rise and exit the frame. Close the sash early in the afternoon to conserve heat for evening. Summer conditions may require sash removal, lathing over the sash or a combination of venting and the use of shade cloth. A cold frame can be converted to a hot bed by adding a heat source below the soil as discussed earlier.

The cloche was originally a bell-shaped glass jar set over delicate plants to protect them. Today, many types of portable structures that shelter plants from drying winds and cold air are called cloches. These structures are used to provide a protected microclimate for seed germination and

young plants, enabling early planting or extending the season with a fall garden. They are either placed over individual plants or can be tunnel-shaped to cover entire rows. Cloches trap solar radiation and reduce moisture evaporation. Simple forms are hot-caps and plastic jugs with the end removed. More elaborate types include fiberglass tunnels or row covers with ventilation openings for aeration, as well as glass panes connected by hinges to form a tent (Figure 4.17). There are a variety of forms on the market, and homemade designs are also an option. It is preferable to have a design that can be completely closed at night to prevent frost damage and opened or removed during the day for air circulation. Cloches should be anchored in place or heavy enough to not blow away.

Greenhouses enable growing year-round, depending on the heating, cooling and supplemental lighting used. An abundant selection of greenhouse designs is available on the market. Gardeners who intend to buy or build a greenhouse should investigate the options thoroughly, and visit with greenhouse owners to get suggestions. Greenhouses are a sizeable investment, so it is imperative to think it through carefully. Begin by making a list of purposes for the greenhouse; what will be grown; when will it be grown; how much will be grown; will supplemental heat, light or ventilation be needed; and what temperature is need for the crop? Compare house designs and construction material alternatives. Many companies provide specifications and descriptions of greenhouses they offer. Look in gardening magazines for advertisements and suggestions.



Figure 4.16. Heat trap container.



Figure 4.17. A Wall-o-Water is a product similar to a cloche.

The conservation-minded gardener may find an attached solar greenhouse desirable, even though the initial cost may be higher than a simple, freestanding, uninsulated greenhouse. For maximum effectiveness and lower heating costs, insulate the north and side walls. Leave a liberal amount of glass area for winter sunlight absorption on the southern side. Many houses use a double layer of ultraviolet, light, stabilized polyethylene. A small fan is used to create a small amount of pressure, separating the polyethylene layers, insulating the house.

Season extension often pertains to warming of the growing environment during cool weather. However, summer solar radiation intensity in Oklahoma is excessive for some vegetables and it may be difficult to start seeds or grow transplants. Insect pests, such as squash bugs and grasshoppers, can make it impossible to start certain vegetables, which shorten the harvest season. Row covers using shade cloths and fine netting for insects can help alleviate such problems. Dark color shade cloths reduce sunlight intensity and can be placed on frames over rows after planting.

Row covers are lightweight blankets made of spun-bonded polyester or polypropylene. Heavier weight thicknesses are used for protection from cold, while lighter weights are useful for insect exclusion, wind protection and short-term frost protection. Lighter weight materials do not produce heavy shading and can be left in place for prolonged periods of time without reducing plant growth.

Row cover materials come in rolls up to 30 feet wide and in various lengths. Row covers come in standard widths of 6 to 9 feet and are designed for beds 3 to 4 feet wide. Wider covers are needed for taller crops. Before installing a row cover, fertilize and plant the bed to be covered. The material may be used as floating row covers, in which the material is supported by the vegetable plants (Figure 4.18). Row covers can also be used by installing wire or plastic hoops, supporting the material above the crop plants. Row covers can be anchored by piling loose soil over the edges or by using special plastic or metal staples. The latter is a better choice in heavy soils. For vegetables requiring pollination, covers must be removed to allow pollinator access to the crop, such as the morning hours for honeybees.



Figure 4.18. Row covers.

Once the row cover is installed, plants can be watered directly through the row cover material or by drip irrigation installed prior to cover installation. Double layers can be used for added cold protection by placing one row cover over the other and anchoring both in place. Weeds will grow very well in the microclimate created under the row cover. To weed the covered plant beds, remove the staples from one side (the leeward side if there is a breeze). Reinstall the row cover and all the staples after pulling the weeds. To minimize the need to weed, lay plastic mulch under the row cover. Row covers may be reused if handled carefully. Store the cover in a sealed container, as the row covers can be a source of bedding for rodents.

Season extension summary

- Temperatures of the growing environment can be increased by using black color mulches to warm the soil and clear or translucent, enclosed structures to warm air.
- Use cold frames, low tunnels and cloches for cold protection when starting plants or for low-growing plants through harvest.
- High tunnels can improve the quality of cool-season crops through the normal season or to extend production through winter months.
- Warm season crops can be grown earlier in the spring and later in the fall using high tunnels.
- During warm periods, shade structures can reduce the impact of excess heat and sunlight on plants and maturing fruits.
- Suspended and floating row covers can be used to protect from winds, cold, insect attack and intense precipitation.

Diagnosis of Abiotic (Non-Disease) Vegetable Problems

Diagnosing growth, plant and fruiting problems is easier if the person making the diagnosis has experience and knowledge in gardening. Growth disorders of vegetable crops can be caused by various factors not related to insect or disease damage. Growth problems can be the result of a combination of interrelated factors. Correctly diagnosing the problem can only be determined if all factors are known.

Soil fertility, soil pH and other environmental factors can individually or collectively effect crop quality. Nutrient deficiencies and pH extremes in vegetable crops can reduce a plants ability to function normally. When these factors reach critical levels, symptoms of deficiency or toxicity are evident. Soil testing enables the gardener to supply the adequate amounts of nutrients to prevent problems. Plant nutrients required for normal growth are readily available at a slightly acidic soil pH: 6.2 to 6.8. Soil pH can be corrected by applying the proper soil amendment at the recommended rate prior to planting. This will prevent many nutrient deficiency problems.

Nutrient deficiency disorders

Nitrogen deficiencies affect the older, bottom-most leaves of the plant. Symptoms include light green leaves and slow or no growth of the crop.

Phosphorus deficiencies are expressed as stunting, intensified color, browning or purpling of foliage (lower leaves first) in some plants, loss of lower leaves, reduced flowering and weak root growth.

- Sweet corn will normally show a purple discoloration on the outer edge of the leaf blade. Phosphorus deficiency symptoms are common on early planted sweet corn growing in cold soil. If soil phosphorus levels are adequate, this condition usually corrects itself when soil warms up.
- Tomatoes will usually have purple veins on the underside of the leaves. This condition is often seen on recently transplanted, young, actively growing tomato plants. This condition usually corrects itself after new feeder roots are estab-

lished. Foliar application of water soluble fertilizer, such as Peters 20-20-20, should be made if the condition persists.

Potassium deficiency symptoms include reduced growth, shortened internodes, chlorosis and necrosis (death-browning) of leaf tissue, often at the margin on the older leaves of crops.

Magnesium deficiency: Low soil pH, combined with low levels of soil magnesium, can result in various foliage and fruit disorders. Symptoms include reduced growth, marginal or interveinal chlorosis on older leaves, cupped leaves and reduced seed production.

- Sweet corn will show a streaked leaf blade. The streaks are characterized by pale lines between the darker veins, running the full length of the leaf.
- Bell pepper will show a pale discoloration beginning at the leaf tip and spreading between the veins. Deficiencies develop soon after transplanting and result in stunted growth. Plants do not recover unless magnesium is applied soon after the deficiency develops.
- Tomato leaves have a blotchy appearance between the veins. Severe magnesium deficiency can cause marginal dieback of leaf tips. A calcium deficiency will produce similar discolorations, but is usually seen closer to the leaf tip.

Manganese: In very acid soils some microelements, such as manganese, are made more readily available for plant absorption. When this condition exists, plants can absorb the nutrient in excessive levels. At this point, the element becomes toxic to the plant. Symptoms of deficiency include interveinal chlorosis of young leaves followed by brown spots producing a checkered effect. Snap-bean foliage will appear bronze-colored and puckered.

Boron deficiency in vegetable crops will appear as internal defects of stems or fruits as they approach maturity, such as failure to set seed, breakdown of internal tissue and death of apical buds.

- Turnip roots will have a purple ring discoloration, usually close to the outer surface.
- Cauliflower heads can brown due to unavailable boron.

Physical Disorders

Molybdenum: If small, individual white spots are seen near the center of the fruit, then a molybdenum deficiency could be the culprit. It may also be expressed as interveinal chlorosis on older and midstem leaves and twisted leaves (whiptail).

- Tomato plants exhibiting a deficiency will have leaf blades more narrow than normal. A condition called white core occurs near the center of tomato fruit, causing a larger, whitened area than those caused by molybdenum deficiencies. White core is a physiological disorder and can be variety associated.

Calcium deficiency may result in inhibition of bud growth, death of root tips, cupping of maturing leaves, weak stems, blossom end rot of many fruits, pits on root vegetables and foliage may be an abnormal dark green. Blossom-end rot is a common disorder on tomatoes and other fruiting vegetables.

- Blossom-end rot is also found on bell pepper and watermelons. Low soil calcium and fluctuating soil moisture aggravates this situation. If soil acidity is too low, liming can help correct this problem. Spraying young plants with calcium chloride at a rate of 4 tablespoons per gallon of water will also help. Mulching and irrigating will aid in preventing this condition, which also is seen more on pruned tomato plants. Blossom-end rot can be very severe on oblong watermelon fruit, especially when plants are grown in acidic soil low in calcium. Calcium chloride sprays can help prevent this problem; use the same rates as those recommended for tomatoes.

Zinc deficiency is limited to specific soil-plant conditions or situations. Zinc deficiencies may cause distorted leaves, short internodes and interveinal chlorosis on younger leaves.

- Corn is the second most susceptible plant to zinc deficiency. Most soils in Oklahoma contain adequate amounts of zinc. However, the soil may show deficiency symptoms when soil pH is greater than 7.5 because zinc is unavailable to plants in high pH soils.

General condition causes: Physiological conditions can result in disorders of vegetables, especially as they approach maturity. Inadequate soil moisture for prolonged periods, followed by excessive water, can cause fruit cracking in tomatoes and watermelons. Mulching plants and timing irrigation to prevent moisture stress can prevent these problems.

Tomato problems: Physiological cracking of tomatoes is usually one of two types: vertical or radial. Vertical cracking (Figure 4.19) is called cat-facing, while cracking running around the shoulder of the tomato is called radial cracking (Figure 4.20). Both types can be influenced by variety and aggravated by unfavorable growing conditions. Uneven watering and severe pruning of the tomato plant can increase this condition on susceptible varieties.

Tomatoes can develop white rings just under the skin, which is caused by high temperatures. The only control is to keep the plant healthy to provide abundant foliage, which will shade the fruit.

Other fruit problems in tomato include blotchy ripening, yellow top, large-core with green-gel and sunburn. Tomato leaf roll (Figure 4.21) is fairly common and may or may not be associated with moisture stress, disease or nematode problems. If soil moisture is adequate and no disease or nem-



Figure 4.19. Vertical cracking also known as cat-facing of tomato fruit.



Figure 4.20. Radial cracking on tomato fruit.
 (Source of images - <http://pender.ces.ncsu.edu/2013/06/what-causes-tomatoes-to-crack/>)



Figure 4.21. Physiological leaf roll.
 (Image source - <http://www.uwex.edu/ces/ag/plantdoc/viewCase.cfm?cid=15352>)

atode problems exist, the leaf roll is an indication of an upcoming heavy fruit load. Leaf roll is more severe on heavily pruned plants.

Irish Potato problems: Hollow heart of Irish potatoes is a physiological condition occurring in susceptible varieties spaced too far apart. Plants experience slowed growth, followed by rapid expansion of the tubers brought about by excessive moisture and overfertilization.

Potato tubers, exposed to bright light, will turn green on the surface. This green color is due to

a chemical called solanin, which becomes more concentrated in the presence of bright light. This chemical will be found concentrated just under the potato skin. If these potatoes are to be eaten, it is recommended they be peeled deeply, cooked in boiling water and the cooking water discarded. Solanin is highly water soluble and most will be discarded in the water.

Cauliflower problems: Tight heads, of snow white color in cauliflower, result from excluding all sunlight. Tying wrapper leaves over the heads when they are the size of a quarter is usually necessary, even on the so called self-blanching varieties (Figure 4.22). Covering the heads

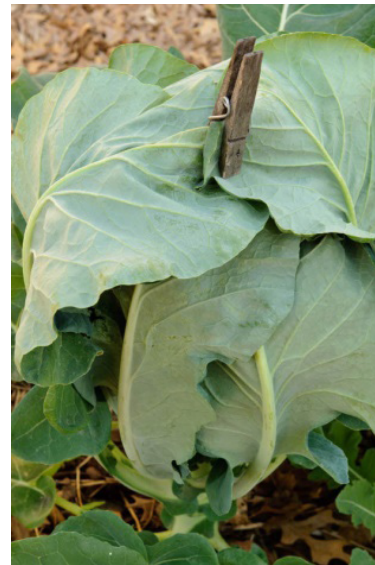

Figure 4.22. Leaves wrapped over cauliflower heads to induce blanching.



Figure 4.23. Loose, ricey brown heads when exposed to sunlight.

(Photos by Bruce Leander, source: <http://masterofhort.com/2013/08/fall-veggie-picks-cauliflower-by-patty-leander/>)

with older leaves helps make larger heads. Failure to exclude sunlight results in a loose, ricey curd, brown in color and off-flavor (Figure 4.23).

Pollination problems: Many crops require complete pollination of the female bloom to develop normal fruit. This is especially true with members of the cucumber and squash family. Pollination in the cucumber family is dependent on insects. Cucumbers and watermelon that develop into bottle shapes (Figure 4.24) are the result of incomplete pollination of the female bloom. Pumpkin blooms that do not pollinate completely will develop into pointed-ended fruit instead of round. Toma-



Figure 4.24. Cucumbers with a bottle shape.

(Image source - <http://extension.umd.edu/growit/pollination-problems-vegetables>)



Figure 4.25. Poor pollination can cause puffy or a lack of gel inside the fruit.

(Image source - <http://agdev.anr.udel.edu/weeklycropupdate/?tag=pollination>)

to blooms are self-pollinating, and do not require insects to transfer pollen for fruit set. Low temperatures (below 55 F) and high temperatures (above 90 F) can damage or kill pollen. Pollen killed by low or high temperatures will result in immature, cracked fruit on the blossom-end. Inadequate pollination in tomatoes can result in the seed cavity not being filled normally. This will result in puffy fruit (Figure 4.25).

Sweet corn pollination problems: Sweet corn is pollinated by wind. Lack of adequate pollen, high humidity, foggy mornings and excessive rain will result in poorly developed ears. A physiological condition sometimes occurs in sweet corn where juvenile corn ears are formed in the tassels. The reason for this condition is not well understood, but when the condition occurs, there seems to be little problem with proper pollination. During some seasons, sweet corn plants produce an excessive amount of suckers. These can be removed early in the season or left on the plant. There is no advantage in removal except to allow movement up and down the row.

Hail damage: Hail stones can cause severe crop damage, such as shredded leaves and immature tomato fruit that develop white bruised spots that remain white even after the fruit turns red. Wounds caused by hail damage of the aboveground portions of any crop provide conditions for plant diseases to develop, which may result in crop loss.

Wildlife damage: Rabbits, deer, feral hogs, moles, gophers and other animals can cause considerable damage to gardens. Some plants like soybeans and southern peas may recover if the tops are consumed after germination. Others may not recover. The best way to prevent damage from grazing animals is to fence the garden. There are many methods of fencing available. Sometimes, a simple chain link and t-post system can be used. However, check with the local county Extension office for the best option.

Table 4.17. Common garden problems.

<i>Symptoms</i>	<i>Possible Causes</i>	<i>Corrective Measures</i>
Seedlings die shortly after emergence	Soil-borne fungi	Plant good quality treated seed
	Planting in cold, wet soils	Plant in warm soil
Plants stunted in growth; yellow colored foliage.	Lack of soil fertility or soil pH abnormal	Use fertilizer and correct pH according to soil test.
	Plants growing in compacted, poorly drained soil	Modify soil with organic matter, coarse sand. Provide surface drainage.
	Insect or disease damage; Root Knot Nematode	Use recommended control treatments.
	Iron deficiency recommendations.	Apply iron or correct soil pH as per soil test
Plants stunted in growth; purplish colored leaf veins.	Low temperature	Plant at proper time. Do not use light-colored mulch too early in the season.
	Inadequate phosphorus recommendation.	Apply phosphorus as per soil test
Holes in leaves; leaves yellowish and drooping, or distorted in shape.	Damage by insects	Use recommended insecticide treatment.
Plant leaves with spots; dead, dried areas; or powdery or rusty areas.	Plant disease	Use resistant varieties, remove diseased plants when noticed and use recommended control treatments.
Plants wilt even though sufficient water is present.	Soluble salts too high	Soil test analysis.
	Poor drainage and aeration	Add compost or organic matter; ridge soil for surface drainage; plant in raised beds.
	Insect, disease or nematode damage on roots	Use recommended varieties and treatments of insecticides, fungicides and nematicides.
Plants tall, spindly, and unproductive.	Excessive shade	Relocate to sunny area. Remove weeds.
	Excessive nitrogen	Reduce applications of nitrogen.
Blossom drop (tomatoes).	Hot winds, dry soil	Use mulch and water. Plant heat tolerant varieties.
	Low night temperatures	Avoid early planting.
	Overwatering or disease	Reduce watering, use recommended disease control treatments.

Table 4.17. Common garden problems (cont'd).

<i>Symptoms</i>	<i>Possible Causes</i>	<i>Corrective Measures</i>
Tomato leaf roll.	Excess nitrogen and water Heat Beet Curly top disease	Withhold nitrogen, reduce watering. Remove plant if diseased.
Downward cupping and curling of tomato leaves.	Hormone herbicide (e.g. 2,4-D) damage	Don't spray on windy days or when temperature is above 80 F.
Leathery, dry, brown blemish on the blossom end of tomatoes, peppers and watermelons.	Blossom end rot	Maintain uniform soil moisture and apply mulch. Avoid overwatering and excessive nitrogen. Select tolerant varieties. Protect plants from winds during flowering and fruit set.
Broccoli flowers before the heads mature.	Poor growing conditions Planted too late in spring	Improve growing conditions. Plant earlier.
Cabbage heads split.	Heavy rains after heads almost mature plant can absorb.	Twist or pull the cabbage head to break some roots decreasing amount of water
Corn ears do not fill properly.	Poor pollination due to hot, dry weather; lack of wind Too much nitrogen; low potassium levels Insects feeding on silks	Plant in blocks of three to four rows rather than one long one. Adjust nutrient levels according to soil test recommendations. Use recommended insecticide treatment.
Bitter cucumbers	Older plants, low fertility, drought conditions, and high temperatures	Maintain adequate moisture, mulch the soil, and fertilize properly.
Cantaloupes with poor flavor.	Too much water during last week of vine growth, inadequate sunlight	Avoid watering plants just before harvest.
Poor fruit set of cucurbit crops.	Poor pollination	Vine crops produce male and female blossoms; male blossoms often form before female blossoms and drop without fruit set. Fruit set usually starts once female blossoms develop. Bees are needed to transfer pollen from male to female blossoms.

Disease and Nematode Control

Plant diseases adversely affect yield and quality of vegetable crops. For plant disease to develop, three things must be present: a susceptible host, favorable environment and disease-causing pathogen. This is referred to as the disease triangle. Disease-causing agents can be spread from plant to plant by wind, water, insects, contaminated seeds, transplants, infested soil and garden tools. Diseases of vegetables can be prevented by a combination of good management practices and sanitation (IPM). This control is obtained through the altering of either the host (i.e. a resistant variety, fungicide spray, etc.) or altering the environment (i.e. keeping garden crop foliage dry or preventing water and soil from splashing onto the crop) or by managing the garden to prevent the buildup of pathogens (i.e. crop rotation, sanitation, etc.).

Plant disease management tools

Certain vegetable varieties are resistant to one or more diseases, and the home gardener should take full advantage of this built-in protection. Remember, high quality seed and disease-free transplants are essential. Do not use plants showing abnormalities. Progress has been made in the development of good vegetable varieties with tolerance or resistance to several important diseases. Disease- and nematode-resistant varieties are available and should be used. A gardener may need to order seed to obtain resistant varieties from catalogs. Special requests at the local seed store also can be made. Refer to OSU Fact Sheet HLA-6032 *Vegetable Varieties for the Home Garden in Oklahoma* for a list of resistant vegetable varieties.

Tomato varieties: Varieties have been developed with resistance to: verticillium wilt, fusarium wilt, southern root-knot nematode, early blight and tobacco mosaic virus. Varieties with resistance to these diseases will be designated by the letters V, F, N, A and T. Where:

V = resistance to Verticillium wilt

F = resistance to Fusarium wilt

N = resistance to southern root-knot nematode

A = resistance to early blight

T = resistance to tobacco mosaic virus.

Some varieties may have the designation of F1, F2, F3, etc., which indicate the variety is resistant to race 1, 2 and 3 of the Fusarium wilt fungus.

There are many races of Fusarium wilt. If a garden site is infected with race 4 and a variety with resistance to race 3 is planted, there is a chance the tomato plant will become infected with Fusarium wilt. Resistance does not always mean immunity. This same principle is true with nematode resistance as well as some other diseases.

Cantaloupe varieties: Varieties are available with resistance to anthracnose, downy mildew, powdery mildew, Fusarium wilt and mosaic virus. Check with your local Extension educator or garden center for resistant cantaloupe varieties.

Cucumber varieties: Varieties are available with resistance to anthracnose, downy mildew, powdery mildew and mosaic virus. Check with your local Extension educator or garden center for resistant cucumber varieties. Note: it is a good management practice to select locally adapted varieties with disease resistance. In some cases, the resistance does not apply to the predominant race of the disease appearing in Oklahoma. For example, the resistance to powdery mildew can be to one or more races of the disease. Currently, race 1 is predominant in Oklahoma and a variety with resistance to PM 2, 3 and 5 may still become severely infected with the disease. "Mosaic" resistance refers to resistance to cucumber mosaic virus. Unfortunately there are other mosaic viruses that also attack cucumber, such as watermelon mosaic virus. Therefore, selecting a "mosaic" resistant variety may not prevent the infection of the plant by a virus disease.

Snap bean varieties: Varieties are available with resistance to bean mosaic virus, powdery mildew, halo blight and root rot. M = mosaic virus resistance, PM = powdery mildew resistance, HB = halo blight resistance, RR = root rot resistance.

Spinach varieties: Varieties are available with resistance to leaf blight, downy mildew, white rust and mosaic virus. (B = leaf blight resistance, BM = blue mold resistance, DM = downy mildew resistance (blue mold and downy mildew are the same disease), M = mosaic virus resistance.)

Watermelon varieties: Varieties are available with resistance to anthracnose and Fusarium wilt. There are no varieties with known resistance to downy mildew. Downy mildew is a serious disease of watermelon in Oklahoma. Note: there are several races of fusarium that attack watermelon.

Variety summary: Even with the best organic control methods, vegetables such as toma-

toes, cantaloupe, cucumbers, pumpkin, squash and watermelon are susceptible to many different foliar diseases. Preventing these diseases from destroying the crop requires a combination of several different crop protection methods. This includes crop rotation, garden sanitation, mulching, resistant varieties, irrigation management and fungicide applications to protect new growth and prevent defoliation.

Controlling nematodes

There are many species of nematodes and some, but not all, cause plant diseases. Control of root-knot nematode (microscopic eel worms) in the home garden can be difficult and frustrating. Home gardeners have few options for nematode treatment, since all nematicides and soil fumigants are for professional use only and require a permit. However, several more safe methods have been developed for use in home gardens.

Nematode control techniques:

- Incorporating green manure crops (small grains) to increase the organic matter content of the soil. Cereal rye is particularly effective.
- Chitin applications. University research has shown that the application of chitin will lower nematode numbers. See U.C. Davis "Floriculture and Ornamental Nurseries Nematodes" article at: <http://www.ipm.ucdavis.edu/PMG/r280200111.html>.
- Nematode-resistant varieties, especially for tomatoes.
- Garden site rotation is an excellent method of control, but not always a practical option.
- Crop rotation utilizing non-host crops such as corn and onions for root-knot nematode. Also, rotate the location of a crop within the garden yearly.
- Companion planting. Marigolds are not effective in reducing the number of root-knot nematode in the garden. Only varieties of the French marigold (Nemagold, Petite Blanc, Queen Sophia and Tangerine) have been shown to reduce nematode numbers. This reduction only occurs in the immediate root zone.
- Sanitation is important for nematode control. Roots of infested plants should be removed from the soil immediately after harvest. These infested roots should be destroyed, preferably by burning or burying in a landfill. Also avoid

moving nematode infested soil to non-infested sites. Check gardening implements and gardening equipment for soil before moving from one gardening site to the next. Washing the soil from implements, tools and equipment will help prevent the spread of root-knot nematode.

- Soil Solarization can reduce populations of nematode pests and requires no chemical application. It has proven to be effective for small garden areas. Soil solarization controls a wide variety of soil pests and is a technique commonly used in integrated pest management programs (Figure 4.26).

Note: No control method will eliminate nematodes from the garden soil. Some methods will reduce nematode numbers for a short period of time, but the nematode population may eventually rebuild.



Figure 4.27. Garden plot with soil solarization.

Fungicides

Seed treatments: The use of a protective fungicide will help protect seeds against seed rot and damping off in the early stages of seed germination and growth. Treating seed is one of the most efficient methods of controlling plant disease, using very small amounts of fungicide. Use pesticides according to directions on the label. Do not handle chemically treated seed with bare hands.

Protective fungicides for foliage: Fungicides are chemicals that control fungal diseases. Some fungicides contain copper, which may also provide some control of bacterial diseases. In general, fungicides are not toxic chemicals in regard

to human health. Fungicides labeled for use in the home garden are rated as slightly toxic (Caution signal word).

Various fungicides are available for foliage application and should be considered as protection against foliar diseases. They are primarily protectants. For the best performance, treat prior to infection, therefore a preventative spray program must be employed. Gardens with a history of foliar disease problems should begin applying foliar fungicides early in the growing season to prevent the early buildup of diseases.

Repeated applications are necessary. Most fungicides labeled for home gardens are not systemic in their action. New growth of leaves, stems and expanding fruit will not be protected from fungal infection unless the fungicide is applied directly to them. In order to protect new growth, repeated applications of fungicide is required often on a 7- to 14-day spray schedule. Infrequent fungicide applications are often ineffective in controlling foliar diseases. A gardener must be committed to repeated applications of fungicides, or no applications should be made.

Spray fungicides on all aboveground parts of the plant. Fungicide treatments for foliar diseases may be used on the following vegetables: pepper, eggplant, potato, tomato, watermelon, cucumber, muskmelon, squash and beans. Read and follow all label directions, especially the time interval between application and harvest. Fungicide applications should be based on weather conditions and other environmental factors favoring disease development. Gardeners must consider past disease problems, as experience will lead anticipation of disease problems to protect against. Before starting any kind of treatment, understand which disease protection is needed and use the appropriate fungicide for control.

Crop Rotation

Rotating where vegetables are planted is an excellent way to keep harmful soil organisms to a minimum. Experienced gardeners know the value of proper crop rotation, as the same crop planted in the same spot year after year decreases productivity. This is due to soil borne diseases, soil insects, nematodes and toxic crop residues building up through time. These detrimental factors decrease crop yields. Therefore, the location of vegetables must be rotated each season. Remember,

rotating the placement of each single vegetable is not enough. Rotations should be at a minimum every three years.

Each family of vegetables has a unique effect on the soil, and most vegetable varieties within a family are susceptible to the same diseases and insects. It is important to know which vegetables are in each plant family and plan rotations based on those. The most common backyard vegetables fall into nine distinct families.

Sanitation

Garden sanitation helps reduce the hazard of disease-causing microbes remaining from the previous crop. Plant debris may be plowed under in the fall or removed from the garden and thoroughly composted. Plant parts known to harbor disease should be removed from the garden and disposed of in the trash. Plant pathogenic microbes may survive composting. Plowing under plant residues in the fall hastens the decay of organic matter; however, non-diseased organic matter may be left to decay on top of the soil, benefitting the soil with rich nutrients.

Other disease control ideas

Non-chemical control: Diseases can be managed by mulching, sanitation, variety selection, choosing the right garden site, prudent use of fungicides and soil solarization. However, there are several other non-chemical procedures that can be used to reduce loss from some plant diseases. They include:

- Purchase disease-free seed and transplants.
- Avoid excessive soil moisture and irrigate using drip irrigation to reduce soil splashed onto crop foliage.
- If watering overhead, irrigate the garden early in the morning so the sun will quickly dry the leaves.
- Use mulch to protect the crop foliage from soil splash and regulate soil temperatures for maximum growth and productivity.
- Fertilize based on a soil test analysis.
- Space plants properly to allow for ample air circulation.
- Stake plants, such as tomatoes, to promote better air circulation and support the plant. This will shorten the time required to dry leaves after dew, rain and irrigation. Staking also lowers the humidity in the microenvironment,

thus reducing the conditions favoring disease development.

Insect Control

Many types of insects are found in the home garden. Identification is an important first step in pest control strategies. Harmful insects can be very destructive by feeding on plants and transmitting diseases. Conversely, beneficial insects can reduce the need for insecticide applications, and pollinators, such as honeybees, are needed to ensure proper pollination of many plants.

Scouting and controlling: The gardener must check plants regularly to detect the presence of injurious insects. Daily walks through the garden will help identify problems as they arise. This way, they may be controlled as soon as damage is evident. In this fashion, many garden insects can be controlled without the use of insecticides. Do not forget cultural (crop rotation, sanitation and solarization) and mechanical (hand-picking, traps and attractants, water pressure sprays and insect vacuums) controls are effective methods for controlling pests. Sufficient numbers of insects capable of causing damage should be present before control is initiated. Many species, like squash bugs, are easier to control while small and before populations reach damaging levels.

Insect damage and control: Some insects feed on the fruit and leaves, some bore into the plants, while others suck plant sap. No single cultural method or chemical will protect plants from all of these pests. Many insecticides are available today and should be selected with care and a specific pest in mind. Common insecticides for home garden use are available in synthetic-, botanical-, biological- and mineral-based formulations. Biological controls are another option, particularly for caterpillar pests. Other materials homeowners may use for insect control include diatomaceous earth, oils and soaps. A mixture of compatible insecticides can be used on most vegetables and will give excellent protection against many garden insect pests.

Soil insects: Prior to planting time, soil should be examined for insects. Insects that live in soil cannot be effectively controlled by treating the aboveground parts of plants. If soil insects are found in sufficient numbers, treat prior to planting with a recommended soil insecticide. A newly cul-

tivated area, which was previously a lawn or weedy area, may have high numbers of white grubs. White grubs and wireworms may cause serious damage to garden plants. Grasses and a variety of weeds serve as alternate hosts for grubs; thus, clean cultivation and good bed preparation is helpful to prevent damage by soil pests. If the garden area has a history of white grubs or wireworm problems, an insecticide should be broadcast and lightly tilled into the soil prior to planting. Routine treatments for soil insects are generally not recommended. Controlling soil insects after planting is usually not successful.

Stem-damaging insects confine their feeding activity to the stem of plants. When present, borers, cutworms and girdlers can be damaging to transplants. Cutworms include several insect species whose larvae chew plant stems at the soil surface, cutting them at ground level. Plants begin to wilt and usually die soon. In general, cutworm problems are sporadic, but occasionally can be severe. After transplanting, check daily for wilted plants with completely or partially severed stems. Watch for plants that wilt and do not respond to additional water. First, check for damage to the stem at the soil line (cutworms); if no damage to the stem is visible inspect the soil near the roots for grubs and wireworms. Perhaps the most effective method of controlling cutworms is to use collars around each new transplant (Figure 4.27). Collars should be removed two to four weeks from transplanting, so they do not interfere with normal plant growth. Remove weeds in and around the garden to help eliminate sources of additional cutworms. If an insecticide is used, effectiveness is increased by banding the insecticide at the base of the plant, preferably at dusk or shortly before.

Sucking insects feed on plants by sucking plant juices or chewing holes in the leaves. Aphids feed on a wide range of garden plants, causing them to wilt or distort. Sucking insects also produces honeydew, which can lead to sooty mold, an aesthetically displeasing fungal disease. True bugs have sucking mouthparts and can cause wilting and death of plants. Especially noteworthy are squash bugs, which are legendary pests on cucurbit crops. Leafhoppers are another sucking insect, along with spider mites, which damage plants by sucking plant juices. Spider mites may cause webbing or a bronzing cast to plant foliage. Leafhoppers are considered a major vector for



Figure 4.27. Toilet paper roll placed around young plant helps control cutworms.

several plant virus diseases.

Chewing insects: Beetles are chewing insects which damage plants by chewing numerous holes in the leaves. Flea beetles, cucumber beetle, blister beetle and Colorado potato beetles are common insects found in the garden. Caterpillars are also found in most gardens. Corn earworms, tomato fruit-worm and tomato hornworm are common examples. Grasshoppers can be especially troublesome, particularly during dry years.

Harvest problems: It is especially frustrating to have insects attack a plant as harvest approaches. Sweet corn, squash and tomatoes can be especially attractive to insects at this time. Some of the same pests that feed on foliage also feed on fruit, like corn earworm.

General references: References for insect management in home gardens includes:

- HLA-6431 - Earth Kind Gardening Series: Cultural Control Practices
- HLA-6432 - Earth Kind Gardening Series: Mechanical Pest Controls
- HLA-6433 - Earth Kind Gardening Series: Botanical Pest Controls
- HLA 6434 - Earth Kind Gardening Series: Biological Pest Controls

- EPP-7307 - Beneficial Insects
- EPP-7313 - Home Garden Insect Control
- EPP 7322 - Grasshopper Control in Gardens and Landscapes

Garden insecticides: There are several insecticides labeled for use in home gardens.

- Synthetic insecticides can be found in E 832 *Extension Agent's Handbook of Insect, Plant Disease, and Weed Control*
- Botanical insecticides include pyrethrins, Rotenone® and Neem®.
- Mineral-based insecticide that has been used by homeowners for years is sulfur.
- Microbial and Biological controls are becoming more popular; *Bacillus thuringiensis* (Bt) is a good example.
- Other materials homeowners may use for insect control include diatomaceous earth, oils, and soaps.
- Remember – insecticides are poisonous (even natural ones), so READ AND FOLLOW THE DIRECTIONS ON THE LABEL for their use, storage, disposal and pre-harvest intervals.

Organic Gardening Basics

What Is organic gardening? Through the years, various connotations have been attached to the term organic gardening. In fact, organic gardening combines methods and strategies for producing healthy plants based on a view of the garden, the surrounding landscape and the organisms they contain as an overall system. Organic gardening techniques are not new. The reliance on chemical fertilizers and pesticides are relatively new, dominating farm production practices since World War II.

The foundation of a successful organically-grown garden is the soil. Healthy soil contains soil particles, organic matter, water, air, micro-organisms and animals like insects and other arthropods. Incorporating organic matter into the soil using compost, composted bark, peat and other materials improves soil structure and also provides sources of micro-organisms (microbes). Microbes such as bacteria, fungi and tiny arthropods break down plant debris and other forms of organic matter, ward off pest organisms and after they are dead, decompose to provide a natural source of nutrition for plants. Eliot Coleman, an accomplished organic gardener and author, refers to this

combination of organic and inorganic materials as “living soil.”

Organic gardening is not a method of pest (disease, insect and weed) control. It also is not gardening without the use of pesticides. Pesticides are used selectively and only as a last resort.

Organic gardening generally may be more labor intensive, requires knowledge of ecological relationships between components of the garden and requires more planning. For these reasons, organic gardening techniques tend to lend themselves easier to smaller farms or home gardens. Larger producers are turning more often to practices used in organic farming such as soil building, managing pest resistance and managing their farms on the basis of ecological systems because of economic realities. Organic gardeners are usually willing to accept some plant damage, often superficial, for the sake of knowing what was put on their food and flowers.

Soil — the basis of organic gardening

Preventing soil compaction: Avoid walking on garden beds, particularly when the soil is wet. Water and oxygen can't move effectively through compacted soil and plant roots can't penetrate compacted soils efficiently. Planning the garden so walkways are conveniently placed for people and equipment will reduce the urge to take short cuts through beds.

Natural fertilizers: Organic gardeners use natural fertilizers like compost tea, fish and/or blood meal, animal and green manures and mineral elements to improve soil fertility. Minerals in their raw form make up part of the soil structure and improve fertility. Of the three main plant nutrients vegetables need, nitrogen is the only one that readily leaches in the soil. Many natural fertilizers slowly release nutrients to the plant through a longer period of time. On the other hand, synthetic fertilizers contain nutrients readily available to the plant, but do nothing to improve soil structure. When any fertilizer is overused or improperly applied, it can injure the crop and leach out of the soil, resulting in environmental problems.

Managing soil fertility: Before planting your garden, have a soil test done to know the soil pH and what amendments are necessary for plants to grow and produce. This requires a basic knowledge of plant nutrition and what materi-

als are natural sources of elements and minerals. For example, limestone can be added to increase soil pH. Phosphate rock is a slow release source of phosphorus. Greensand is a slow release source of potassium and trace elements from sea bottom deposits.

Green manure crops are cover crops that are tilled back into the soil rather than being harvested. Winter wheat, rye, crimson clover and Austrian winter peas are common fall-sown cover crops that grow during the winter season, then tilled back into the soil several weeks before planting. This practice prevents soil erosion and weed growth during the winter months or periods when beds are fallow, helps move nutrients from lower soil layers to upper layers, prevents nutrient loss in unprotected soil and the tilled-under plant material becomes a rich source of organic matter and plant nutrients in the soil. In addition, legume cover crops (clover and peas), when inoculated with the proper bacteria, can fix nitrogen from the atmosphere, making it available for garden crops to follow. Cover-cropping is as practical in large row crop situations as it is in a home garden containing raised beds and often is used as part of crop rotation cycles.

Plant diversity: In nature, plants are found in association with many other species of plants. There are no naturally occurring areas where a single type of plant is growing. Even in a pine forest or oak woods, a variety of plants in the understory can be found. Mono-cultured crops (an area planted to a single crop) are at greater risk of disease and insect pest problems simply because non-host plants are not present to help slow the spread of an infestation or infection. Pests have free range over an area that contains nothing but an ideal host plant for food or reproduction. Pest populations quickly increase with these conditions. Monocultures can also reduce soil fertility because all the plants are competing for the same levels of nutrients from the soil. For example, corn is a heavy nitrogen feeder. Continual nitrogen fertilizer amendments are required to maintain solid plantings of corn during its growing season, and if the area is planted with only corn year after year, naturally occurring sources of nitrogen in the soil are depleted quickly and nitrogen fertilizers become the sole source of nitrogen for the plants. For these reasons, organic gardeners emphasize diversity in their garden planning. Crop rotation, and diversified color, shape and odor of plants may help re-

duce insect pest problems because they may be unable to find a suitable plant host. Research findings about the effects of companion planting are not conclusive, but this is a time-honored method for reducing pest problems.

Crop rotation strategies: The strategy behind crop rotation is that two crops in succession will not use the same amounts of nutrients and will not be attractive to the same pest organisms. Plan crop rotations so plants in the same botanical family do not follow each other in rotation and are not planted near each other. For example, do not plant tomatoes, peppers or eggplant where potatoes were grown earlier in the season. These plants all belong to the Solanaceae family and are susceptible to the same disease and insect pests. Avoid planting a bed or row of peppers near tomatoes for the same reason.

Another benefit of crop rotation is you can follow one type of crop that uses high amounts of nutrients with another crop that can help replace the nutrients used by the first. Corn and beans in rotation is a good example of this strategy. Beans can fix nitrogen in the soil, making them a logical crop to plant after corn has been harvested. The “three sisters” concept, corn, beans and squash, have traditionally been planted together – the beans and squash crawling up and among the corn plants (Figure 4.28). Not only can the beans fix nitrogen in the soil as the corn uses it, but the close planting of all three crops reduces weed problems, making it more difficult for pests to invade and providing some physical support for the corn. Keeping records and a yearly map of the crop rotation provides the information needed to develop crop rotation plans.

Good management practices: Besides the emphasis on healthy soil and plant diversity, other cultural techniques used by organic gardeners are similar to those used by all types of gardeners. Techniques include:

- choosing resistant varieties when possible
- proper site selection and preparation, planting and care
- tilling to loosen soil
- adding soil amendments
- proper plant spacing to maintaining uniform soil moisture
- avoiding wounding of plants
- avoiding working around plants when they are wet



Figure 4.28. The “three sisters” planting concept includes corn, beans and squash.

- removing plant debris and diseased plant material as soon as possible
- supporting branches or fruit so they don’t rest on the ground
- using mulch
- paying attention to planting dates to avoid possible pest problems.

Pest Control Strategies in Organic Gardens: Plants grown in healthy soil are less likely to be attacked by pest organisms. Diseases and insect pests are attracted to weakened or stressed plants with impaired defense mechanisms. When healthy plants are infected or infested, they are more likely to withstand or outgrow any damage. Obviously, growing plants selected for pest resistance puts the plants and the gardener one step ahead of certain pest problems. Pest control is easier when the problem is diagnosed and treated as soon as possible – while the pest population is still small, or the pests are young. For this reason, regular and frequent scouting of the yard and garden is important to effectively suppress pest problems using organic gardening techniques.

Management of plant diseases: Reducing disease problems in any garden relies on preventive measures. As noted earlier, the “disease triangle” must be complete for infection to occur. The primary preventive strategies already mentioned include: resistant cultivars and good cultural practices. Certain soil-borne diseases, like southern

blight of Solanaceous crops, can be prevented by cultural means. To prevent southern blight, deep till to bury crop debris at least 4 to 6 inches deep. Also wrap aluminum foil around the base of each plant to prevent splashing soil from coming into contact with plant stems. Mulches protect plants against soil-borne pathogens disseminated by water splash. When plants in the organic garden do become diseased, control options include removing the infected part, if only a few leaves or stems are involved. The entire plant may need to be removed if the disease is due to a wilt or severe root rot infection. Use a natural chemical control. The active chemical ingredients in pesticides acceptable for use in organic gardens are from natural sources and do not have long residual effects (Table 4.18). They will decompose rapidly in the environment, except materials containing elements like copper. These materials are generally less toxic to humans and other animals than synthetic chemical pesticides.

Management of insect pests: The good management practices discussed earlier will go a long way toward preventing insect pests in the yard and garden. In addition, beneficial organisms can help suppress pest populations in the garden. These include beneficial insects, spiders, birds, bats, fungi and bacteria, which cause disease in arthropod pests. Organic gardeners encourage the activity of these beneficial animals and microorganisms by providing a habitat favorable for their growth and reproduction. Many excellent books and websites are available with photographs and descriptions of both the pest and beneficial insects and mites. It is essential to properly identify a potential pest to avoid killing beneficial insects! Permanent grass walkways or rocks provide shelter for ground beetles. Perennial flower beds will provide pollen and nectar sources for many beneficial wasps, and strip-plantings of plants like alfalfa, soybean, Queen Anne's lace or clover will attract many beneficials. Insects, birds and bats will appreciate access to water. Change water containers every few days to discourage mosquitoes. Purchasing beneficial mites and insects for release in the garden is not necessary and usually not effective. Augmenting naturally occurring populations of beneficials in the garden disrupts the balance of pests and beneficials. Beneficials usually disperse quickly when released into an area already supporting a natural population.

Controlling insect infestations: When infestations do occur, a number of management practices are acceptable in organic gardens. If the infestation is not too large, the best control option is hand picking the pests or knocking them from the plant into a container of soapy water. Learn to recognize egg masses of pests. Crush them or remove them with the part of the leaf where they are attached. A forceful stream of water to an infested area of a plant will knock off and kill many soft-bodied pests like aphids and mites. If a problem doesn't respond to these cultural and biological control practices, a number of botanical, microbial and mineral insecticides, along with insecticidal soaps and oil, are available to the organic grower. These are listed in Table 4.18. Use pesticides selectively, opting for pest specific materials first, like the various Bt formulations.

Weed Pests: Unless unavoidable, don't establish a garden in a heavily weed-infested area. Try to prepare a new seed bed at least three months prior to planting. This will allow enough time for weed seeds in the upper 2 to 3 inches of soil to germinate and be removed by light cultivation.

Methods of weed control: If the garden area is small, hand-hoeing can provide inexpensive effective weed control and provides good exercise. Hoe or pull weeds when they are small. It takes less effort and is more effective. Mulching was mentioned earlier as an effective method of controlling weeds. Organic mulches should be free of weed seeds, insects, diseases and chemicals. They should be applied at least 1/2 inch thick to the soil surface before weeds have time to emerge from the soil. Besides weed control, advantages for organic mulches include keeping soil cooler during the summer, conserving water and being able to work it into the soil as additional organic matter after a crop is finished. Sheets of black plastic can also be used as mulch. It is more costly however, and may block water from reaching the soil if an irrigation system is not in place under the plastic. One disadvantage to using plastic mulch is it cannot be tilled into the soil to decompose at the end of the growing season. A productive and attractive yard and garden maintained by organic practices may require more time, labor and interest in the natural processes ongoing in the environment, but most organic gardeners feel this is part of the satisfaction and enjoyment they derive from working with nature.

Table 4.18. Pesticide materials generally acceptable for use in organic gardens.*

<i>Active Ingredient</i>	<i>Activity</i>	<i>Helps control/prevent</i>
Avermectins	Insecticide	Fire ants, leafminers, spider mites
Azadirachtin (neem) – labeled for ornamental plants only	Insecticide	Aphids, moths, leafminers, caterpillars, thrips, whiteflies, beetles
<i>Bacillus papillae</i>	Insecticide	Japanese beetle grubs
<i>Bacillus thuringiensis</i> (BT)	Insecticide	Caterpillars, beetle larvae, fly larvae – depending on formulation
Bordeaux mix (lime-sulfur) May cause plant injury at high temperatures	Bactericide, fungicide	Leafspots, bacterial wilts, powdery mildew, rust, fire blight
Copper – toxic when used repeatedly	Bactericide, fungicide	Leafspots, black rot, downy mildew
Growth regulators	Insecticide	Fire ants, fungus gnats, fleas, mosquitoes
Insecticidal soaps and oils	Broad spectrum insecticide	Mites and soft-bodied insects, including scale
Pyrethrin	Broad spectrum insecticide	Aphids, cabbage loopers, codling moth, beetles, spider mites, stink bugs, thrips, whiteflies
Ryania	Broad spectrum insecticide	Thrips, corn earworm, European corn borer
Sabadilla	Insecticide	Aphids, caterpillars, grasshoppers, stink, squash, and tarnished plant bugs, loopers, leafhoppers, beetles, thrips
Streptomycin or Agromycin	Bactericide	Fire blight
Sulfur – toxic	Bactericide, fungicide	Apple scab, brown rot of peach, powdery mildew, leafspots, rusts

* Cautionary note: “Acceptable for use in organic gardens” does not mean these materials are not toxic or potentially harmful to the applicator or wildlife. These materials are pesticides. The applicator should always read and follow label directions on any pesticide material.

Herbs

Culinary herbs are plants grown for flavoring various kinds of foods. Mild savory herbs impart a delicate flavor to foods; the stronger or pungent herbs add zest. Many kinds are adapted to and grow successfully in Oklahoma gardens. Although some herbs are also used for medicinal purposes, this section deals mainly with those used in cooking. The plants, in many instances, are ornamental and interesting to grow as well.

Starting an herb garden: The general culture of herbs is quite similar to vegetables and flowers. Suitable soil, mulching, irrigation, plant spacing and insect control should be followed. With few exceptions, most herbs prefer average moisture, never one extreme or the other. In general, herbs need a sunny location – five hours or more of sun per day. If a spot with that much sun isn't available, try growing herbs that tolerate a shadier spot. Shade-loving herbs include angelica, cardamom, chervil, sweet cicely and violets. Shade-tolerant herbs include bee balm (monarda), catnip, coriander, lemon balm, mint and parsley (See Table 4.19). Experiment with other herbs to see if they will take a shadier spot, however most herbs of Mediterranean origin (such as lavender and rosemary) must have lots of sun. If interested in saving seed for the next season, choose one or two plants of each variety and allow them to bloom and go to seed. Harvest the seed heads when they change from green to brown or gray, and dry them thoroughly to ensure a good germination.

Herb pest control: Generally speaking, many herbs have few pest problems, particularly when grown in the right conditions (soil, moisture, light). If it is necessary to control insects or diseases the gardener must consider whether there is a labeled pesticide for control of the pest and follow all label instructions in regard to the specific herb crop being treated. Fact sheet EPP-7313 *Insect Control in the Vegetable Garden*, though not specific for herbs may provide cautions as well as recommended treatments.

Herb life cycles: Some are annuals, thus grown from seed with the knowledge that portions will be harvested at the appropriate time. Mature seeds may be harvested and used for plantings in future years. Others are biennials, which suggest the plant will grow and produce during two seasons. Seed production generally takes place

only during the second year of growth. With carrot and caraway, the usual flavoring substance used is the seed. With parsley, it is the foliage that is used. The seeds would be the products of the second growing season, while the best parsley foliage for flavoring would be produced the first season. Perennials will grow and produce several years from one planting. Perennial herbs are often started from cuttings of young plants. In several instances, seeds are not produced. The grower may use bulbs, roots, rhizomes or cuttings to propagate more plants. Perennial herbs should be planted in an area that will not be disturbed by tilling and can be included in landscape plantings. Those that spread by runners, such as the mints, should be given a large, isolated area or must be contained in some fashion (to a depth of 10 to 12 inches) to prevent them from taking over the garden. Some tender perennials need protection from winter winds; plant on an eastern exposure if possible. Evergreen trees and shrubs can be used to break the wind and create "microclimates" for the herbs. Rocks are often incorporated into the design of herb gardens to provide focal points and windbreaks, and to help keep roots cool and moist during the heat of summer.

Harvesting is best done in the morning, just after the dew has dried, but before the sun gets hot; the concentration of oils is highest at this point. Discontinue harvesting perennial herbs in late summer or fall. This will allow time for new growth to harden and gather carbohydrates in preparation for winter. However, small harvests can be made during most of the fall; sage flavor may actually be improved by two or three frosts prior to harvest. When harvesting for drying, it is often necessary to spray the plants with a garden hose the day before cutting to clean dirt and dust off the leaves. Harvest them the next morning after the leaves have dried.

Preparing for storage: Herb leaves used for flavoring are usually more flavorful when harvested at or just before blooming. In such instances, one may harvest portions of the stems with leaves, flowers, and/or flower buds attached. Hang the herbs in loosely tied bundles in a well-ventilated room. The branches may also be spread on a screen or cheesecloth. If only leaves are needed, they may be spread on flat trays. After thoroughly drying in locations with minimum sunlight to reduce the loss of color, materials may be stored in dark-

Table 4.19. Some culinary herbs for Oklahoma.

Common Name	Scientific Name	Preferred Propagation	Plant Spacing in Inches			Height	Parts Used*	Flavoring For**
			In Row	Between Rows	Rows			
Annuals								
Anise	<i>Pimpinella anisum</i>	Seed	6	12 to 18	18-24	S, L	B, S, M, Ms, Ga, Sa	
Basil	<i>Ocimum basilicum</i>	Seed	12	12 to 18	18-24	S, L	S, St, M, Sa, Ms	
Borage	<i>Borago officinalis</i>	Seed	12	18 to 24	18-28	L	G, Sa, P, S, St, V	
Coriander	<i>Coriandrum sativum</i>	Seed	12	18 to 24	24-30	S	B, S, M, Ga	
Dill	<i>Anethum graveolens</i>	Seed	12	18 to 24	30-36	S	P, Ms, M, Sa	
Fennel	<i>Foeniculum dulce</i>	Seed	12	18 to 24	24-36	S, L	S, Ga, B	
Garden cress	<i>Lepidium sativum</i>	Seed	3 to 6	12	6-12	L, Sp	Ga, Sa, M	
Nasturtium	<i>Tropaeolum minus & majus</i>	Seed	12	18 to 24	12-18	L, Sp	Sa, S, D, M, St	
Savory	<i>Satureja hortensis</i>	Seed	8 to 10	12 to 18	12-18	L	S, Sa, D, M	
Biennials								
Carrot	<i>Daucus carota</i>	Seed	3 to 4	12-18	18-24	S	S, St, B, V, P, M, G	
Caraway	<i>Carum carvi</i>	Seed	6 to 8	12-18	12-18	S, L	Ga, B, S, Sa, Ms	
Parsley	<i>fff</i>	Seed	6	12	8-16	L	Ga, S, Sa, St, V	
Perennials								
Chives	<i>Allium schoenoprasum</i>	Seed or Bulbs	6	12	8-16	L, B	S, Sa, M, B, Ms	
Garlic	<i>Allium sativum</i>	Bulbs or Bulbils	4 to 6	12 to 18	16-24	B	S, Sa, M, B, Ms	
Horseradish	<i>Amoracia rusticana</i>	Roots	8 to 12	12	16-24	R	Ms, P	
Lemon Balm	<i>Melissa officinalis</i>	Seed, Cuttings	12	12 to 18	18-24	L	S, M, St, Ms	
Mints	<i>Mentha</i> spp.	Rhizomes, Plants	6 to 8	12 to 18	18-24	L, Sp	Ga, Sa, M, Ms, P	
Oregano	<i>Origanum vulgare</i>	Cuttings, Divisions	8	12 to 18	18-24	L	S, M, St, Sa	
Rosemary	<i>Rosmarinus officinalis</i>	Seed, Cuttings	24	24 to 36	30-36	L	M, Ms, St, S, D	
Sage	<i>Salvia officinalis</i>	Seed, Cuttings	12 to 18	18 to 24	16-20	L	M, D, St	
Tarragon	<i>Artemisia dracunculus</i>	Cuttings, Divisions	12	18 to 24	18-24	L, Sp	Sa, Ms, V	
Thyme	<i>Thymus vulgaris</i>	Seed, Cuttings	12	12 to 18	8-12	L, Sp	S, Sa, D, B, V, Ms	

*Parts Used: B=Bulb; L=Leaves; R=Root; S=Seed; Sp=Sprig

**Flavoring For: B=Breads and Pastries; D=Dressings; G=Cooked Greens; Ga= Garnish; M=Meats; Ms=Meat Sauce; P=Pickles; S=Soups; Sa=Salads; St=Stews; V=Vegetables Originally prepared by W. R. Kays.

ened areas in airtight containers or in containers in the freezer. Choose ceramic jars or darkened glass containers to help protect the herbs against light deterioration. Make certain herb leaves are completely dry to prevent mold during storage. Label all storage containers with the herb name and date and store in a cool, dry place. Quick frozen herbs will keep up to two years in the freezer if well wrapped. Seal in airtight plastic bags and label with name of product and date. Dried herbs store well for up to one year. Their strength can be judged by their aroma. Dried herbs can be stored whole or crushed, but whole herbs retain their flavor longer.

Ground herbs: Many herbs are available commercially as dry rather finely ground or rubbed materials. For those who desire to grind or pulverize home processed materials, it is best to grind only small amounts rather than all as soon as dried. There may be a greater loss in aroma and flavor following prolonged storage after grinding.

Fresh and potted herbs: Some herbs are preferred as fresh material to be used as a garnish, so would not be collected for drying. Gradually remove some of the leaves as needed, but do not remove all the foliage at one time. With proper care, these plants will produce over a long period. Some herbs can be grown indoors during the winter. Place them in a sunny south-facing window and care for them like houseplants. Either dig up herbs toward the end of the growing season and place them in pots, or start from seed indoors. The herbs best adapted to pot culture are basil, chives, mint, parsley, sweet marjoram and rosemary.

Production Hints for Some Popular Home Garden Vegetables

Asparagus is a perennial vegetable requiring a permanent site in the home garden, so special attention must be made to site selection and preplant soil preparation. Preplant control of perennial weeds is particularly important, since they can be a serious on-going issue for asparagus. Also, soil testing, adding recommended fertilizers and amendments and addition of organic matter to the soil prior to deep soil tillage is key for having a productive asparagus bed.

Beans grow best in soil with a pH of 6.0 to 7.5. To reduce the risk of disease, do not plant them where any other beans have grown in the past three years. Inoculate the seed with the bacterial inoculants that enable bean roots to develop nodules that house the rhizobium which fix nitrogen from the atmosphere. Sow seeds 1 to 1 ½ inches deep. For bush beans, set seeds singly about 3 inches apart in rows about 2 feet apart. Plant pole beans about 2 feet apart in rows 3 feet apart. Plant four to six seeds, and after the plants have emerged, thin to the best three or four plants. If pole beans are grown along a fence, space seeds singly about 6 inches apart. When both bush and pole beans are about 6 inches tall, fertilize following soil test recommendations. Keep the fertilizer off the leaves and 3 inches away from the stems of the plants. Avoid overhead watering and never touch the plants when they are wet.

Beets are easily grown from seed. Sow seed ½ to 1 inch deep and 1 inch apart. Beets can be planted in early spring as soon as the soil can be worked and planting can continue at three-week intervals until 60 days before maximum daytime temperatures are expected to average about 80 F. In late summer, when maximum average daytime temperatures are below 80 F, start successive plantings until 10 to 12 weeks before minimum night temperatures average below 20 F; beets are not harmed by spring and fall frost. Seed can be expected to germinate in six days at a soil temperature of 68 F or higher. An adequate and steady supply of moisture is critical for a healthy crop, as beets need to grow quickly without interruption. Beets are not heavy users of soil nutrients, but a balanced fertilizer may be added when plants are half grown.

Broccoli, Cabbage and Cauliflower are cool season crops. They grow and produce the best yields with cool weather conditions. For Oklahoma, this means transplanting seedlings in early spring or late summer. Set transplants in the soil at the level of the first set of leaves. Plant these cool season crops 1½ feet apart in rows 3 feet apart. They grow best at a soil pH in the range of 6.0 to 7.5. All require full sun and a rich fertile soil. These brassica vegetables are all heavily attacked by cabbage loopers and other foliar feeding caterpillars, therefore repeated applications of an insecticide such as Bt is essential to successful production of these vegetables.

Carrots grow best in light, sandy soil with a pH of 6.0 to 7.0. However, carrots can be successfully grown in heavier textured soil. Soils with high levels of clay are not favorable for carrot production. Carrots are most tasty when they are young; it is a good idea to sow successive plantings at three-week intervals. They grow best when temperatures are between 40 F to 80 F. Carrots will not grow well when maximum temperatures average over 88 F. They will grow well as long as nighttime temperatures do not dip below 32 F. Once mature, fall carrots can be mulched and “stored” in the garden. Sow seeds about ½ inch apart, ¼ inch deep in rows 6 to 8 inches apart. Sow a few seeds of radish in with the carrots; radishes sprout quickly and will mark the row until the carrots emerge. To prevent the soil from crusting and prohibiting the emergence of the carrot seedlings, lightly cover the soil surface with some type of mulch, i.e. grass clippings. A few days after the seedlings emerge, thin them to a spacing of 1 inch between plants. When the carrots become ½ inch thick, dig away some soil to check for size. Pull every other plant, making the final spacing 2 inches between plants. Do not discard the pulled plants; though thin, they are edible and delicious at this stage. Fertilize twice – when the plants are 3 to 4 inches tall and when they are 6 to 8 inches tall; scatter a 6- to 8-inch band of 5-10-10 fertilizer along each side of the row at the rate of 5 ounces per 10 feet of row. After each application of fertilizer, pile about ½ inch of soil around the base of each plant to prevent the tops of the roots from turning green from exposure to light. Carrots become fully mature 65 to 85 days after planting.

Cucumbers are easily grown from seed. All varieties need a full sun location and fertile, well-drained soil. Sow a seed every 6 inches and thin to one per foot when seedlings are 2 inches high. Cucumber seedlings require high amounts of soil moisture and nutrients. Fertilize at the time of planting and once a month thereafter. Growing cucumbers on a trellis or in cages can improve production by providing better air movement and lowering disease pressure. Cucumbers need pollinators (bees, etc.) to provide for full pollination of the female flowers. To maximize yield, cucumbers need to be harvested frequently. If cucumbers are left on the vine, the plant will stop producing new fruit. They should be harvested in the morning when they are cool and firm, then stored in the refrigerator.

Eggplant is supposed to have come from the Far East, either from tropical India or China. It is a staple vegetable in many oriental countries, but of only minor importance in the U.S. There are white, yellow, dark purple, brown, green and striped varieties of various shapes. The dark purple, large-fruited types are the only ones grown to any extent in Oklahoma. Eggplant requires very warm weather – night temperatures of at least 55 F and day temperatures of at least 80 F – for a period of about 2½ months after the young plants are set in the garden. The transplants should not be transplanted to the garden until the night temperatures can be depended upon to stay above 55 F. Night temperatures below 55 F can stunt young plants and stunted plants will not bear fruit. Plants should be spaced 2½ to 3 feet apart in rows 2½ feet apart. Pour 1 pint of fertilizer starter solution around each plant; provide adequate water. Every three to four weeks, scatter 1/8 cup of 10-20-10 in a 1 ½-foot band around each plant.

Kale is a member of the cabbage family and is grown extensively for greens. It is a hardy cool-season crop well adapted to winter growing in much of Oklahoma. Seed is usually planted in rows 18 to 24 inches apart and the plants thinned to a spacing of 5 to 6 inches. The entire kale plant is edible. One great thing about kale is its nutritional value. Kale has some of the highest levels of calcium, vitamins C and A and is the vegetable with the highest levels of lutein. Kale has a generally slower growth rate than other leafy vegetables, but it makes up for that with its super cold tolerance.

Kohlrabi is a cool-season member of the cabbage family grown for the swollen turnip-shaped portion of its stem, which rests on the soil surface. It grows best in soils with a pH of 6.0 to 7.5. Sow seeds in the early spring as soon as the soil can be worked and continue to sow at two week intervals. Group three to four seeds in a spot, planting each group ½ inch deep and 6 inches apart in rows 18 to 24 inches apart. When the seedlings reach 1 to 1 ½ inches, remove all but the strongest plant in the group. At three-week intervals scatter 10-10-10 fertilizer around the plant at a rate of 5 ounces per 10 feet of row. Keep the soil constantly moist. Kohlrabi roots grow close to the soil surface and are easily damaged by drought conditions and cultivation.

Okra is a warm-season vegetable, grown for its immature seed pods. It can be breaded and fried, pickled or for real okra lovers. . . stewed.

Okra is relatively easy to grow, except that it is susceptible to seedling diseases and is difficult to establish in cool soils. Once the plants are growing well, they are relatively free of insect and disease problems, with the exception of root-knot nematode. Root-knot nematode is a serious pest that can cause significant reduction in pod production. Okra grows best in soils with a pH of 6.0 to 8.0. Okra seed can be sown directly in the garden after the night temperatures are expected to remain above 50 F and soil temperatures are in the low 70s F. Group three or four seeds in a spot, setting each group ½ inch deep and 18 inches apart in rows 3 feet apart. With early plantings the seed should be treated with a seed treatment fungicide to prevent seedling diseases. When the seedlings become 1 inch tall, cut off all but the strongest in each group. Fertilize twice – when the plants are 8 to 12 inches tall and again just as they begin to bloom. Scatter a 12-inch band of 10-20-10 around each plant at the rate of 2 ½ ounces to every foot of row. Okra begins to produce pods about 60 days after seeds are sown. The pods develop very rapidly and should be picked daily within a few days after the flower petals have fallen, whether the pods are to be used or not. If pods are allowed to ripen, the plants cease to produce.

Onions should be started early in the growing season. In February, plant bare-root transplants, container-grown transplants, or sets (bulblets) in well-drained, loose, fertile soil. Grow onions in full sun. Onions have shallow roots and need constant moisture. They require about 1 inch of water per week to produce a good bulb. Because of the shallow root system, care should be taken when cultivating. Onions are heavy users of soil nutrients; therefore special attention has to be paid to the onion fertility program. One method of fertilizing onions is to apply and work in a pound of rotted manure for each square foot of soil before planting. In addition, mix in 1½ quarts of 10-20-10 per 100 square feet. Another option is to fertilize the onion plants twice – when they are about 6 inches tall and again when they are about 12 inches tall. Scatter a 4-inch band of 10-20-10 along each side of the row at the rate of 3 ounces per 20 feet of row. Onions can be grown three ways. 1) start transplants in a high tunnel or greenhouse; 2) purchase bare-rooted plants ready to transplant into the soil; and 3) grow from sets (small bulbs). In all cases, set the plants 3 to 4 inches apart and about 2 inches deep

to make good bulbs. These are grown primarily for producing “green onions” but will often produce reasonably sized bulbs. The nature of the onion is to grow tips in cool weather and form bulbs as the days get longer. The timing of bulbing is controlled mainly by day length. The varieties for the south are triggered to bulb at about 12 hours of daylight as the weather warms in early summer. The vernal equinox, or 12 hours of daylight, is March 21. Therefore, gardeners in Oklahoma must get the onions planted early to develop good tops and root systems before bulbing begins; plant short-day types by early March and medium daylength (and day neutral) types by late March. Each leaf makes a ring in the onion bulb. Therefore, good top growth produces larger onions.

Peppers are a warm-season crop. They grow best in soils with a pH of 5.5 to 7.0. Peppers are usually established in the garden as transplants. The transplants should be set out at least two weeks after the air temperature can be relied upon to stay above 55 F. Set the plants 18 to 24 inches apart in rows 2 to 3 feet apart. To prevent cutworm injury, cover the plants with paper cups that have had the bottoms removed. Fertilize twice – when the plants are about 8 inches tall and again when they are about 12 inches tall. If applying 10-20-10, it should be applied as an 8- to 12-inch band along each side of the row at the rate of 2½ ounces per 10 feet of row. Both sweet peppers and hot peppers are edible and flavorful at all stages of their growth. When picking peppers, cut them from the plant instead of pulling them off; the branches are extremely brittle and will break easily if the fruit is pulled off. The peppers grown in Oklahoma are the sweet and hot types. The hot peppers were the first of these to be grown by early gardeners and their seed is the source of the red pepper. However, these plants do not produce the white and black pepper used commercially as condiments. This type of pepper comes from an entirely different group of plants.

Potatoes grow best as a spring crop sown in early to mid-March. Fall potatoes can be grown, but soil must be heavily mulched to keep it cool enough for successful growth. Choose only certified disease-free potatoes for planting. Cut into 2- to 3-ounce pieces with two eyes per piece. Allow the cut surfaces to heal for a day or two before planting. Plant potatoes in soil that is slightly

acidic; pH 6.0 to 6.5 is ideal. Planting in soils with a pH of 6.8 to 7.0 or higher will cause potatoes to develop a disease called scab. Planting potatoes in areas where wood ashes have been heavily applied can lead to problems with scab. Make sure that adequate N, P and K are worked into the soil before planting. Soils must be deep and well-drained, however very sandy soils will not retain enough moisture to form a good-sized tuber. Plant tuber pieces four inches deep and about 10 inches apart in 36 inch rows. After planting heap 6 inches of soil over the open furrow. A few weeks later, when shoots are 4 to 6 inches above the soil line, hill soil up again to stimulate plenty of tuber formation. Keep soil evenly moist, but not soggy. To control Colorado potato beetle infestations, crush any bright yellow clusters of eggs found on the undersides of leaves.

Pumpkins require full sun locations. Most varieties of pumpkin grown in Oklahoma are vine-type plants that require 100 to 120 days to mature. Pumpkin plants need plenty of space since the longest vines will grow to more than 12 feet. Cultivate the soil and sow seed into warm garden soil after the danger of frost is past. Planting hills should be spaced 8 to 10 feet apart for vine types. Plant four to six seeds in each hill. Cover seeds with 2 inches of soil, water and keep the soil moist for germination, which will take about 10 to 14 days. Seedlings should be thinned to the two or three strongest plants in a given hill once seedlings have reached two inches in height. Pumpkins do not need to be pampered. Weed by hand to avoid damaging the extensive root system and water plants thoroughly once a week in the absence of rainfall. Pumpkins need pollinators (bees, etc.) to provide for full pollination of the female flowers, so be certain to manage insect sprays and other management issues to provide a "bee-friendly" environment. From late summer on, remove any blossoms or new fruit to channel plant energies into the fruit that have already formed. Pumpkins grow best at a soil pH between 6.5 and 7.0. They require adequate amounts of P and K; extra N will need to be applied when the plants are three weeks old at the rate equivalent to 40 to 50 pounds of nitrogen per acre.

Radishes are one of the quickest vegetables to grow. Sow radish seed, and in 21 days, harvest the crunchy red globes. There are basically two shapes, round and tapered like a carrot. Radishes are easily grown from direct seeding in the garden.

They require full sun with loose, even sandy, well-drained soil and prefer a soil pH of 6.0 to 7.0. Sow seed about four weeks before the first frost free date. Seed will germinate at soil temperatures of 60 F or above in seven days or less. Young seedlings should be thinned to at least 1 inch apart. Some gardeners will sow a small quantity of seed every seven to 10 days to harvest fresh radishes over a longer time frame. Radishes can be planted up to approximately 30 days before maximum daytime temperatures are expected to average over 80 F. Fall radishes can be grown and should be planted about 30 days before the maximum daytime temperature average is below 80 F. Fall planting can be continued until night temperatures drop to about 40 F.

Rhubarb is grown for its stout stalks, which are 18 to 36 inches long, bright red or green. It is a cold-resistant, long-lived perennial, but often does not perform well due to Oklahoma's long and hot summers. For trial plantings it grows best in soil with a pH of 5.5 to 7.0. To establish rhubarb, plant roots in early spring when the soil can be worked, and where they can grow undisturbed for many years. Prepare the soil by digging a hole about 2 feet deep and 2 feet across for each plant, spacing the plants 3 feet apart. Place a 6- to 8-inch layer of compost or well-rotted cow manure in the bottom of each hole and fill the hole with a mixture of equal parts compost and topsoil. Set the plants into the holes so the tops of the roots (where the buds are located) are 3 to 4 inches below the surface of the soil. Each fall spread a 3-inch layer of mulch or compost over the soil surface.

Sweet Corn is an easy crop to establish in the garden. It grows well with little maintenance, with the exception of insect control. The corn ear worm is a major pest on sweet corn and will cause extensive damage to the "ears" if control measures are not employed throughout the time the corn is silking and developing fruit. Sweet corn grows best in soil with a pH of 6.0 to 7.0. Seed can be planted in the spring when danger of frost is past. Plant early-maturing, mid-season and late varieties at the same time as early varieties or make successive plantings of early varieties every two weeks to obtain a longer supply of fresh ears. Since corn is wind-pollinated and pollen cannot travel far, corn needs to be planted in multiple rows (blocks) using four rows as the minimum to ensure good pollination. Plant the seed about 1 ½ inches deep and

3 to 4 inches apart. Space rows 2 to 3 feet apart. Corn plantings should be thinned when the plants are 2 to 4 inches tall, to a spacing of 12 inches between plants. Fertilize the plants when they are approximately 4 inches tall, scattering a 6-inch band of 10-20-10 fertilizer at the rate of 2½ to 4 ounces for 10 feet of row. Irrigate regularly, controlling both weeds and insects on a regular basis.

Tomatoes are warm-season vegetables that like warm soil and warm air. They are susceptible to frost injury. Cold temperatures interfere with pollination and the development of fruit. If tomatoes are planted too early, the first fruits will likely be misshapen from poor pollination and have blossom-end-rot, which is directly related to cool temperatures of the air and soil. One of the most important points in successfully growing tomatoes is to start with good varieties. A few of the recommended varieties for Oklahoma are found in Table 4.20. For additional tomato growing tips see HLA-6012 *Growing Tomatoes in the Home Garden*. Other varieties also may be grown, but little information on how they grow with conditions in Oklahoma will be available. Whether a gardener selects an OSU-recommended variety or some other variety, it is always advisable to select varieties that have good disease and nematode resistance. These are denoted by VFNT, which stands for Verticillium, Fusarium, Root-knot nematode and Tobacco mosaic virus resistance.

Tomato tips

- Plant tomatoes in a location that receives full sun. Tomatoes react adversely to shade. If a planting location is shaded for half the day, the tomatoes will produce half a crop or less.
- Purchase strong, stocky plants that have been toughened or hardened off. Avoid spindly plants.
- Select a cool, cloudy day for transplanting or in the late afternoon if possible. Be ready to cover the plants in case of frost. At planting and for several weeks after planting, do not apply organic mulches on the soil, because they will slow the warming of the soil. The soil temperature needs to be around 65 F or warmer for the tomatoes to take off and grow well.
- Set the plants in the planting hole. If plants are tall and somewhat spindly, lay the stem horizontally and cover with soil – roots will develop along the soil-covered stem.

Table 4.20. Recommended tomato varieties.

<i>Small Fruit</i>	<i>Large Fruit</i>	<i>Paste</i>
Juliet	Better Boy VFN	Milano VF
Mountain Bell VF	Big Beef VNF2AST	Roma VFN (canning)
Small Fry VFN	Bigset VF2NAS	San Remo VF
Sweet 100	Brandywine	
Pixie	Carmello VNFT	
Sungold FT	Carnival VNF2	
Sweet Million FNT	Celebrity VNF2T	
Yellow Pear	Flora-dade VF2	
	Heatwave VF2	
	Jet Star VF	
	Mountain Pride VF	
	Pik-Red VNF2	
	Summer Flavor 5000 VNF2	
	Sunny VF2AS	
	Sunray F (yellow)	
	Sunrise VF2	

Disease resistance or tolerance codes: Verticillium wilt (V), Fusarium wilt, Race 1 (F), Fusarium wilt, Races 1 & 2, (F2), Root-Knot nematode (N), Tobacco mosaic virus (T), Alternaria stem canker (A), and Stemphylium (gray leaf spot) (S).

- Pour 1 pint of a fertilizer starter solution around each plant.
- Protect new plants from the sun and wind by covering with hot caps, paper, etc., for two or three days.
- Do not over-apply nitrogen. Too much nitrogen or too much water in early growth stages can result in the tomato plant remaining in a vegetative stage. This results in no fruit. Too much shade can cause the same problem.
- When the plants start blooming, cover the soil with 5 to 6 inches of mulch. Use straw, grass clippings or any commercial mulch. This will conserve moisture, keep the soil cooler, eliminate hand hoeing and reduce foliar and fruit rot diseases.
- When the plants have developed fruit about the size of golf balls, scatter 3 to 4 tablespoons of 36-0-0 fertilizer around each plant and water. Fertilize each month thereafter and water regularly.
- For better quality fruit, stake, tie and prune tomatoes as they grow. Many prefer to use a circular cage made from 6 feet of concrete reinforcing wire. Cut out the bottom horizontals

and shove cage into the soil surrounding the tomato plant.

- Be prepared to protect the plant from insects, such as tomato fruit worm and spider mites, and diseases. Keep insecticides and fungicides handy so applications can be made at the first signs of trouble.

Watermelons, depending on variety, require from 70 to 100 days to mature. An early jump can be obtained by sowing seeds indoors and transplanting to the garden after the danger of frost has passed. During the growing season, watermelon plants need water and adequate nutrients to produce melons. A balanced granular fertilizer can be applied at flowering and a month later. Watermelons need pollinators (bees, etc.) to provide for full pollination of the female flowers, so be certain to manage insect sprays and other management issues to provide a “bee-friendly” environment. A uniform irrigation program needs to be followed to prevent blossom end rot or misshapen fruit.

Harvest Hints

Harvesting vegetables at the peak of their quality allows the gardener to reap the dividends of their efforts. Few things are as satisfying as harvesting and consuming fresh home-grown vegetables at their peak of maturity. Be sure to harvest when foliage is dry.

Asparagus: Asparagus must grow one full year after being planted before harvesting. The second year, spears can be snapped for about a week with the harvest period expanding by one additional week each succeeding year. When crowns become well established, harvest may last up to eight weeks. One rule of thumb to remember is that when the asparagus spears become smaller than a pencil in diameter, stop harvesting because carbohydrates in the crown are close to depletion. Asparagus shoots grow very rapidly and require frequent harvesting, especially if the temperature is high. Early in the season, the shoots may require snapping only every third day. But, as the growth becomes more active, the spears may have to be snapped twice a day. Do not cut (harvest) spears with a knife. Knife injury to buds and immature shoots causes them to develop into crooked spears. Simply snap the spears off at ground level with the thumb and forefinger.

Lima bean: Harvesting of green lima beans should begin when the seeds reach full size and are light green in color, but before the pods show any yellowing. The seeds turn white as they mature. Over-mature seeds are high in carbohydrates and low in sugar, but if allowed to remain in the bush until dry, they make suitable dry beans.

Snap bean: Start harvesting snap beans when the pods reach full length but are still young and tender. Quality decreases as the seed enlarge. A snap bean ready to harvest should break easily; with a snap as the name implies. Harvest frequently during warm weather. Pod set is often very poor when temperatures exceed 90 F.

Beet: Beets can be harvested when they are 1 to 1 ½ inches in diameter and this is the most desirable stage if the tops are to be used as greens. If the tops are not going to be consumed as greens, the roots remain tender up to 2 ½ to 3 inches in diameter.

Broccoli: Broccoli should be harvested when the individual flower buds are the size of a match head, but before they show yellow. After the central heads are harvested, small heads will develop on lateral branches. These lateral heads are ideal for freezing.

Brussels sprouts: Brussels sprouts can be harvested over a considerable period if the lower sprouts are picked when they become firm. The leaf below each sprout is usually broken off so each sprout can be picked easily. The plant continues to produce more leaves and sprouts at the top. At the onset of freezing weather, the plants with good sprouts can be mulched up to the top of the plant with dry hay or straw, held in place by a burlap bag or plastic row covers. The cold, sweetened sprouts can then be harvested throughout the winter.

Cabbage: Cabbage can be harvested as soon as the head grows to about soft ball size and is of sufficient firmness. Heads split as they become over-mature. Heads harvested before splitting can be stored for long periods at a storage temperature between 45 F and 32 F. Heads which are to be stored should be solid and free from disease and harvesting injury. Mature cabbage can also be “stored” in the garden for several weeks after fall frosts occur.

Carrot: Harvesting begins when the roots are ½ to ¾ inch in diameter at the upper end. If grown as a fall crop, they will store in the ground to be pulled as needed. Fall carrot production often re-

sults in carrots that are sweeter than those grown in the spring because night temperatures cool off considerably resulting in less respiration (burning off sugars).

Cauliflower: The curd or edible part of the cauliflower plant should be protected from sunlight (blanched) to develop a good white color. However, off-colored heads are edible. While the curd is small it is protected from direct sunlight by the surrounding leaves, but as the curd matures, the leaves of the plant begin to spread away from the curd, allowing exposure to direct sunlight. To prevent this, the leaves should be tied together above the curd. The curd should be ready for harvest two to three weeks after tying. Harvest when the curd is still compact and fairly smooth. Self-blanching varieties tend to wrap their own leaves around the curd.

Collard: Harvest older leaves when they reach a length of 8 to 12 inches. New leaves will grow as long as the central growing point remains, providing a continuous harvest. Whole plants may be harvested and cooked if desired.

Sweet corn: Older sweet corn varieties (su1 genetics) should be harvested when the kernels are in the "milk" stage. At this stage of maturity, the watery sap in the kernels will be a milky color and will squirt out freely when pressed by the thumbnail. Newer sweet corn varieties such as the "Sugar Enhanced" (se genetics) types and "Super Sweets" (sh2 genetics) types will not develop a milky sap in the kernels at maturity. These types can be checked for maturity by looking for brown silks, feeling the overall ear for fullness, and in yellow and bi-color types, look for yellow kernel color to develop. White varieties can be assessed for maturity by the brown silks, ear filling and tasting for sweetness. Much like several other crops; sweet corn passes the prime eating stage quickly, especially in hot weather.

Cucumber: Harvest cucumbers while the fruit are young and the seeds are soft. A yellowing color indicates that the seeds are mature and the fruit are beyond the edible stage. Bitterness often is directly related to over-maturity. Harvest every other day; over-mature and/or poorly shaped fruit should be removed from the vine.

Eggplant: Eggplant should be harvested when they reach a uniformly deep purple color and are properly sized for the variety, which is when the fruit is about 6 inches long and very

shiny. Generally, this is about 70 days after seedlings are transplanted. Fruit in which the seeds have turned brown are of poor quality, and past the edible stage. All fruit should be removed from the plant before they mature; otherwise the plants stop producing.

Kohlrabi: Kohlrabi is grown for the turnip-like enlargement of the stem. It is tasty if picked while tender and cooked like cauliflower, or sliced and served raw. With a good supply of moisture, it is easily grown in either hot or cold weather. Kohlrabi is ready to be picked about eight weeks after sowing, when the stems are about the size of an apple or 2 to 2 ½ inches across. Kohlrabi must be grown rapidly and harvested when 1 ½ to 3 inches in diameter or it will become tough and stringy.

Lettuce: Harvest older, outer leaves from leaf lettuce as soon as they are 4 to 6 inches long. Harvest heading types when the heads are moderately firm and before seed stalks form.

Melon: Melons (cantaloupe and muskmelon) can rapidly pass prime eating quality. During warm weather, a daily harvest is necessary. As a cantaloupe or muskmelon ripens, the color between the netting changes from light green to tan or yellow. Once the melon becomes mature and the color becomes a uniform tan, the stem will easily come loose from the melon with a gentle pull. This is known as the slip state. Many people like to chill the melon in the refrigerator before eating. However, the flavor is also good at higher temperatures. If it becomes necessary to harvest slightly immature melons, they can be ripened by holding at room temperature, but the sweetness will not increase after they are removed from the vine.

Mustard: Harvest the leaves and leaf stems (petioles) when they are 6 to 8 inches long; new leaves will provide a continuous harvest until they become strong in flavor and tough in texture from temperature extremes.

Okra: Harvest young, tender pods when they are 2 to 3 inches long. Pick at least every other day (preferably every day) during the peak growing season. Over-mature pods become woody and are too tough to eat. Harvest often to maintain production. Plants will stop flowering and fruiting once seed pods begin to mature.

Onion: When onions are mature, the tops will fall over. If harvesting the entire planting at once, time the harvest based on when half the tops have fallen over. If harvesting as needed, pull individual

bulbs as their tops fall over. After tops have fallen, either pull the onion or undercut the onion and allow them to begin drying down in the garden for a day or two. Then pull or dig the onion bulbs and gently shake off the soil, but do not wash them. Place the onion bulbs in the shade on wire screens for 7 to 10 days for further drying and curing. After the drying period, cut off the tops about 1 inch from the bulb and store in mesh bags in a cool, dry place.

Pea: Peas should be harvested just before the seeds reach their full size. Harvest should begin when the pods are well filled and plump, but not before they reach the stage where they appear ready to burst. At this point, the seeds are very high in sugar content. After the peas reach harvest maturity, they begin a rapid decline from the standpoint of edibility. From this point on, the longer they remain on the vine the poorer the quality. The higher the temperature, the quicker they pass peak quality.

Pepper: Peppers are usually harvested after reaching full size. Conventionally, the green mature fruit are harvested, however, the fruit may be allowed to mature (turn red) before harvesting.

Pumpkin and winter squash: Winter squash and pumpkins can be harvested after they have developed the appropriate color for the variety and a hard rind. If the rind of the fruit cannot be penetrated with the thumbnail, the fruit is mature. The fruit should be harvested before the first hard freeze, since they are injured by cold temperatures. Cut the stem from the vine, leaving 2 to 4 inches of vine on the fruit. Fruit without a stem will not store well.

Potato: Potatoes can be harvested any time for immediate consumption once the tubers are of sufficient size. However, yield is reduced and storage quality is lowered by harvesting tubers before the tops dry down. Tubers harvested early (immature tubers) have thin skins that allow fairly rapid water loss, causing the tubers to shrivel and become soft after short periods of storage. In Oklahoma, harvest of mature tubers occurs in late June to early July. Storage potatoes should be harvested one or two weeks after the vines dry down. If being grown as a fall crop, harvest before there is danger of freezing. After harvest, the tubers should be stored in a dark, moist area at approximately 60 F for several weeks. Temperatures should be lowered to 40 F to 42 F for long-

term storage. Storing potatoes at this temperature keeps them from sprouting and maintains them in firm physical condition. Warmer temperatures allow sprouting to take place. Colder temperatures cause a sweet taste and can result in discoloration of the inside of the tubers. Whatever the storage temperature, keep the potatoes in complete darkness. Exposure to light causes the tubers to turn green and develop undesirable levels of bitter-tasting compounds.

Radish: Radishes develop poor shape and go to seed quickly during hot weather. Therefore, radishes should be harvested as soon as roots are the preferred size.

Rhubarb: Start harvest one year after planting. Harvest begins in early spring when the stalks are 12 to 18 inches long. When harvesting rhubarb, the leaf stalks are pulled, not cut. The leaf stem (petiole) is the part of the plant which is eaten. Leaves contain toxic levels of oxalic acid. **DO NOT EAT THE LEAFY PORTION.** The leaf blades are removed from the fleshy stem. Always leave a few stalks on the plant unless the bed is to be abandoned. Harvest of mature plants should continue for 8 to 10 weeks. After 10 to 15 years, the plants become crowded and the leaf petioles become small and undesirable for consumption.

Spinach: Spinach may be harvested from the time the plants have 6 to 8 leaves until the seed stem develops. The entire plant can be cut off at soil level or just pick the outer leaves.

Summer squash: Summer squash should be harvested and used while young and tender. Fruit 6 to 8 inches long and 1 ½ to 2 inches in diameter are ideal. If the rind of the fruit can't be penetrated with slight pressure of the thumbnail, it is too old for the table. The very large fruit, especially zucchini, can be used for stuffing; however the quality of the vegetable isn't very high. Remove old fruit from the plant immediately to permit new flowers and fruit to develop.

Sweet potato: Harvest the roots when they are large enough for use before frost. Avoid bruising or scratching during harvesting and handling. Damaged sweet potatoes rot easily in storage. Sweet potato can be consumed any time after harvest. To prepare sweet potato for extended storage they will need to be "cured." Home curing of potatoes can be done using a small heater to bring the room temperature up to 85 F to 90F. Use a small humidifier to humidify the air in the curing room

and a fan to circulate the warm humid air through to potatoes. Sweet potatoes should be cured for 7 to 10 days under these conditions to heal harvest wounds. After this they can be held for several months in storage. Ideal storage conditions are a temperature of 55 F and a relative humidity of 85 percent.

Swiss chard: Harvesting Swiss chard can begin any time after the plants develop four to five leaves. The full-grown leaves are cut 1 to 2 inches from the point in the center, so new leaves will continue to form and develop. Old leaves are tough and should be cut and discarded.

Tomato: During warm weather, tomato fruit should be harvested twice a week. Tomatoes can be harvested as early as the “breaker state” (when a slight pink color appears on the bottom of the fruit). If the fruit is stored at 70 F and out of direct sunlight, they will continue to ripen. This early harvesting does not decrease the quality of taste of the tomato fruit. The fruit can also be left on the plant until it turns red. It should be removed from the plant while it is still firm. Allowing the fruit to remain on the plant until full maturity increases the chances of the fruit cracking and other physical

damage to the fruit. Cracking is more of a problem after a rain.

Watermelon: Determining the maturity of a watermelon takes a little practice and varies for different types and varieties. Before looking for signs of maturity, wait until the fruit reaches the size described in the seed catalog. When the fruit becomes full size, check the color of the rind where it touches the soil. A ripe melon will have a buttery yellow color on the underneath side also called the ground spot. There also is a small green tendril (curly-cue) on the stem just before where it attaches to the melon. When this tendril turns brown, it is sign the melon is near maturity. Another sign of ripening is the development of a “dull” cast to the fruit surface caused from the fruit exuding waxes on the fruit surface to protect the fruit. Some experts can tell if a melon is ripe by the sound and feel when a melon is thumped with knuckles. A metallic ring indicates immaturity and a dull or muffled sound indicates ripeness. Also, when holding the melon in one hand and thumping with the knuckles, a vibration within the melon can be detected. Feeling a definite, deep and uniform vibration indicates ripeness.

Chapter 5: FRUITS AND NUTS IN THE HOME GARDEN

Learning Objectives:

After completing this section, Master Gardener trainees will be able to:

- Describe the factors to consider in planning to grow fruit and nut crops in Oklahoma.
- Describe several types of fruits and the culture of each.
- Understand growing requirements of fruits and nuts, including planting, fertilizing, pollination, pruning and other requirements.
- Know primary pests of fruits and nuts and understand control strategies, including IPM techniques.

Chapter 5: Fruits and Nuts	128
in the Home Garden	128
Planning the Home Fruit Planting	129
Site of planting	130
Site selection	130
Apples	132
Berries	137
Blackberries	137
Blueberries	141
Raspberries	144
Strawberries	144
Bunch Grapes	145
Muscadine Grapes	148
Pears	151
Pecans	154
Stone Fruits	159
Peaches and Nectarines	163
Plums	164
Apricots	165
Cherries	165
Other Crops	165
Elderberry	165
Jujubes	166
Kiwifruit	167
Persimmons	168
Pomegranates	169

Well-established and properly maintained fruit plantings can be productive, beautiful in a home landscape and serve as a satisfying hobby. To be successful, most fruit crops require years of patient care and hard work. Some people are not willing or able to devote time to a fruit planting and will be disappointed in its harvest.

Some fruits require more care than others. Tree fruits and grapes usually require more protection from insects and diseases than blueberries and blackberries. Generally speaking, flowers and fruits of fruit trees must be protected by both fungicide and insecticide sprays from before blossom-time until harvest. In addition, sprays may be required to protect the leaves, trunk and branches.

Small fruits are perhaps the most desirable of all fruits in the home garden, since they come into bearing in a shorter time and usually require few or no insecticide or fungicide sprays. Strawberries are the first spring fruit to ripen. Their low-growing, dark green foliage can serve as a dense ground cover around patios, in raised beds or in attractive pyramids.

Blackberries are the next crop to ripen in late May or June. They provide excellent hedge plantings to outline property lines or discourage unwanted traffic. On acid soils, a hedge of blueberries provides high-quality fruit in late June and July.

Fruit trees add long-lasting beauty to the home landscape. Pear trees contribute dark, spreading

foliage and beautiful spring blossoms, plus attractive fall colors. Persimmons and jujubes provide interesting focal points, color and usable fruit.

Other tree crops requiring more care include the pecan, plum, apple and peach. Pecan trees are known for their shade, beauty and abundant nut production. Fast-growing plum trees have profuse spring blooms. Southern apples produce bushy trees with attractive blooms and fruit.

Despite the popularity of peach trees, their susceptibility to insects and disease can discourage home fruit growers. Still, many homeowners do quite well with peaches.

Untold amounts of money have been lost because the planted fruit trees were either neglected

or not adapted to Oklahoma conditions. Successful fruit culture requires an understanding of planting methods; site, soil and variety selection; and pruning, training and related practices. Even small orchards require basic tools and equipment.

Fresh fruits can be available throughout the growing season with proper selection of types and cultivars (varieties) (Table 5.1).

Planning the Home Fruit Planting

It is best to locate the fruit planting as close to the home as possible, but in sunny locations. Sun-

Table 5.1. Approximate harvest season for fruits in Oklahoma.

<i>Fruits</i>	<i>Jan</i>	<i>Feb</i>	<i>Mar</i>	<i>Apr</i>	<i>May</i>	<i>June</i>	<i>July</i>	<i>Aug</i>	<i>Sept</i>	<i>Oct</i>	<i>Nov</i>	<i>Dec</i>
Apple												
Apricot												
Blackberry												
Blueberry												
Cherry												
Elderberry												
Fig												
Grape												
Jujube												
Peach												
Pecan												
Persimmon												
Plum												
Pomegranate												
Strawberry												

light is the key to fruit production. Anything less than full sunlight reduces production.

Where space is limited, fruit trees may be set in almost any location suitable for ornamental plants. However, because fallen fruit in a lawn can present problems, harvest must be prompt.

When planting, consider the mature size of the tree. Most nurseries now carry several varieties of dwarf and semi-dwarf apple trees. Some nurseries offer a few varieties of dwarf pear and peach trees. Consider planting dwarf trees in any area where space is at a premium, but keep the number of trees low. Columnar forms of apple are also available.

Size of planting

Planting size is determined by space, site, family size, available time and pollination requirements. The range of fruits planted should depend on family preference, adaptability and space.

Never plant more than you can care for properly. It is better to have a small, well-tended home orchard than a large, neglected one.

The information in Table 5.2 should help determine the size of the planting. For instance, only one peach tree is required for production, but at least two apple trees are needed to ensure cross-pollination. Pay close attention to the pollination requirements of the different fruits to avoid dis-

Table 5.2. Pollination requirements of fruit crops.

<i>Self-fruit</i>	<i>Need pollinators</i>
Apricot	Apple
Blackberry	Blueberry*
Fig	Plum (Japanese)
Grape	Walnut
Jujube	Grape (muscadine)
Nectarine	Pear
Peach	Pecan
Persimmon	
Plum*	
Pomegranate	
Strawberry	

*Some varieties require cross-pollination for good fruit production; Bruce plum will need a pollinator; Tifblue blueberry will not.

appointment. Many fruits require the flower to be pollinated from a different cultivar of the same fruit or the fruit will not develop. Planting only one cultivar of these fruits may result in masses of blooms in the spring, but few or no fruits. Different strains of the same cultivar (e.g. two spur strains of ‘Delicious’) will not provide proper cross-pollination.

Site selection

The importance of selecting the best possible site for fruit planting cannot be overemphasized. Good air drainage is essential. Like water, cold air flows downhill. For this reason, the fruit buds on plants that are in a low spot are more likely to be killed than those on a slope. Avoid frost pockets, low wet spots and locations exposed to strong prevailing winds. South-facing slopes encourage early bud development and can sometimes result in frost damage. Make certain the air can move freely throughout the planting site and is not “boxed” in with surrounding terrain or tree borders.

Select deep, fertile, well-drained soil. A sandy loam or sandy clay loam is suitable for most fruit trees. Fertile soil is desirable, but deep, well-drained soil is vital. The most important soil characteristic is adequate drainage. Soils lacking in nutrition can easily be improved by proper fertilization and cultural practices, but it is difficult and expensive to improve poorly drained soil.

Determine the soil’s internal drainage rate by digging a hole 8 inches in diameter and 3 feet deep. Fill it with water and allow to drain. Refill the hole with water and monitor the drainage. If it drains in 24 hours, the soil has excellent drainage and is suitable for all fruit crops. Peaches, apricot, plum and nectarine trees should be planted only on sites with excellent drainage.

If the hole drains in 36 hours, the internal drainage is adequate for more tolerant crops, such as fig, blueberry, strawberry, grape, apple and blackberry. Persimmon, pomegranate, jujube, pear and pecans are more adapted to heavier soils, but still require adequate drainage for good production.

If the hole hasn’t drained in 48 hours, the site is unsuitable for fruit production. In this case, plant on raised beds, berms or in containers.

When evaluating soil drainage, be sure to have the soil tested for salinity, pH level and nutrient content – specifically phosphorus and potassium. Phosphorus and potassium move very slowly into

Table 5.3. Planting guide for fruit crops.

<i>Fruit crop</i>	<i>Canopy diameter</i>	<i>Nursery stock*</i>	<i>Years to bearing</i>	<i>Potential yield (bushels)</i>	<i>Pollination</i>	<i>Notes</i>
Apple: Seedling rootstock	25 ft	3 to 4 ft	8	5 to 8	Cross	Large tree
Apple: M9 rootstock	10 ft	3 to 4 ft	3	0.5 to 1	Cross	Needs support
Apple: M111 rootstock	20 ft	3 to 4 ft	5	4-5	Cross	Semi-dwarf
Blackberry	1 ½ ft in row	Root cuttings	1 to 2	1 gal/2 ft of row	Self	
Blueberry	8 ft	2 years	4	15 lb	Cross	
Cherry, sour	20 ft	1 to 2 years	5	100 lb	Self	
Elderberry	8-10 ft	1 year, or rooted cuttings	1-3	12 to 15 lb	Cross	
Fig	12 ft	Rooted cuttings	2	25 lb	Self	
Grape, muscadine	20 ft in row	Rootings	3 to 4	35 lb	Cross	Needs trellis
Grape, hybrid vinifera	8 ft in row	Rootings	2 to 3	15 lb	Self	Needs trellis
Jujube	25 ft	3 to 4 ft	5	1 to 3	Self	Root sprouts
Pear	25 ft	3 to 4 ft	5	3 to 5	Cross	
Peach	18 ft	2 to 3 ft	3	1 to 2	Self	
Pecan	35 ft	6 to 8 ft	7	20 to 40 lb	Cross	
Persimmon	25 ft	2 to 3 ft	4	1 to 2	Self	
Plum	18 ft	3 to 4 ft	5	1 to 2	Cross	
Nectarine	18 ft	2 to 3 ft	3	1 to 2	Self	
Quince	15 ft	2 to 3 ft	4	2 to 3	Self	
Strawberry			1	1/3 lb	Self	

*Nursery stock refers to either plant size or grade.

the soil; if the planting site is deficient, it is easier to incorporate such nutrients before planting.

The best way to overcome salinity problems is to avoid them. If your soil's sodium absorption ratio is above 6 and/or electric conductivity is more than 4 millimhos per centimeter (mmhos/cm), it is best not to plant on this site. Consider growing plants in containers.

The soil pH will determine whether iron chlorosis will be a problem or not. If the pH is 7.5 and above, the site is highly alkaline; supplemental iron or a specific rootstock will be needed for trees to be healthy. If growing blueberries, the soil pH should be acidic or in the 4.5 to 5.0 range. Sulfur can help to lower pH. To raise pH levels, lime should be incorporated.

After evaluating the planting site, select fruit varieties adapted to your area. Consult experienced fruit producers and your county Extension educator for recommended varieties for your area. Select different varieties to extend the harvesting season.

Every spring, nursery catalogs advertise many "new and improved" varieties. Begin with varieties that have been proven dependable, but leave room for a few novelties. A new variety is usually suited to a particular part of the country. The planting range should be described in the catalog description; otherwise, buyer beware.

Draw a scale model of your orchard or fruit planting area using mature plant sizes (Table 5.3). Let soil, rainfall and slope determine the planting scheme.

Tree fruits not included in the list may grow in Oklahoma, but few consistently produce quality fruit. For example, apricot and sweet cherry trees can grow in certain areas where the climate is favorable, but they must be carefully managed and usually do not bear fruit consistently.

On level ground, plant north-to-south rows for good air movement and light exposure. On uneven ground, prepare terraces before planting, so the soil has a chance to settle. Plant contoured rows on gentle slopes, and set the plants on top of the

contours to ensure good water drainage. Large trees should be planted on the northern edge to prevent shading smaller crops.

Match plant sizes to the available space. For instance, select figs, strawberries, blackberries and similar crops for small sites. They bear fruit early and produce well in most areas. Small plants can be grown in containers, moved to accommodate orchard changes. Pecans, peaches and other trees need more space and require three to eight years to produce their first crop.

Living plants must be handled carefully for optimum performance. The ideal situation is to plant the trees the day you buy them, thus reducing the chance for root freezing or drying. If roots are dry, completely immerse the roots in water for a few minutes or overnight before planting.

Set trees the same depth as they grew in the nursery row. Trim off broken and dried roots. Place topsoil around the roots and firm the soil to exclude air. Settle the soil with water and make sure the roots are left in a natural outward position. Leave a small basin 1 or 2 inches deep around the tree to aid in watering. Prune back about one-third of the tree top. Wrap the trunk from the soil line up to the first branches (or 18 inches above the ground) to protect the trunk from sunscald, rodent injury, insect damage and drying out.

Once the trees are planted, the key for their growth will be weed control, fertilizer and water. Because newly planted trees do not compete well for water and nutrients, eliminate weed and grass from around the trees for the first four to five years. This allows the trees to perform better. Mulching around trees will decrease weed pressure and increase soil moisture. Weed control is the most critical cultural practice for establishment.

The trees will require fertilizer for maximum growth. The element most needed is nitrogen. Apply nitrogen after the buds begin to break and the trees begin to grow. Finally, water is needed to move the fertilizer not only into the soil, but also into the roots. Water affects a plant's ability to take in nutrients. Plants may experience nutrient deficiencies, when in reality, they lack water.

The production of quality fruit requires at least a few pest control sprays. If you are not committed to making a few applications of pesticides, you are probably better off not planting fruit or nut trees.

The number of sprays required can be reduced drastically by sanitation: keep the grass

closely mowed and remove the old fruit from the ground and the tree. This will reduce the disease inoculum present, which will lower chances of a pest problem.

Apples

Apples are a popular homegrown fruit and can be successfully cultivated in much of Oklahoma. The major problem limiting their success in some areas of Oklahoma is disease susceptibility. Purchase varieties that have disease resistance.

The other key to producing quality apples in a home orchard are variety selection and proper, timely care of the trees.

Site and soil requirements

For maximum production, apples need plentiful sunlight. Choose an area that will be in the sun most of the day; otherwise, expect reduced performance. Early-morning sun is particularly important to dry the dew from the leaves, which will reduce the incidence of diseases, but full sun is best.

Good soil drainage is more important than soil fertility. Avoid areas where water stands for more than 24 hours after rainfall. In such areas, the roots will die from insufficient oxygen, resulting in stunted growth and eventual death of the tree. If such conditions exist, planting on a raised terrace will help.

In areas with alkaline soils and a history of cotton root rot, avoid planting apples trees. They are very sensitive to root rot and no control is currently available.

Buying trees

When buying apple trees, an important consideration is the adage "you get what you pay for." Bargain plants may not be healthy or may not be a variety adapted to your area. Only buy trees of recommended varieties from a reliable source. Keep the following points in mind when buying apple trees:

- A healthy 1-year-old whip (a branchless shoot), about 3 to 4 feet tall with ½-inch diameter trunk and a good root system is preferred.
- A small tree with a good root system is more desirable than a large tree with a poor root system. Trees two years old or older are often not as good as one-year-old trees. The older trees

often have too few buds on the lower portion of the trunk to develop a good framework. If buying older trees, cut them back to force out buds lower on the main trunk.

- Do not buy trees that appear stunted, poorly grown, diseased or injured by insects.
- Check the labels closely to make sure the desired variety and rootstock is chosen. Do not purchase if the rootstock is not labeled.
- Do not buy dried, shriveled plants, even at discount prices.

Pollination

Apple varieties require pollen from another variety to set fruit. Therefore, plant two or more varieties with overlapping bloom periods. Some varieties bear heavy crops when pollinated by another pollen-producing variety, but do not themselves produce good pollen. Trees grafted with more than one variety (five-in-one, fruit cocktail trees) do not give good results. One variety generally crowds out the others. Table 5.4 lists common and promising varieties of apples for planting in Oklahoma.

Variety selection

Many of the 6,000 named apple varieties have given way to superior tasting varieties. Some apple varieties, such as 'Red Delicious' and 'Golden Delicious,' are also available in various strains. A strain is a mutation of a variety selected and propagated for an improved characteristic. Strains may differ in fruit characteristics, growth characteristics, or both. Some varieties have many strains; for example, about 250 strains of 'Red Delicious' have been described and cultivated.

Spend considerable time studying these varieties. Keep in mind that these will live for several decades. Choose several varieties to provide apples for desired use: processing into apple sauce, cider and apple butter; dessert/fresh eating right off the tree; and long storage in the refrigerator.

Strain types may be spur or nonspur. Spur-type strains are ideally suited for home gardeners with space limitations because the fruit spurs and leaf buds are spaced more closely than on nonspur trees. Two-year-old wood on spur-types will usually form fruit buds rather than develop side shoots. Spur strains of a variety generally grow only 60 to 70 percent as large as the non-spur strains of that variety.

Characteristics of recommended apple varieties are given in Table 5.4.

Standard trees versus dwarf trees

The two dominating influences on tree size are the rootstock and the type of strain used (spur or nonspur). Other factors influencing tree size include general care, variety, soil type, time and severity of pruning and earliness of fruiting.

Apple tree size, as influenced by rootstocks, is generally divided into three categories: standard, semi-dwarf and dwarf. Standard trees are propagated on seedling rootstock and produce large trees that can grow 30 feet tall.

Semi-dwarf trees are propagated on one of the clonal (vegetatively propagated) rootstocks that produce trees about three-quarters the size of standard trees if both are grown under similar circumstances. The most common semi-dwarf rootstocks used for apples are MM.106 and MM.111.

The interstem tree, a different type of semi-dwarf rootstock, may be available from certain nurseries. These each have a small section of M.9 or M.26 grafted between an understock, such as MM.111, MM.106 and the variety. They are slightly larger than dwarf trees, but smaller than the semi-dwarf. Because they need extra propagation, interstem trees are the most expensive.

Trees on semi-dwarf and dwarf rootstocks are ideal for home fruit production. Although more expensive to buy, the smaller trees are easier to prune, spray, and harvest, and they produce fruit at an earlier age than full-sized trees. M.9 and M.27 rootstocks produce fully dwarfed trees (6 to 8 feet tall and 4 to 6 feet tall, respectively). Both produce shallow, weak root systems and require staking or trellising, and regular watering. Dozens of other size-reducing apple rootstocks exist, but the best for Oklahoma is MM.111, which will produce a tree 25 percent smaller, but very well anchored and drought resistant.

Soil preparation and planting

Before planting, prepare the soil thoroughly by deep cultivation. Have the soil tested and make any recommended adjustments before planting. Information on soil testing can be obtained from the local county Extension office.

High-pH soils are difficult to adjust, but working organic matter into the top foot of soil will help.

Table 5.4. Characteristics of recommended apple varieties.

<i>Variety</i>	<i>Characteristics</i>
Anna	Large, coarse-textured, good flavor
Arkansas Black	Purplish-red with yellow flesh; dessert and cooking
Arkansaw	Red stripes over green; disease resistant
Braeburn	Orange/red blush over yellow; dessert and cooking
Dorsett Golden	Yellow, low-chill; good pollinator for Anna
Enterprise	Sweet and tart; disease resistant
Florina	Pink with white lenticels; disease resistant
Freedom	Red; dessert and cooking
Fuji	Yellow; dessert and cooking
Gala	Orange-red; top-quality eating apple; cider apple, drying, needs thinning; diseases can be a problem
Golden Delicious	Yellow type; russets badly; excellent eating apple where chilling is sufficient for production flavor
Granny Smith	Late-maturing green apple; excellent quality
Honey Sweet	Pale yellow, crisp, sweet; cooking, dessert or sweeten cider blends
Jersey Mac	Early McIntosh-type, crisp red; June to July ripening
Jonathan	Red; dessert and cooking
King David	Red with dark red stripes; crisp, juicy; fresh eating, cooking, and cider
Liberty	Red; dessert and cooking
Lodi	Yellow, soft; cooking only
McLemore	Red; dessert and cooking
Mollies Delicious	Variety similar to Red Delicious; good producer; popular because of production flavor
Orleans	Very sweet and crunchy
Ozark Gold	Yellow delicious type
Pristine	Yellow, disease resistant
Red Delicious	Most popular variety grown
Williams Pride	Very early, large, red-purple; juicy cooking/dessert apple; disease resistant

When bare root apple trees arrive from the nursery, open the bundles immediately, and inspect the trees for damage and general conditions. Soak the roots in water for ½ to 1 hour before planting. Plant the trees while they are still dormant.

When planting, dig holes large enough to receive the roots freely without cramping or bending from their natural position. Use pruning shears to cut off all broken or damaged parts of roots. Set the plants at the same depth they grew in the nursery. Work soil in and around the roots.

When the hole is half filled, firm the soil with your feet; finish filling the hole and again pack the soil firmly. Do not leave a large depression around the tree. Also, do not place fertilizer in the planting hole or fertilize the tree immediately after planting. Fertilizer should be applied only after tree growth begins.

After planting apply enough water to soak the soil thoroughly around the tree roots. Watering eliminates air pockets and brings the soil into closer contact with all sides of the roots. The planting hole may need additional soil after watering.

Training and pruning

The day the tree is planted is the day to begin pruning and training for future production. If neglected, the trees will grow poorly and fruiting will be delayed.

Pruning is cutting or trimming the undesired twigs or branches from a tree or other plant. Training is bringing a plant or branch into a certain shape or position by bending, tying or pruning.

Pruning a young tree controls its shape by developing a strong, well-balanced framework of scaffold branches, which are the primary limbs growing laterally from the tree trunk. Remove or cut back unwanted branches early to avoid having to make large cuts in later years. The modified central leader system is the preferred method of pruning and training non-trellised trees (Figures 5.1 and 5.2). A modified central leader tree has a main trunk and main branches that stair-step up around the central leader. The key is to allow sunlight into the interior of the tree, which promotes the development of short shoots or spurs, where the apples will be produced.

The tree should be headed at 30 to 36 inches when planted. The topmost bud will take over as the leader and grow very vigorously straight up.

The buds in a 4- to 6-inch zone below the top will also be quite vigorous and will usually have poor crotch angles. They should be stripped out when 2 to 3 inches long or spread immediately. Branches below this region will tend to have better crotch angles.

The best time to start establishing good light penetration in a tree is during its first growing season. Scaffold limbs should be selected that have a 60-degree crotch angle and are growing in an outward manner. Apples should have three to five scaffolds in the bottom tier, well distributed on all sides of the tree with the central leader maintained. Scaffold selection should be made early and extra shoots removed.

A second tier of scaffolds is made starting 24 to 30 inches above the first tier. Using semi-dwarf rootstocks such as MM 111, there should be a third tier the same distance above the second.

It is important that these scaffold limbs do not grow straight up. Vigorous upright growth tends to be less fruitful, and it will interfere with the limbs above. If the scaffolds can be made to grow outward, the width of the tree will increase, increasing the amount of light intercepted by the tree. Some cultivars are cooperative in producing wide-angled, spreading limbs; Red Delicious is a notorious exception. Every branch it produces is convinced that its destiny is to become the leader of the tree, and consequently, all grow straight up. Effective management of Delicious demands that mechanical spreading of the scaffold limbs be done to prevent crowding of the branches, shading of the interior and to promote lateral growth and fruitfulness. Once the shape of the tree has been established and the tree is mature, the annual pruning is a matter of removing upright growing shoots, competing shoots and dead wood, as well as shortening any branches growing too tall or wide. Most of the pruning cuts on a mature apple tree will probably be in the top part to prevent shading out of the lower branches.

The problem comes when dealing with an older tree not properly trained when young. You will be confronted with a mass of branches, some weak, others large, probably most with poor crotch angles that are too old and rigid to spread. Resign yourself to not having a picture-book tree, but start pruning to make the most of what you've got.

The general shape of the trees should be similar to an inverted cone: narrow at the top and

gradually widening at the bottom ('Christmas tree' shaped). Remove any dead wood first to make easier access to remaining branches to trim. Take a careful look at the tree and decide which branches to leave for the lower tier and to use as the central trunk. Younger branches may be spread, and older branches can be cut back to an outwardly growing side branch which, if possible, can be spread. Try to leave 6 to 8 inches vertical distance between the chosen scaffolds. Start choosing for the second tier 24 to 30 inches above the first tier, following the same methods as the first tier. These branches will probably need shortening by cutting back to a side shoot. Add a third tier 24 to 30 inches above the second. Remember to maintain the inverted cone 'Christmas tree' shape.

Do not make a lot of fine cuts on the branches that will be kept; save that for next year. A general rule is not to remove more than 1/3 of the wood at any dormant-season pruning. The tree will respond to drastic pruning by sending out vigorous regrowth. Be prepared to deal with it. Vigorous upright growth on the trunk and along the branches will need to be removed either during the summer or at the next dormant season pruning. The best timing for summer pruning in Oklahoma is sometime during August.

Fertilization

Keep the fertilizer 12 inches away from the trunk and broadcast it evenly over the recommended areas. Apply about 1 pound of complete fertilizer per year of tree age (maximum of 10 pounds). When needed (according to fruit set), add 3 pounds of ammonium nitrate per tree in May. The annual terminal growth of bearing trees should be maintained at about 8 inches in length, and fruit spurs should have about eight leaves.

Irrigation

In most areas of Oklahoma, trees need supplemental water for healthy growth. Water young trees weekly; mature trees may require 20 to 45 gallons per day. Mulching may help conserve moisture.

Weed control

Elimination of weed competition around young trees is critical for tree survival and rapid growth. Ideally, the soil surface should be kept weed-free in an area at least as wide as the limb spread of the

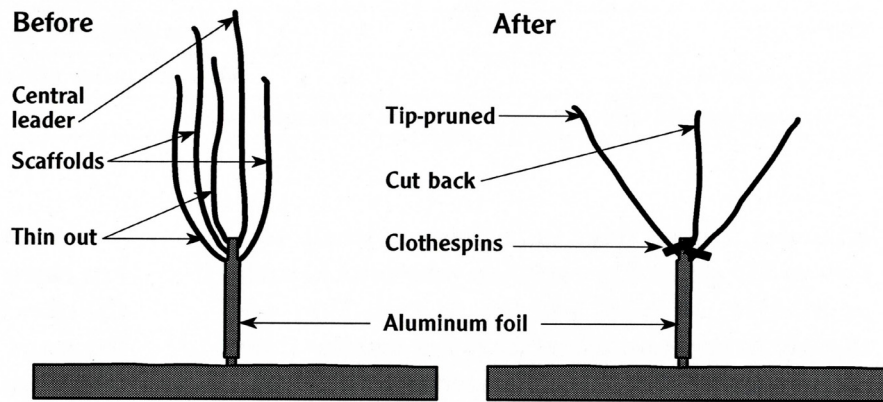

Figure 5.1. Recommended pruning for apple trees during the first dormant season.

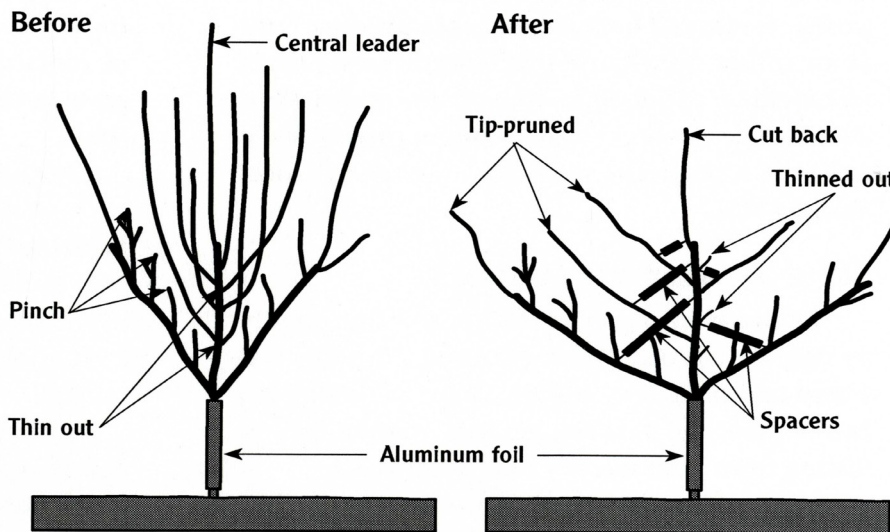

Figure 5.2. Recommended pruning for apple trees during the second dormant season. Prune in late winter. Winter pruning of apple trees consists of removing undesirable limbs as well as tipping terminals (removing the buds at the ends of the twigs) to encourage branching.

tree. Mulches, either organic or fabric can be used to help with weed control and moisture retention.

Chemicals are available that will kill weeds. All aspects of safety and sprayer calibration should be well understood. Glyphosate does a good job of killing weeds and grass because it is systemic and will kill perennial weeds such as Bermuda grass. It will not harm the tree as long as no spray drift hits green leaves or green bark.

Fruit thinning

Apple trees grown under favorable conditions will set more fruit than they can successfully carry to maturity. Removing excess fruit from the trees

ensures satisfactory color, shape and size of the remaining apples. Failure to remove the excess fruit decreases the formation of flower buds for the following year and causes the trees to produce a crop only every other year.

The sooner hand-thinning is completed, the more effective it will be in achieving the desired results. Thinning in mid-summer will improve fruit size and aid in the formation of next year's flower buds. Most of the flower buds for next year are initiated during a four- to six-week period after full bloom; thin them before this period.

Remove the fruit by hand. Leave one apple per cluster, and space the clusters about every 6 inch-

es apart. Start at one end of a branch and systematically remove the fruit. To remove the fruit without damaging the spur, hold the stem between your thumb and forefinger, and push the fruit from the stem with the other fingers. This method removes the apple and leaves the stem attached to the spur.

Caution: Avoid using the insecticide carbaryl or Sevin® shortly after petal fall; it can cause thinning if applied during this period. If you use a general-purpose home orchard mix, check the label for ingredients.

Harvesting

Harvest time varies with individual tastes and location in the state. One person may consider a fruit ripe, while another believes it is immature. However, fruit picked too soon does not develop full flavor or store well.

When picking apples, avoid injuring the fruit; apples picked with the stem attached to the fruit will keep longer.

Remove the apple from the spur by pulling upward and outward while rotating the fruit slightly. On some of the thin, long-stemmed varieties, such as 'Golden Delicious,' it is sometimes necessary to place your index finger firmly at the point of attachment of the stem and spur to prevent breaking the spur.

Disease and insect management

The best fruit is produced when diseases and insects are controlled. Common diseases of apples

to control include cedar apple rust, apple scab, powdery mildew, fire blight, sooty blotch and bitter rot. Summer rots can be particularly devastating to the fruit in a wet year. Damaging insects are scale, spider mites, plum curculio, aphids and codling moth.

Several companies sell home orchard fruit spray mixes to control fruit tree pests. Read and follow all label instructions when applying any pesticide.

Berries

Blackberries

Blackberries are adaptable to essentially all parts of Oklahoma. They are among the easiest and least expensive fruit crops to establish. Good management practices are essential for successful production.

Varieties: Three distinct types of blackberries can be grown in Oklahoma: erect and semi-erect, western trailing (characterized by the 'Boysen' variety), and southern trailing (dewberry). Only certain erect varieties are recommended for production.

New varieties have expanded the season for good-quality berries beyond the traditional May harvest period in Oklahoma. Recommended varieties and new varieties suggested for trial are listed in Table 5.5.

Table 5.5. Characteristics of several blackberry varieties.

<i>Variety</i>	<i>Ripe date</i>	<i>Berry size</i>	<i>Growth habit</i>	<i>Thornless</i>
Apache	Late June to early August	Large	Erect	Thornless
Arapaho	Early June	Medium	Erect	Thornless
Cherokee	July	Medium	Erect	
Cheyenne	July	Large	Erect	
Chickasaw	Early June to mid-July	Large	Erect	
Choctaw	Late June	Very large	Erect	
Kiowa	Late May to mid-June	Large	Erect	
Natchez	Late May to mid-July	Very large	Semi-erect	Thornless
Navaho	Mid- to late June	Large	Erect	Thornless
Osage	Early June	Medium	Erect	Thornless
Ouachita	Early to mid-July	Medium	Erect	Thornless
Shawnee	Early to late June	Large	Erect	

Soils

Well-drained sandy or loamy soils with a pH of 6.0 to 6.8 are ideal for blackberries. Blackberries generally grow well in soils with a pH between 5.5 and 7.5. Soil pH above 7.5 can cause serious iron chlorosis problems.

Planting

If the blackberries are listed as patented varieties, they may not be legally propagated. Non-patented blackberries may be propagated freely. Ask your plant supplier if in doubt.

Erect growing varieties are usually propagated with suckers or root cuttings, while the trailing varieties are propagated by means of tip layers. With blackberry viruses on the rise, tissue-cultured plants often are the best way to buy plants. This ensures clean plants. Both the time of propagation and the time of planting are influenced by the habit of growth.

Erect Blackberries—many nurseries produce plants from root cuttings. The root cuttings, 2 to 3 inches long and 1/8-inch diameter or larger, are planted in the early spring (March). The rows of cuttings should be from 1/2 to 1 inch deep, with cuttings 3 to 6 inches apart in the row. Plants will be ready for transplanting into the permanent row during the following winter.

Another method for increasing plantings of erect blackberries is from naturally occurring sucker plants. One-year-old suckers are dug from established rows and set into new permanent rows (Figure 5.3). More sucker plants can be produced by tilling near existing plants, which breaks the roots and results in generation of new plants from these “cuttings.”

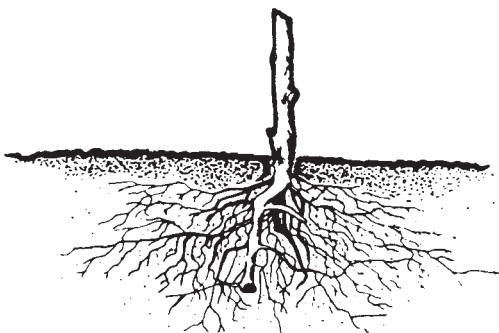

Figure 5.3. One-year-old plant.

Planting may be done at any time during the dormant season, but most planting is done during February or early March. Space plants 3 to 4 feet apart in rows that are 6 to 8 feet apart. Plants should be set at the same depth as grown in the nursery row. Water the newly set plants thoroughly.

Trailing blackberries and semi-erect blackberries do not usually produce suckers or develop from root cuttings. An easy, successful method of propagation is by means of tip layers (Figure 5.4). To tip-layer blackberries, place the tip end of the cane into the soil about 2 inches deep and cover it with soil. This should be done in September or October. Roots will develop during the late fall and winter. Dig the rooted tips during February or early March. Cut the tips from the original canes, leaving a 3- or 4-inch section of the cane attached to it. One established plant may produce from 10 to 20 tip-layered plants each year. The small amount of the cane cut off with the newly rooted layer will not noticeably affect the yield of the remaining cane. Space the new plants the same as erect blackberries.

Growth and production

Blackberries are unique in that they have a perennial root system and biennial tops. The tops (canes) live for two years and die. The first year, they produce vegetative growth (primocanes); the

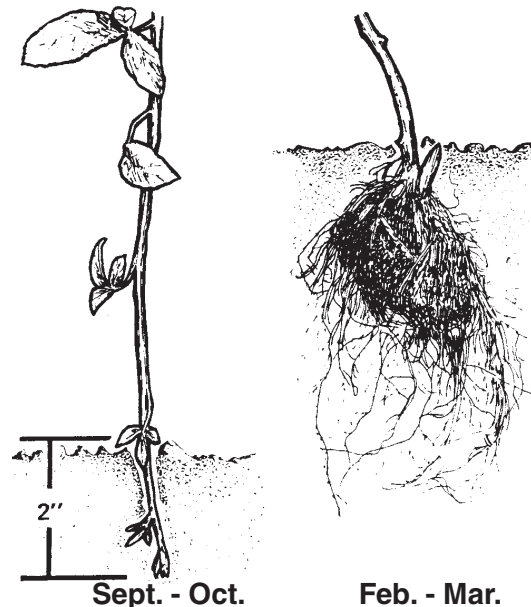

Figure 5.4. Tip layering.

second year, they produce fruit (floricanes). The floricanes die quickly after fruiting.

Blackberries begin bearing one year after they are planted. First-year growth of erect blackberries is low and non-erect. This often causes concern among beginning blackberry growers, but by the second year, all growth is erect. A planting may produce for more than 15 years, but production is usually best during years three through eight, with production decreasing after eight years.

Training and pruning

Erect blackberry varieties are most efficiently trained in freestanding hedgerows. Support wires are not needed. Hedge height is gradually increased during summer pruning to about 4 feet. Hedge width is normally maintained at about 3 feet to enable pickers to reach the berries in the center of the hedge.

Trailing blackberries and semi-erect blackberries need a trellis for support. The trellis may be shaped like an “F” (Figure 5.5) or “T” (Figure 5.6). Additionally, lower wires and crossbars may be added to the “T” to make a “V” trellis.

First-year growth of all types of blackberries, including erect varieties, is low and sprawling. Pruning ends or tipping the primocanes encourages plant growth. Established plants grow new canes while the old canes are fruiting. During the summer, tip the new canes (primocanes), leaving them 42 inches tall (for free standing plants) or at 10 inches above the top of the trellis wire. Tipping

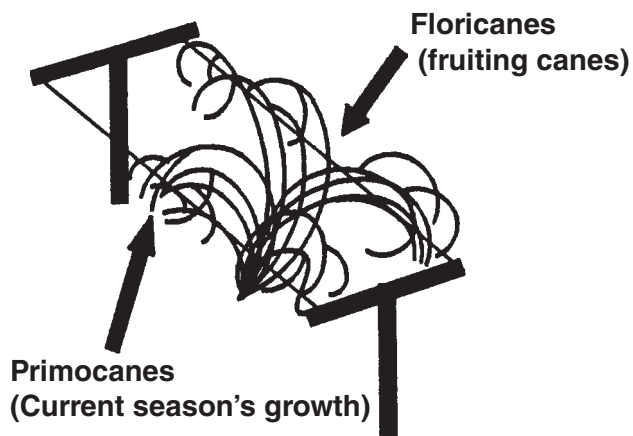

Figure 5.6. T-trellis. All new growth is trained to one side of the trellis, leaving the floricanes on the other side of the trellis, where they were placed the year before.

removes the apical dominance, allowing the cane to develop lateral shoots. Fruit produced the following year from pruned canes will be at a convenient height for harvest. The fruits will be larger, cleaner and better quality than unpruned canes.

Prune out the gray-looking floricanes in the fall. The primocanes are a green to burgundy color. Make the pruning cuts near the crown of the plant, and remove the old canes from the field to decrease insect and disease problems in the future.

After summer pruning, new canes that have produced lateral branches should be pruned again in late winter (February or early March) to simplify harvesting and increase berry size. Shorten lateral

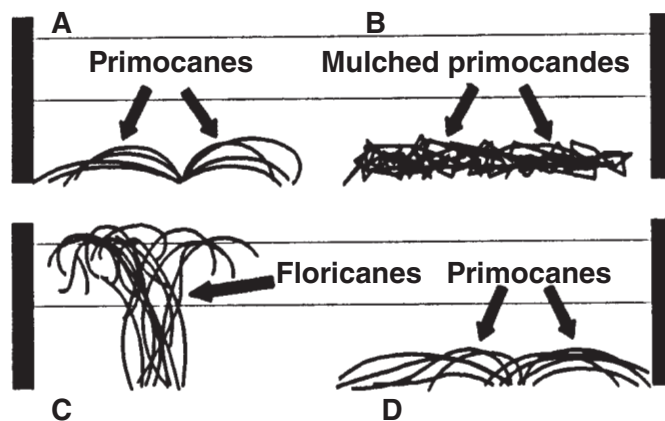

Figure 5.5. F-trellis. A - Primocanes grow during the spring and summer, and are left on the ground under the trellis. B - Mulch can be put over the primocanes in winter to help protect against cold injury. C - After growth begins in the spring, the mulch should be taken off the canes. The canes which have changed to floricanes during the winter should be tied loosely to the trellis wires. D - After the fruit are picked, the floricanes should be removed, leaving the new primocanes under the trellis.

branches to about 12 inches in length. Some new canes will need to be removed during the winter so fruit harvest will be easier the following year. This thinning will also increase air circulation and discourage disease growth. Remove and destroy any canes that have red-necked cane borer swellings to reduce populations. Leave three to five canes per linear foot of row on erect blackberries (Figure 5.7). Leave 8 to 15 canes of 4 to 8 feet in length on trailing varieties, which will be trellised. If not trellising them, reduce to three to five canes. If there are dead canes, that fruited but were not removed during the previous summer, these should be removed.

Fertilization

In good blackberry soils, nitrogen is usually

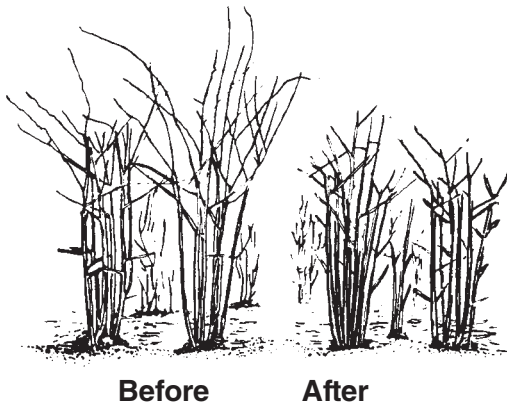

Figure 5.7. Pruning erect canes.

the only serious limiting nutrient. Requirements for phosphorus, potassium and other elements vary in different areas of the state and should be based on soil analysis recommendations and on general knowledge of local soil nutrition. Apply fertilizer to the blackberry plants at bloom to stimulate plant growth, increase berry size and boost total production. A second application of fertilizer should be made following fruit harvest to stimulate vigorous cane growth for next season's production. Apply fertilizer according to the Table 5.6.

Weed control

Good weed control is essential for the survival of first-year blackberries and necessary for good production in mature plantings. Eradicate highly competitive perennial grasses, such as Bermuda grass, before planting.

Several weed-control chemicals are labeled for use around blackberries. Do not use these chemicals unless the applicator is equipped to apply them according to label directions and an accurately calibrated herbicide sprayer.

Mulching

Blackberries should be permanently mulched with about 4 inches of organic material such as pine bark, rice hulls or wheat straw. This mulch will help control weeds, conserve soil and moisture and prevent winter injury to crowns. Mulching also promotes growth of the extensive fibrous blackberry root system. Since the need to cultivate for weed control is reduced by the mulch, fewer blackberry roots are broken, producing fewer unwanted sucker plants between the rows.

Table 5.6. Fertilizer application rates based on nitrogen sources.

	1st Application (oz per plant)	2nd Application (oz per plant)
Actual Nitrogen Required	0.4	0.4
Ammonium Sulfate 21% N	2	2
Sulfur-coated urea 36% N	1	1
Urea 46% N	0.9	0.9
Blood Meal 12% N	3.3	3.3
Cottonseed Meal 7% N ¹	5.7	5.7
Ammonium Nitrate ² 34% N	1.2	1.2

¹ Formulations of cottonseed meal vary; nitrogen content is typically around 7%.

² Regulation of ammonium nitrate is making this fertilizer harder to find.

Irrigation

First-year plants must be irrigated to survive, especially in the central and western parts of the state. Although established blackberry plants are hardy, irrigation is needed to achieve top yields. Water thoroughly immediately after planting. One to two inches of water per week (rainfall and/or irrigation) is needed for good plant growth and quality fruit. Drought severely decreases production and berry quality. However, excess watering can cause the roots of the blackberries to die.

Insects and disease

Spraying/or excluding pests for insect, disease and weed control (Extension Fact sheet CR-6243) is necessary. For anthracnose control in blackberries, liquid lime-sulfur should be applied at 1/16-inch budbreak. An appropriate pesticide should be applied at bloom time to control strawberry clipper. Plants may need to be sprayed during harvest to control the newly introduced Spotted Winged Drosophila. Raspberry Cane and Crown Borers are other major insect pests. For current pesticide recommendations, contact the local county Extension office. The Midwest Small Fruit Spray Guide is a very useful resource for pest control information, <https://ag.purdue.edu/hla/Hort/Documents/ID-169.pdf>.

Harvest

The perishable nature of blackberry fruit requires frequent picking. Softer varieties require harvesting on a two- to three-day schedule; firmer varieties may tolerate a five- to six-day picking schedule, depending on the weather. Use shallow picking containers to prevent mashing the berries. Harvest in the morning when temperatures are cool and refrigerate quickly.

Blackberries become completely black two to three days before they are fully mature. They change from shiny black as they approach maturity to dull black at full maturity.

Blueberries

There are three basic types of blueberries for Oklahoma. They are highbush, rabbiteye and southern highbush. All three grow well in Oklahoma, depending on the location and the cultivar.

Highbush blueberries (*Vaccinium corymbosum*) grow 3 to 23 feet tall and vary in their chilling

requirement from 400 to 800 hours. Chill hours are logged as temperatures between 32 F and 45°F. They generally ripen in May and June and perform best in northern Oklahoma. For best yields, two or more cultivars with overlapping bloom times should be planted together.

Rabbiteye blueberries (*V. ashei*) grow 4 to 19 feet tall and vary in their chilling requirement from 100 to 650 hours. They ripen from late May to early July. They grow best in central and southern Oklahoma and are more heat tolerant than highbush types. Rabbiteye blueberries are divided into pollination groups A, B, C and D. To get the best fruit set and largest fruit, varieties that bloom at the same time should be planted together. Therefore, if a variety is pollination group B, it will be best to plant it near another variety that is also in group B.

Southern Highbush (*V. corymbosum* x with other species such as *V. darrowi*) are intermediate, between highbush and rabbiteye in most respects. Their genetic background is quite variable; therefore, the cultivars vary in adaptability. Southern highbush are somewhat self-fertile, but to increase yield, plant more than one cultivar with an overlapping bloom period. Southern highbush can be grown throughout the state, depending on their chilling requirement and resulting budbreak and bloom time.

Blueberries are an important commercial crop in parts of Oklahoma. Their production is limited to those areas of Oklahoma with acidic, sandy soils. Blueberries also can be grown in containers.

Site selection

Site selection is the most important step in establishing a successful blueberry planting when planting in the ground. Major factors to consider include soil type, soil pH, water drainage, air movement and irrigation water quality.

A blueberry plant's root system is shallow, fibrous and lacks root hairs. Blueberry roots do not penetrate tight, clay soils easily, but require a loose, friable soil environment to develop an extensive root system.

Incorporating organic matter into the soil helps improve soil characteristics, including soil structure, moisture retention and nutrient availability. Sandy soils have a low organic matter content and need peat moss for successful blueberry growth.

Blueberries require a soil pH of between 4.5 and 5.2 and will die if the soil is more acidic or

more alkaline. Adjust the soil pH if it does not fall into the optimum range. Rarely does the pH need to be raised in Eastern Oklahoma. Extreme acidic conditions (less than pH 4.0) can be increased using lime. It is virtually impossible to lower soil pH, so if the soil pH is higher than 5.5, grow blueberries in containers.

It is critical to have the water analyzed before using it to irrigate blueberries. Do not plant blueberries where the water quality is unsuitable. The Soil & Water Testing Laboratory at OSU analyzes water samples for irrigation quality. Local county Extension educators can explain the sampling process, any fees associated with the process and provide necessary information forms.

Blueberries cannot tolerate wet soil conditions. Water tables should not be within 2 feet of the soil surface. The plants must not stand in water for even a week during any part of the year. Sandy soils generally provide good water drainage and soil aeration unless located in a low-lying area. Upland soils are preferred, but lower areas can be used if water and air drainage are adequate.

Varieties

Most blueberries require cross-pollination, and at least two varieties are needed. Cross-pollination is achieved by alternating varieties between rows. 'Tifblue' is self-fruitful and works well in containers. Table 5.7 lists recommended varieties for Oklahoma and average harvest dates.

Early, mid-season and late-season fruiting cultivars can be planted. Ripening dates may vary by as much as two weeks (earlier or later), depending on the weather. Berries will ripen one to two weeks later in northern Oklahoma than in southern Oklahoma.

Planting

February or early March is a good time for planting blueberries in most areas of the state. Plant rabbiteye plants 5 to 6 feet apart, highbush 3 to 4 feet apart and southern highbush 3 to 5 feet apart within rows depending on the vigor of the cultivar. Rows should be spaced to accommodate equipment, usually about 10 feet.

When planting, make sure the holes are about twice the size of the root ball. Add one-third cubic foot of thoroughly dampened peat moss to each hole, mixing it with the native soil. Keep root systems of bare-root plants covered with damp saw-

dust, hay or peat moss while preparing to plant. Do not fertilize until about two weeks later. If bare-root plants are used, one-third to one-fourth of the top growth should be removed at planting time. This balances the plant and helps prevent lodging from high winds. If the root balls of container-grown plants are entwined, loosen them before planting to encourage the roots to grow outward. Plant at the depth they were growing in their pots. After planting, tamp soil around plant to remove air spaces, then water thoroughly.

Irrigation

Irrigation and water quality are of paramount importance in the cultivation of blueberries. A drip irrigation system is recommended. Apply 1 1/2 to 3 inches of water per week. More if conditions are windy. If the root systems are allowed to dry out, the peat around the roots will not re-wet easily, therefore, the plants could die before water becomes available to them again.

The higher rate should be used on very sandy soils, and the lower rate on loamy soils, but will vary according to the weather. Rabbiteye blueberry bushes may be quite large and fruit often ripen after the summer heat has arrived. With conditions of low humidity and dry winds, water needs may be considerably more. If bushes are allowed to dry out between watering, fruit may crack and rot.

Excess water may cause roots or the entire bush to die. Blueberry roots are extremely susceptible to root rot and water-borne pathogens such as *Phytophthora*. Good drainage is essential to excellent blueberry health. <http://www.ces.ncsu.edu/depts/pp/notes/Fruit/blueberryinfo/phytophthora.htm>

Fertilization

Use ammonium nitrogen, urea, sulfur-coated urea, ammonium sulfate or cottonseed meal to fertilize your blueberries. Fertilizer sold for azaleas or rhododendrons also is excellent for blueberries. Apply nitrogen in small applications—at budbreak, bloom, after fruit set, then once a month until August. Giving the plants small frequent fertilizer applications is preferable to large amounts as they have no secondary root hairs and are shallow-rooted. If desired, a slow-release nitrogen formulation could be used and would help prevent excessive losses by leaching.

Table 5.7. Recommended varieties of blueberries for Oklahoma.

<i>Variety</i>	<i>Average harvest season</i>
Rabbiteye	
Alapaha	Early
Austin	Early
Blue Suede	Early
Brightwell	Middle
Climax	Middle
Ochlockonee	Very late
Powderblue	Late
Premier	Middle
Snowflake	Early
Summer Sunset	Early
Tifblue	Middle
Vernon	Middle
Woodard	Middle
Highbush	
Blue Chip	Middle
Bluecrop	Middle
Bluejay	Early
Blue Ray	Middle
Darrow	Middle
Duke	Early
Earliblue	Early
Elliot	Late
Patriot	Early
Reka	Early
Spartan	Early
Southern Highbush	
Legacy	Middle
O'Neal	Early
Ozarkblue	Middle/late
Summit	Middle

Apply fertilizers uniformly around the drip line of the plant, but never near the base of the plant. Fertilizer application stimulates plant growth, increases berry size and boosts total production.

Mulching

Mulching conserves moisture, reduces soil temperature and helps control weeds. Use pine bark, sawdust, rice hulls or other suitable organic materials as long as it is weed free. Apply mulch 4 to 6 inches thick and extend 2 feet on both sides of the plant. Depending on the type, replace the mulch every year or every other year.

Pruning

In a planting established for hand harvesting, limited pruning is required four to six years after planting. Pruning reduces plant height for ease of picking. Thinning out old wood opens up the center of the bushes for improved sunlight penetration. Prune immediately after all fruit has been harvested.

Weed control

Control weeds down the row in an area extending 2 feet on each side of the plant. Use contact herbicides, mulches or some type of mechanical system.

Pest Control

Spraying for insects and diseases may also be necessary. Pay attention daily to the health of your plants. Scout for insects and look for diseases.

Insect pests include:

- Plum curculio is a beetle whose larvae infest fruit.
- Sharp-nosed leafhopper that carries blueberry stunt disease.
- Black army cutworm is a caterpillar that cuts petioles and fruit stalks.
- Flea beetles can seriously damage foliage.
- Bagworms are caterpillars that spin webs and feed inside.
- Blueberry maggots are fly larvae that live inside the fruit.
- Spotted Winged Drosophila, a fruit fly that lays eggs in maturing fruit. Larvae hatch and eat the fruit.

Diseases of blueberries include:

- Stem canker, which may girdle branches. It is controlled by pruning.
- Root rots are controlled by good drainage.
- Blueberry anthracnose is controlled by planting resistant varieties.
- Botrytis blight, or gray mold is partially controlled by pruning and by removal of infected material.
- Mummy berry is controlled by removing infected material.

Harvest

Fruit is ripe when they develop a deep blue-black color. Taste test to determine if it is time to harvest. Harvest in the morning while temperatures are cool, then refrigerate the berries.

Raspberries

Raspberries are grown in many of the northern states, but are not generally recommended for Oklahoma. Fruit quality and yield is generally poor due to spring freezes and lack of heat tolerance. Buds often break during warm periods in January and February, setting the plants up for freeze damage. Using a 50 percent shade cloth or planting next to a building or tree line to block the afternoon and evening sun will help reduce heat stress. There are both primocane and floricanes fruiting types of raspberry. Their culture is similar to trelised blackberries.

Raspberries come in three main colors – red, black and yellow. Purple varieties are a cross between red and black. Varieties can be fall- and summer-fruiting and erect, semi-erect or trailing. Some of the best varieties to try experimentally in Oklahoma are Anne, Autumn Bliss, Boyne, Caroline, Cumberland, Dorman Red, Fall Gold, Heritage, Jaclyn, Jewel, Joan J, Josephine, Magana, Nantahala, Nova and Polka.

Strawberries

Strawberries are challenging to grow commercially in Oklahoma because of their sensitivity to poor quality water and soils, diseases and nematodes. However, strawberries can be grown successfully in a home garden. The most successful plantings have been established using the annual planting system.

When using the annual planting system, the plants are planted in the fall for harvest the next spring.

Planting

For fall planting, cover the bed with black polyethylene film and set the plants through the film in late September or October. Set a double row on each bed with 8 to 12 inches between plants. Water daily until the plants become established.

Fall plantings are usually harvested, then destroyed the following spring. Clip off any runners or flower blooms that form during the winter months. Plants can also be established in containers with well-drained potting soil and slow-release fertilizer.

Irrigation

Irrigation is necessary for good strawberry production. During the growing and production periods, the plants need a continuous supply of moisture. When the leaves begin to wilt, or produce a silver curl in the wind, it is time to water.

Drip irrigation is the common method. However, commercial growers often irrigate newly planted strawberries daily with sprinklers for at least a week to reduce the shock of transplanting. When planting in containers, this is not necessary.

Strawberry plants are sensitive to salt; do not plant them in saline soils. High-saline water can damage strawberry plants and should be used only to keep the plants alive. On soils relatively high in salts, a program of light fertilizer applications should be made with frequent (leaching) irrigation. Excessive irrigation can be harmful, reducing the oxygen supply to the roots and encouraging weed growth. To control weeds, use plastic mulch, straw mulch or hand cultivation.

Fertilization

About two weeks before planting, apply about 1 pound (2 cups) of 15-5-10 (or equivalent) per 25 feet of row. For fall-set plants, apply ammonium sulfate (21-0-0) at 1 teaspoon per plant in December and 2 teaspoons per plant in March. Broadcast the fertilizer over the tops of dry plants and water the fertilizer into the soil.

Harvest

Allow the flowers to set fruit in late January into February. Harvest as needed when the fruit begin

Table 5.8. Recommended June-bearing strawberry varieties for Oklahoma.

<i>Variety</i>	<i>Size</i>	<i>Quality</i>
Allstar	Large	Firm and good
Cardinal	Very large	Good
Chandler	Large	Good
Douglas	Medium to large	Good
Earliglow	Medium	Good
Seascape	Large	Good
Sequoia	Large	Soft, but good
Surecrop	Large	Good
Sweet Charlie	Large	Very good

to color. Remember, birds will try to harvest the crop, too.

Bunch Grapes

Grapes are an excellent crop for Oklahoma home gardens. Grapes can be grown on a trellis or arbor in a wide variety of landscape uses. They are a perfect addition to the garden for fresh fruit, juice, jelly or wine.

Although grapes can grow and produce well in Oklahoma, several serious, limiting factors need to be avoided.

Grape varieties can be divided into three types:

Vitis vinifera - most popular wine and table grapes are derived from a European species of grape. There are more than 5,000 different varieties of these types of grapes including Chardonnay, Cabernet Sauvignon, Riesling, Merlot, Thompson's Seedless and many more. These grapes are marginal for Oklahoma's climate and will only succeed long-term on very good sites. The best areas for these grapes are in the southwest part of Oklahoma.

Interspecific hybrid - grow better in Oklahoma because they tolerate the winter cold and disease pressure better than pure European grapes. Some of the better wine cultivars of these grapes are Vignoles, Chardonel, Traminette, Chambourcin and many more. Hybrid table grapes are also available. The University of Arkansas has released several in the past few years. These cultivars include Mars, Jupiter and Neptune.

American - most famous of these is Concord; however Concord is not well-suited for Oklahoma growing conditions. Other varieties include Cynthiana (also called Norton), Catawba and Steuben, to name a few.

Several hybrid grapes are produced in the U.S. In general, the Vinifera types can have outstanding yields of quality grapes, but have very poor disease resistance and cold tolerance. They demand rigorous attention or the quality will be poor.

Conversely, the American-type varieties have moderate yields and only fair quality at best, but excellent disease resistance and winter hardiness.

The hybrid type varieties are a combination of the Vinifera and American, with good yields and pretty good quality and disease resistance. Select varieties based on how hard you want to work: Vinifera demand much attention; hybrids demand intermediate amounts; and American, much less.

Soils requirements

Grapes can tolerate many different soil types, but prefer a slightly acidic soil (pH between 6.0 and 7.0). A well-drained loamy soil is best, but even poorer soils may help to keep excessive vigor in check. Grapes need full sunlight to induce highest production. A northeast- or east-facing slope is best and the site must have good air and water drainage, as grapes are susceptible to frost and freeze damage and root rot diseases. The ideal conditions for grape production are areas with low humidity, warm summer temperatures and moderate winter temperatures.

Spacing

Place the rows 10 to 12 feet apart and the vines 6 to 8 feet apart. If space is limited, the spacing can be closer. Spacing of vines within the row can vary, depending on trellis system and chosen variety. Sunshine and good air movement around the plants reduces the incidence of diseases.

Selecting plants

Grape plantings should be established using bareroot nursery-grown plants. Even though grapes can be easily propagated from existing vines, movement of plant material can introduce diseases and insects, whereas nursery stock is usually certified to be free from detectable pathogens and insects.

Planting

For best production, make sure the vine will have full sun. Vines should be planted after the frost-free date in the spring if they are growing, but can be planted in February or March if they are dormant. If plants are grafted onto a rootstock, never place the graft union below the soil line when planting because this will eliminate the benefit of using a rootstock. Cut off all canes except the most vigorous one and prune it back to two buds. Trim off broken or split roots.

Dig the hole the size of the root system. Pack the soil tightly, and water immediately with 3 gal-

Table 5.9. Grape varieties for home gardens.

	<i>Ripening Season</i>	<i>Color</i>	<i>Type</i>	<i>Winter Hardiness</i>	<i>Disease Susceptibility</i>	<i>Notes</i>
Table Grapes						
Canadice	early	red	hybrid	good	highly	slipskin, labrusca flavor, medium clusters
Einset	middle	red	hybrid	fair	highly	slipskin, seedless, tough skin
Faith	early	blue	hybrid	good	slightly	non-slipskin, slight fruity flavor
Gratitude	middle	white	hybrid	fair	slightly	non-slipskin, crisp texture, tight clusters
Hope	middle	white	hybrid	good	slightly	non-slipskin, soft fruit, fruity flavor, tight clusters
Joy	early	blue	hybrid	good	slightly	non-slipskin, thin skin, soft fruit
Jupiter	early	red	hybrid	good	slightly	non-slipskin, muscat flavor
Mars	early	blue	hybrid	good	slightly	slipskin, similar flavor to Concord
Neptune	middle	white	hybrid	fair	slightly	non-slipskin, fruity flavor, large clusters
Reliance	early	red	hybrid	good	moderate	slipskin, delicate fruity flavor, some skin splitting
Saturn	middle	red	hybrid	fair	moderate	non-slipskin, fruity flavor, stores well
Sunbelt	middle	blue	american	good	slightly	slipskin, seeded, juice, concord replacement
Vanessa	middle	red	hybrid	good	highly	non-slipskin, seedless, fruity flavor
Venus	very early	blue	hybrid	fair	slightly	slipskin, muscat & labrusca flavors
Wine Grapes						
Baco Noir	middle	blue	hybrid	fair	highly	vigorous, semi-trailing, high acids
Cabernet Sauvignon	late	black	vinifera	fair	highly	vigorous, late budbreak
Catawba	late	red	american	good	highly	table grape, slipskin, spicy flavor, slightly foxy
Cayuga White	middle	white	hybrid	good	slightly	productive, versatile
Chambourcin	late	blue/black	hybrid	fair	highly	large loose clusters
Chardonel	late	white	hybrid	good	moderate	productive, loose clusters, Seyval x Chardonnay cross
Chenin Blanc	late	green	vinifera	fair	highly	tight clusters, vigorous, early budbreak
Corot Noir	late	blue	hybrid	good	moderate	vigorous, productive, cluster thinning needed
Cynthiana	very late	blue/black	american	good	low	small clusters & berries, sensitive to sulfur
Frontenac	very early	blue	hybrid	good	moderate	high sugar and high acid, needs bird protection
Frontenac Gris	very early	white	hybrid	good	moderate	bud sport of Frontenac, used for white wine
Marechal Foch	very early	blue	hybrid	good	moderate	small berry, medium vigor
Merlot	late	blue	vinifera	poor	moderate	large yields, medium fruit size
Niagara	late middle	white	american	good	highly	juice, table, labrusca flavor, large slipskin

Table 5.9. Grape varieties for home gardens (cont'd).

	<i>Ripening Season</i>	<i>Color</i>	<i>Type</i>	<i>Winter Hardiness</i>	<i>Disease Susceptibility</i>	<i>Notes</i>
Noiret	mid-late	blue	hybrid	good	slightly	very vigorous, productive
Petit Verdot	late	blue	vinifera	poor	moderate	medium vigor, small berries
Riesling	middle	white	vinifera	fair	highly	most cold hardy vinifera, moderate vigor, high quality
Rubaiyat	middle	red	hybrid	good	slightly	medium vigor, medium clusters, Oklahoma grape, tintner
Ruby Cabernet	late	blue	vinifera	fair	moderate	late budbreak, small clusters
Sangiovese	late	blue	vinifera	poor	highly	vigorous,
Sauvignon Blanc	middle	green	vinifera	fair	highly	vigorous, mid budbreak
Seyval Blanc	middle	white	hybrid	fair	highly	vigorous, heavy crops, large compact clusters
Traminette	late	white	hybrid	fair	moderate	productive, vigorous
Valvin Muscat	middle	white	hybrid	fair	moderate	small vines, soft fruit, low vigor
Vidal Blanc	late	white	hybrid	good	slightly	large compact clusters, small berries, late budbreak
Vignoles	late	white	hybrid	good	slightly	compact small clusters, late budbreak
Villard Blanc	late	white	hybrid	good	moderate	table, large loose clusters, resistant to Pierce's disease
Villard Noir	late middle	blue	hybrid	fair	moderate	productive, low vigor

lons of water. Do not use potting soil, starter solutions or planting tablets in the hole.

Weed control

Use chemical weed control with a glyphosate-type herbicide. Do not allow the herbicide to contact the trunk or foliage. Weed barriers such as organic mulches can be used.

Cluster thinning

To ensure healthy vine development, pinch off all the clusters in the first two years as they appear.

Training

All grapes need a trellis system for support. Vines will need to be trained to the trellis wires in the first year to begin achieving desired vine form. Many different trellis systems are suitable, but often are chosen because of the type of grape being grown. Extensive pruning is required annually, usually in March just prior to budbreak.

Vines are commonly trained to a high cordon system (Figure 5.8). Grapes fruit only on one-year-old buds. These buds are left on short shoots called spurs.

Fertilizer

As with any fruit crop, a soil test should be done before planting. Any deficiencies in phosphorous, potassium, or pH should be corrected several months prior to planting. Grapes do not require a lot of nitrogen, but potentially could use between 40 and 80 pounds per acre (1 to 2 pounds per 1,000 square feet) of nitrogen per year depending on plant vigor. Starting in the third year of growth, petiole analysis should be used to determine fertilizer application rates.

Irrigation

Water usage of grapes varies greatly, depending on weather conditions. Supplemental irrigation is necessary to keep vines healthy and to keep crop loads full. Irrigation is extremely important during bloom and early growth in the spring. Amount of water to apply will vary with rainfall, but potentially could be as often as three times per week of 8 to 16 gallons per day up to the start of fruit coloring (veraison). Fruit and wine quality may be enhanced with minimal watering in the summer during ripening. Check weather conditions to decide if watering is necessary during this time frame.

Disease and insect management

Black rot is a fungus that is a problem for grape cultivation in most areas of Oklahoma. As growth begins during spring and continues through the summer, fungicide sprays will be needed every 7 to 14 days until veraison (fruit color change). Fungicide sprays will be needed more often during warm, wet and humid weather. Powdery mildew and downy mildew also can be problems requiring fungicides.

Monitor for insects during planting and treat as needed. There are many insects that feed on grapes or grapevines. Insecticides may be necessary, but diseases are more of a concern for growers.

Harvesting

Grapes ripen as early as mid-July. Use recommended varieties to avoid uneven ripening. Birds eat grapes when they are ripe; the birds can also harvest the entire crop unless the clusters are covered with netting or the crop is harvested on time.

Muscadine Grapes

Muscadine grapes are adapted to only the southeastern portion of Oklahoma, south and east of McAlester. According to the 1999 Oklahoma Biological Survey, muscadine grapes are distributed in the four far southeastern counties of Oklahoma (Atoka, LeFlore, McCurtain and Pushmataha). They are cold hardy to about 10 degrees. They have good disease resistance, which makes them particularly suited to the humid climate.

Muscadines are very popular in gardens, on arbors and as screens and borders. Muscadines are unlike bunch grapes because they are harvested as individual berries and may need pollinator vines. They can produce large amounts of fruit, up to 60 pounds per vine.

The highly flavorful fruit of muscadines are particularly popular for jams, jellies, juices and are excellent as fresh fruit. Interest is growing for home and commercial wine production.

Varieties

Most wild vines are male and do not fruit. Many older cultivated varieties are pistillate (female) and require a pollinator. Most of the recently named varieties are perfect-flowered (self-fruitful) and will

also pollinate the pistillate varieties. Recommended varieties are given in Table 5.10.

Most varieties ripen from mid-August through September in eastern Oklahoma.

Soil requirements

Muscadines are best suited to the acidic soils of eastern Oklahoma. They thrive in slightly acidic soils, but are not well adapted to high-pH, calcareous soils. A soil pH of 6.0 is considered optimum.

Muscadines will not tolerate wet feet and should not be planted on soils with poor drainage. If adequate drainage is doubtful, set the plants on a raised row to allow adequate drainage in all directions.

Spacing and planting

Muscadines are planted in the dormant season, usually in February and March. Space the vines 20 to 24 feet apart on 12-foot rows. Dig a hole to receive the entire root system and pack the soil well around the roots. Cut back the top part of the dormant plant to approximately two buds. Start with large, healthy plants about the size of a pencil.

Training and trellising

During the first and second seasons, train muscadines onto a one-wire trellis 5 feet above ground. Set posts every 20 feet, positioning the vines between the posts. Use a small wire or stake to train the young vine onto the wire trellis.

Select one vigorous shoot to grow up the stake and pinch off lateral shoots as they develop. Pinching encourages the development of one strong, upright shoot, which will develop into the permanent trunk. Allow this main shoot to grow upward until it reaches the top wire.

Once it is 5 feet tall, cut the terminal bud out of this shoot to force the development of lateral shoots. Select two lateral cordons at or below the point where they touch the wire and train them down the wire. In some instances, the cordon can develop to the full length of the wire during the second season.

Pruning

Begin pruning muscadines during the third dormant season after the training is complete. Select short, 1-year-old spurs along each cordon. The spurs should be about 6 inches apart, and each spur should be pruned to three buds. Figure 5.9

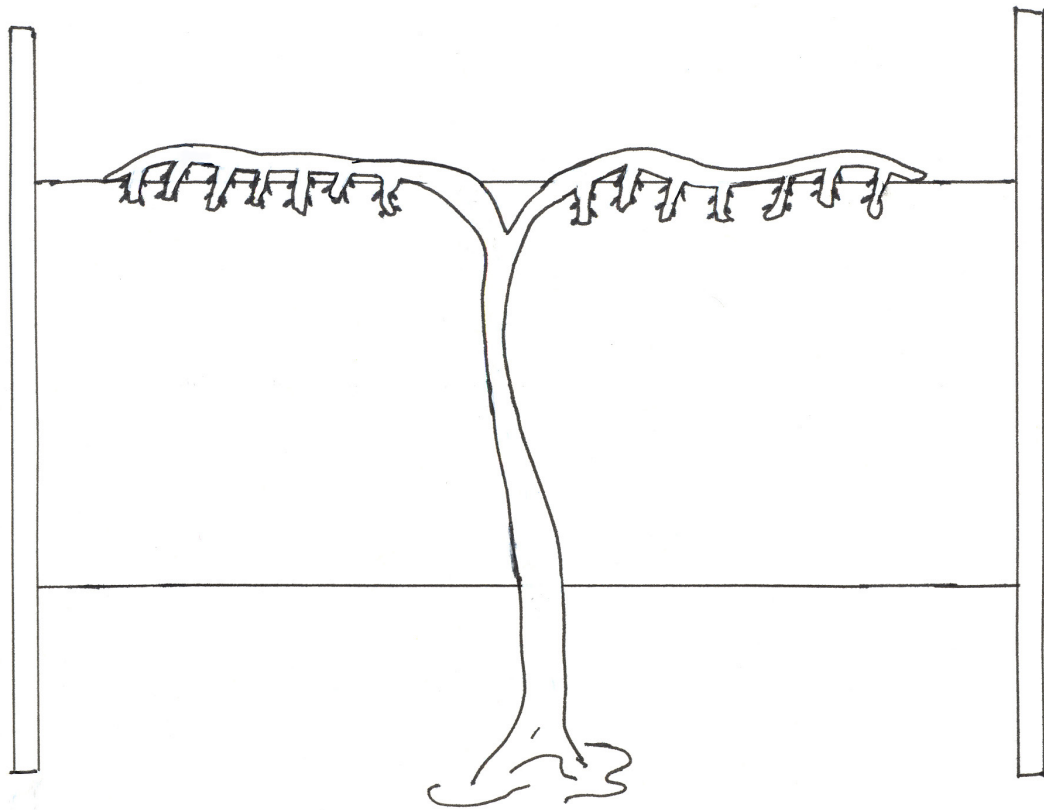

Figure 5.8. High cordon trained vine after pruning.

Table 5.10. Recommended muscadine varieties for Oklahoma.

<i>Variety</i>	<i>Type</i>	<i>Size</i>	<i>Color</i>
Black Beauty	Female flowers only	Very large	Black
Carlos	Self-fruitful	Small-medium	Bronze
Cowart	Self-fruitful	Medium	Black
Fry	Female flowers only	Very large	Bronze
Granny Val	Self-fruitful	Large	Bronze
Ison	Self-fruitful	Medium-large	Black
Jumbo	Female flowers only	Very large	Black
Nesbitt	Self-fruitful	Large	Black
Southern Home	Self-fruitful	Small	Black
Summit	Female flowers only	Large	Pink-bronze
Supreme	Female flowers only	Very large	Black

shows the proper pruning procedure for mature muscadine vines.

Arbors

Muscadines make beautiful arbors (a typical 12-by-12-foot design is illustrated in Figure 5.10). Train the vine up the arbor post the first two years. The third year, establish a cordon down cross-members spaced 24 inches apart.

Prune the cordon to two or three bud spurs every 6 inches before budbreak in March. The cordons should not be closer than 48 inches. If using only one variety, make certain it does not require a pollinator.

Fertilizer

Muscadines respond well to applications of 15-5-10 fertilizers. Unless specific deficiency symptoms are found, no other fertilizer is necessary in Oklahoma.

Apply about 1 pound (2 cups) of fertilizer per year of vine age up to a maximum of 4 pounds. Applications in the first and second years are best applied in four monthly increments in March through June. On mature vines, a single application in February or March is usually adequate. Adjust the fertilizer amounts according to the amount of vine vigor.

Keep the fertilizer at least 18 inches from the vine trunks. Avoid applying fertilizer in sod middles. Where a clean strip is being maintained under the vines, broadcast the fertilizer along the clean strip.

Weed control

During the first year, weeds may be pulled or hoed around the vine. In the second year, kill weeds with glyphosate or glufosinate. Keep the chemical off of the leaves and trunk of the vine. Grow tubes are helpful in keeping spray drift off

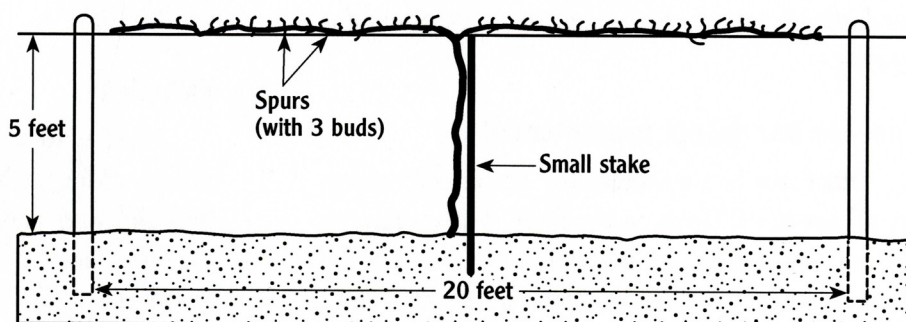

Figure 5.9. A properly pruned, mature muscadine vine.

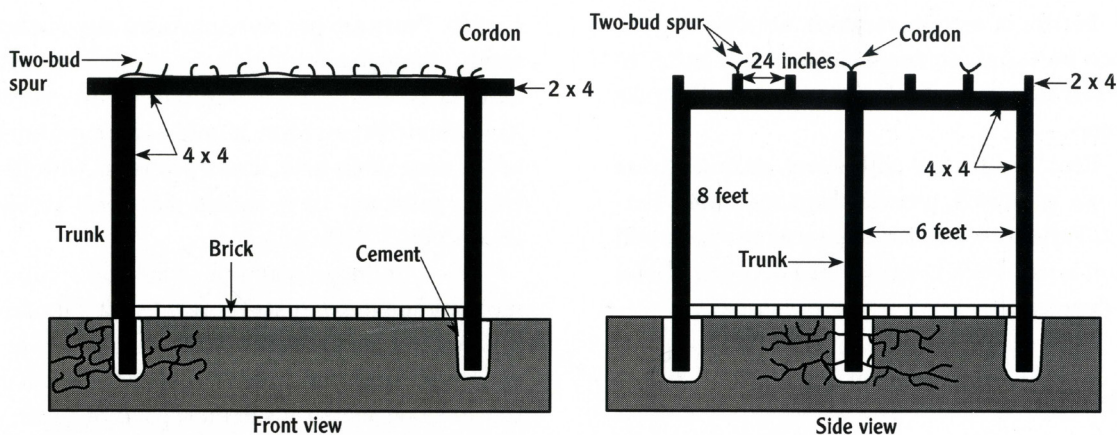

Figure 5.10. A 12- by 12-foot grape or muscadine arbor.

of the trunk surface. Cultivating the soil with a tiller damages shallow roots and may reduce vine vigor.

Pest control

Unlike bunch grapes, muscadines are very resistant to most diseases and nematodes. Because of muscadines' tolerance, they can be grown organically or with limited fungicide applications. Muscadine grapes also can be grown with good success with little or no insecticide applications. Pest monitoring in the vineyard can keep the grower informed of any insect feeding activity to determine if an insecticide application is necessary.

Irrigation

Muscadine grapes are commonly grown in eastern Oklahoma without irrigation, but low summer rainfall often limits fruit size and production. Irrigation is usually essential to establish vines.

Irrigation requirements vary, depending on soil, vine vigor and weather conditions. Adjust the irrigation rates as necessary to compensate for extremes in soil drainage or weather. Reduce irrigations in September or after harvest.

Harvesting

Muscadine varieties ripen from early August through September. Mature fruit are easily dislodged from the vine. Ripe berries can be harvested rapidly by placing a canvas or catching frame under the vine and gently shaking the vine or wire. Harvest every two to five days.

Because varieties with a wet, stem-end scar do not store well, process them soon after harvest. Varieties with a dry stem scar will keep well for at least a week if refrigerated between 34 F and 45 F.

Pears

Pears are long-lived, attractive trees and grow well in Oklahoma landscapes. Select varieties produce good fruit and present few management problems. There are three main types of pears grown in Oklahoma.

The most common is the European pear. These are smooth and sweet with colors ranging from green to yellow to red. European cultivars include 'Bartlett,' 'Bosc,' 'D'Anjou,' 'Magness,' 'Moonglow' and many others.

The second type is the Oriental hybrid. 'Orient' and 'Kieffer' are the two main cultivars, but many more exist. Oriental hybrids are usually considered more adaptable and more tolerant of fire blight than the European and Asian cultivars. Oriental hybrids often have more stone cells and the texture can feel gritty. They are used more frequently in processing than for fresh use, but some newer, improved cultivars have a smoother texture.

Asian pears include many *Pyrus* species. The round shape and sweet crisp flavor has given the Asian pear the nickname of apple-pear. Asian pears include hundreds of cultivars with widely ranging colors, flavors and shapes. Only about a dozen cultivars have been grown commercially in the U.S. A few cultivars grown in the U.S. are '20th Century,' 'Shinseiki,' 'Shinko' and 'Chojuro.' Pears are grown very similarly to apples, but have two additional limiting factors – earlier bloom and greater susceptibility to fire blight.

Fireblight is a devastating disease that appears in the spring affecting blooms, leaves and twigs. The affected tissue turns black and dies and acts as a source of inoculum that can spread to other parts of the tree. Selecting resistant cultivars is the most effective means of control. Fireblight attacks vigorously growing tissue. Try to limit vigor by not applying too much water or fertilizer or pruning in the summer.

Site and soil requirements

Climatically, pears are adapted to all areas of Oklahoma. The more humid eastern portions of the state often have severe problems with fire blight; gardeners there should plant only varieties with high blight tolerance.

Good drainage is an important soil requirement, although pears are more tolerant of poorly drained soil than are most other fruit trees. Sandy soils are best, but garden trees can be grown in clay or heavy loam soils in most parts of Oklahoma.

Plentiful sunlight is a key factor for maximum fruit production. Choose an area of the yard in full sun or nearly full sun. Morning sunshine is particularly important for early drying of dew, thus reducing the incidence of disease.

Pears bloom early, and the blossoms are subject to spring freeze damage, which occurs most often on pears planted in low areas (such as in valleys and along streams).

Buying trees

Use only recommended varieties from reliable sources. Select a healthy, 3- to 4-foot tree with at least a ½-inch trunk diameter. Large trees are often less desirable than small trees because they usually lose more of the root system when dug from the nursery. Larger nursery trees that are two years old or older often lack sufficient buds where side branches should be developed on the lower portion of the trunk.

When buying bare-root trees, be sure the roots are protected. They should be wrapped or covered with a moist medium, such as sawdust or hay to prevent drying.

Pollination

Because most pears are not self-fruitful, two varieties are necessary for good fruit production. Pollen transfer is primarily by insects (mostly bees), so plant trees of different varieties within 40 to 50 feet of each other.

Varieties and rootstocks

European and Oriental hybrid pears are commonly budded to *P. calleryana* (of which 'Bradford' is a cultivar), and selections of 'Old Home' and 'Farmingdale' (OHxF) crosses. *P. calleryana* is drought tolerant and disease resistant. OHxF is highly resistant to fire blight and may control the tree size, depending on the rootstock used. Asian pears are commonly grafted to *P. betulifolia*, a vigorous, well-anchored, drought-tolerant rootstock. Variety recommendations and characteristics are given in Table 5.11.

Soil preparation and planting

Pears should be planted in the fall or early spring, while the trees are dormant. When the trees arrive, inspect the shipment carefully for damage and moisture. Protect the root system from freezing or drying until they are planted in the ground. Trees may be healed in for a short period prior to planting if necessary. Soaking the root system overnight before planting is beneficial. Pear trees can grow to be quite large and should have at least 16 feet or more between trees in each row, and 25 feet between rows. Dig holes large enough to accommodate the root system. Plant the tree at the same depth that the tree grew in the nursery. Backfill the hole with soil and tamp it down to eliminate any air pockets. Water the tree to settle the soil. Do not put

any fertilizers in the hole. Nitrogen fertilizers can be applied after budbreak.

Training and pruning

Pears can be trained in three basic forms: central leader, modified leader and open center. See fact sheet HLA-6257, *Growing and Producing Pears in Oklahoma* for more detailed information for training the different types of pears.

Do major pruning in late winter and prune sparingly in the summer. Remove suckers growing from the base of the trunk as soon as they appear in the summer.

Suckers from *Pyrus calleryana* rootstock are thorny and have leaves that are distinctly different from others in the tree. If not pruned, rootstock suckers often grow to become a significant part of the tree. *P. calleryana* suckers bear tiny, worthless fruit.

On older bearing trees, thin any crowded shoots as needed to allow light to penetrate into the tree. If fire blight becomes a serious problem, prune sparingly, as the vigorous shoots stimulated by pruning cuts are usually more susceptible to fire blight.

Fertilization

Because vigorous growth is more susceptible to fire blight, fertilizer should be applied only in limited amounts. The pre-plant soil test should indicate if deficiencies of phosphorus, potassium and pH problems exist and should be remedied before the trees are in place. If cultivars are susceptible to fire blight, little or no fertilizer should be applied. After growth begins for first year trees, ½ cup of 13-13-13 should be spread in a circle about 6 inches away from the trunk. For the first four seasons, increase the amount by ½ cup each year, continuing with about two cups each year thereafter.

Irrigation

In most regions of Oklahoma, supplemental water is required for optimal tree growth and fruiting. Water young trees at least weekly; although mature pear trees can tolerate drought, they grow and fruit better if they are watered weekly or bi-weekly. Be sure each irrigation thoroughly soaks the soil several inches deep.

Table 5.11. Characteristics of recommended pear varieties.

<i>Variety</i>	<i>Color</i>	<i>Fire blight resistance</i>	<i>Texture</i>	<i>Firmness</i>	<i>Pollination</i>	<i>Uses</i>
European/French						
Bartlett	Yellow	Low	Low	Soft	D' Anjou	Large, canning
Bosc	Dark yellow, russeted	Low	Low	Soft	Partially self-fruitful	Late ripening, high quality
Comice	Green-yellow, light russeted	High	Low	Medium	Moonglow or Maxine	Dessert, too delicate for cooking
D'Anjou	Green-yellow	Low	Low	Soft	Bartlett	Productive, hardy
Moonglow	Yellow, pink blush	High	Low	Soft	Maxine or Comice	Good dessert
Harrow Delight	Yellow, red blush	High	Very low	Medium	Moonglow or Maxine	Smooth, high quality
Maxine	Golden yellow	Moderate	Low	Medium	Harrow Delight or Magness	Fresh, canning, or preserves
Magness	Green-yellow, light russet	High	Medium	Medium	Maxine or Harrow Delight or many Asian	Excellent dessert quality
Seckel	Yellowish-brown	High	Low	Hard	Self-fertile, but benefits from cross	Good dessert quality, sugar pear
Warren	Red-blush	High	Medium	Medium	Self-fruitful	Excellent dessert quality, cold hardy
Oriental hybrid varieties						
Kieffer	Golden yellow, red blush	High	High	Hard	Partially self-fruitful, Orient	Old standard, coarse texture
Orient	Russeted	High	Medium-high	Hard	Partially self-fruitful, Kieffer	
Asian pear varieties						
Chojuro	Green, brown russetting	Moderate	Low	Hard	20th Century, Shinseiki, Hosui	Overbears
Hosui	Golden-brown russet	Moderate	Low	Hard	20th Century, Shinseiki, Chojuro	Butter-rum flavor
Shinko	Brown to golden	High	Low	Hard	Hosui, Shinseiki	Heavy bearer, sweet, juicy
Shinseiki	Yellow brown freckles	Moderate	Low	Medium	Chojuro, 20th Century, Hosui	Good but less flavor
20th Century (Nijisseiki)	Yellow	Moderate	Low	Medium	Partly self-fruitful, Chojuro, Hosui or Shinseifi	Good dessert quality

Weed control

Weeds compete for moisture and nutrients and can limit the pear tree's growth, especially in the establishment years. A weed-free area at least 3 feet from the trunk can be maintained by pre- and post-emergent herbicides or by using mulches. When using systemic herbicides (e.g. glyphosate), use caution to keep any spray or drift off of green tissue. Always read labels of any chemicals used to have knowledge of proper application and safety. Mulches provide both weed and moisture control. Fabric or organic mulches, such as bark or wood chips, allow water penetration and suppress weed growth.

Fruit thinning

Pear trees grown under favorable conditions will overbear, resulting in small fruit and often broken limbs. Remove excess fruit to ensure the remaining pears will develop to satisfactory color, shape and size. If not removed, fewer flower buds will form for the following year, and the trees will produce a good crop only every other year. Over-cropped trees are also subject to serious limb breakage.

The earlier thinning is completed, the more effective it will be. Mid-summer thinning improves fruit size, but does not aid the formation of next year's flower buds, which are initiated during the spring and summer after full bloom. Thin the fruit before this period.

Remove the fruit by hand. Leave one pear per cluster, and space the clusters every 6 inches. Start at one end of a branch and systematically remove the fruit.

To remove the fruit without damaging the other pears on the spur, hold the stem between your thumb and forefinger and push the fruit from the stem with the other fingers. This method removes the pears, but leaves the stem attached to the spur. Pears also can be clipped off with pruning shears.

Harvesting

Determining harvest dates for European pears is difficult and many things should be considered. European pears ripen from the inside out; therefore, if the outside is ready to eat, the inside will be mushy and over-ripe. They must be harvested and allowed to ripen off the tree to develop properly. Several factors must be combined to determine harvest time including: flesh firmness, soluble sol-

ids (sugars), starch development, color changes, ease of picking and days from bloom to harvest. European and Oriental hybrids are picked and ripened off the tree. Flavor and texture can be affected adversely if fruit is not harvested when the fruit changes firmness and color.

Ripening pears

Unlike other fruits, European and Oriental hybrid pears require a period of chilling to ripen properly. Unless this chilling requirement is met, most pears will not ripen, but rather shrivel and rot. This chilling time is cultivar dependent and can range from two days to two weeks. After chilling, pears should be ripened in 65 F to 75 F temperatures with high humidity to develop full flavors. When the flesh below the stem is slightly soft, the pear is ripe and ready to eat.

Storing pears

Because the pear is a climacteric fruit (continues to ripen after harvest), the primary intention is to slow down the rate of respiration and keep the tissue living longer. To achieve this, the fruit should be cooled quickly after harvest and stored at 30 F. If this temperature is not possible, ~35 F in a household refrigerator will extend the life for several months. Storage life depends on cultivar, but fruit of some cultivars will last from three to eight months.

Pecans

The pecan is native to all but about 12 counties in Oklahoma. Pecan trees are quite popular for both their aesthetic value in the landscape and the tasty nuts produced in the fall. Despite their appeal, pecan trees are not care free.

Soil and site requirements

The pecan is native to river and creek bottom soils that are deep, fertile and well drained. These soils also have a large water-holding capacity. It is critical the soil drains well because, contrary to popular belief, pecans do not tolerate standing water.

Pecans can be grown satisfactorily on upland soils that are at least 3 to 4 feet deep. A sandy topsoil underlain with a reddish clay subsoil is best. A friable, red clay subsoil allows air, water and roots to penetrate, but bluish gray to yellow clay hinders such movement and should be avoided.

To successfully grow pecans on shallow soils, thorough eradication of competing vegetation to eliminate competition for moisture and nutrients is required.

Choose planting sites that will receive full sun exposure. Growth will not be satisfactory if pecan trees are planted on sites heavily shaded by other trees or structures.

Buying trees

Nursery trees are available as either container grown, bare root or balled and burlapped (dug with an undisturbed ball of soil around the roots, also called B&B).

Container-grown trees (planted as a seed or small tree and allowed to grow in the pot) are well adapted for landscape planting and can be fall or spring planted. However, container trees cost more than comparable bare root trees.

Bare root trees (dug free of the nursery soil in which they were grown) are the most common. To prevent drying, they must be stored with the roots protected by moist soil, peat or sawdust. The roots must also be protected from freezing.

Nursery trees damaged by root freezing or drying may never grow properly. For easier transplanting and to avoid low-vigor trees, buy bare root trees between 4 and 8 feet tall.

B&B trees are usually large trees used for “instant” landscaping. Large B&B trees require heavy equipment for digging, transfer and planting. Such trees are expensive, but have the advantage of several years of tree growth. However, their use is strongly discouraged in the home landscape. Typically, bare root and/or container trees will outgrow B&B trees.

Buy trees from a reliable nursery source. Avoid bargain trees from outlets not equipped to provide good protection from drying and freezing; ideally, order trees 6 to 18 months in advance to ensure a good variety selection.

Pollination

Cross-pollination is desirable for pecans. To ensure effective cross-pollination, plant early (protogynous) and late (protogynous) pollen-shedding varieties together. Although pecans are pollinated by wind and can cross-pollinate with trees up to a ¼ mile away, ensure consistent pollination by planting the trees within 300 feet of a pollinator variety, native tree or other seedling trees.

Varieties

Because pecans do not “come true” from seed, and every native or seedling pecan tree is a separate entity, there are hundreds of named varieties and literally millions of unnamed pecan varieties.

Pecan varieties differ greatly in nut quality and size as well as in attractiveness as shade trees. Consider your major landscape priority before selecting varieties. General ratings of tree and nut characteristics are given in Table 5.12.

Soil preparation and planting

Plant pecan trees at least 40 feet apart. Trees planted too close together will develop unattractive shapes and will produce few nuts as competition becomes severe.

If the planting site is compacted, thoroughly loosen the soil with a shovel or tiller. A soil test to determine nutrient needs is beneficial. If the soil test suggests a need to adjust pH, phosphorus or potassium, these can be tilled into the soil at planting. Do not add nitrogen fertilizer until after the tree has been planted and started new growth.

Bare-root pecan trees can be planted from February to mid-March in most regions of Oklahoma. It is very important that the roots remain slightly moist, but not wet between nursery digging and planting. If not planting immediately after purchase, heel them in by placing the roots in a trench or hole and covering them with moist soil.

Cut the taproot to 18 inches long. Dig the planting hole 18 inches deep and only as large as the size of the root system (Figure 5.11). Extra-deep holes backfilled with soil allow the tree to settle. When planted too deep, trees that settle in the soil may die or grow poorly. The base of the taproot should rest firmly against the bottom of the hole.

To eliminate air pockets, firm the soil around the roots in 2- or 3-inch layers as the hole is filled. Fill the hole with topsoil from the planting site. Do not fill the hole with sand or potting soil. If light soil is used to fill a planting hole dug in poorly drained clay soil, the soil in the hole may become waterlogged during rainy periods. Extreme soil saturation can damage the roots and often kill the tree.

Plant the tree at the same depth that it grew in the nursery. The soil line on bare-root trees can be determined by bark color. The trunk is gray and the root is dark brown. If the hole is dug too deep and the tree settles after planting, lift the tree to the original soil line before growth begins.

Table 5.12. Common pecan varieties.

Variety ¹	Nut quality ²	Nut size ³	Disease resistance ⁴	Ave. years to production	Comments
Early pollen shedding					
Caddo	4	2	4	6 to 7	Pointed nut; southeast Oklahoma
Giles	2	3	3	7 to 9	Northern Oklahoma
Oconee	4	4	4	5 to 7	Mid Oklahoma
Pawnee	4	3	4	6 to 8	Will overcrop; all Oklahoma
Peruque	2	2	4	7 to 9	Northern Oklahoma
Late pollen shedding					
Colby	2	3	4	7 to 9	Northern Oklahoma
Kanza	5	3	5	7 to 9	All Oklahoma
Lakota	5	5	5	6 to 9	All Oklahoma
Maramec	5	5	4	7 to 9	Mid-Oklahoma

¹ Plant at least one variety from the early- and one from the late-pollen-shedding group to ensure good cross-pollination.

² Based on eating quality, attractiveness, productivity, and nut filling; 5 = excellent, 1 = poor.

³ 5 = large, 1 = small.

⁴ Based on scab on leaves and shucks; 5 = excellent, 1 = poor.

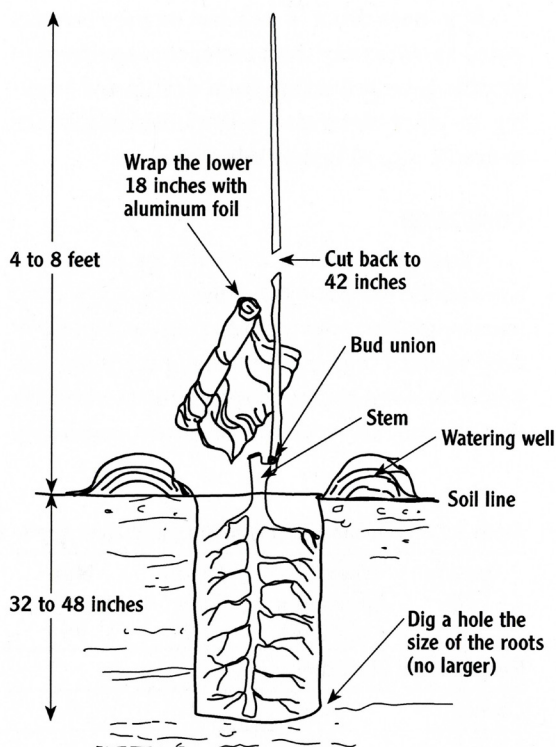

Figure 5.11. Proper planting procedure for pecan trees.

Thoroughly water the tree with at least 5 gallons of water immediately after planting. A 2- to 3-foot-diameter watering well (soil bank) around the tree will help contain the water as it soaks into the soil.

At planting, cut bare-root trees back by half or to 42 inches, whichever produces the smallest tree (Figure 5.11). Container-grown trees can be planted from October through May. Dig the hole to fit the depth of the root system. The root system shouldn't require pruning unless it is curling. If curled, prune back to a straight taproot. The top of a container tree doesn't need to be cut back.

Training and Pruning

Young, grafted pecan trees need to be trained carefully to develop a central leader with strong branches. Untrained grafted trees usually develop many major limbs with weak, narrow-angle crotches prone to split under high winds, ice or heavy crops. Native pecan seedlings tend to form central leaders naturally without training.

For the training to be successful, the young trees must be growing rapidly. Do not train trees that are weak and making little growth until rapid growth is stimulated.

First year: Cut a bare-root nursery tree back to 1/3 to 1/2, regardless of its size at planting.

When new shoots are 4 to 6 inches long, select the uppermost vigorous shoot to be the central leader (trunk). Pinch out the growing point of the remaining (temporary) shoots, leaving them 6 to 10 inches long. Retention of these temporary shoots creates an unkempt, trashy trunk, which aids in the development of a stout, large caliper central leader (trunk) (See Figure 5.12). Repinching of the temporary shoots may be necessary if the tree makes vigorous growth. Growth on the original trunk may be eliminated or maintained at a length of 6 to 8 inches by pinching.

Second year: Side limbs on the original trunk should be treated as temporary, keep them pinched to 6 to 10 inches, while totally removing them during the next two or three years.

Encourage the development of the selected central leader by removing or pinching all secondary branches that may have developed on the central leader during the first summer.

Begin thinking of the height you plan to allow the lowest permanent lateral (scaffold) branch to develop. Scaffold limbs lower than 5 or 6 feet are usually a nuisance, especially when operation of tractors and other equipment is considered.

All lateral growth present on the original trunk and central leader shoot below the desired height of the first scaffold are temporary and should be removed during the next three to five years. Allowing some of this lateral growth to remain during

these early years maintains tree vigor and increases the strength and caliper of the trunk.

To properly develop the central leader, always allow it to be at least 12 to 15 inches taller than any side limb. If the selected central leader made vigorous growth during the first season and is weak, remove one third of its growth to encourage uniform bud break throughout the length of the central leader. This encourages a high percent of these buds to grow into shoots with fairly uniform length during the upcoming growing season.

Maintain continued growth of the central leader by allowing it to be 12 to 15 inches taller than any side limb. Continue to maintain (limit) temporary lateral shoot growth to 6 to 10 inches (Figure 5.12).

Third and fourth years: Lateral branches that are 1 inch or more in diameter and located below the height of the first permanent scaffold branch should be removed. Side limbs selected to become permanent scaffold branches are not headed back unless they are taller than the central leader or are considerably longer than other scaffold branches.

Secondary shoots arising on the central leader during the past growing season usually have narrow angled shoots that may develop near the same locations during the upcoming growing season. Remove any shoots along the central leader with narrow crotch angles. Extremely vigorous central leaders may be cut back by about one-third to en-

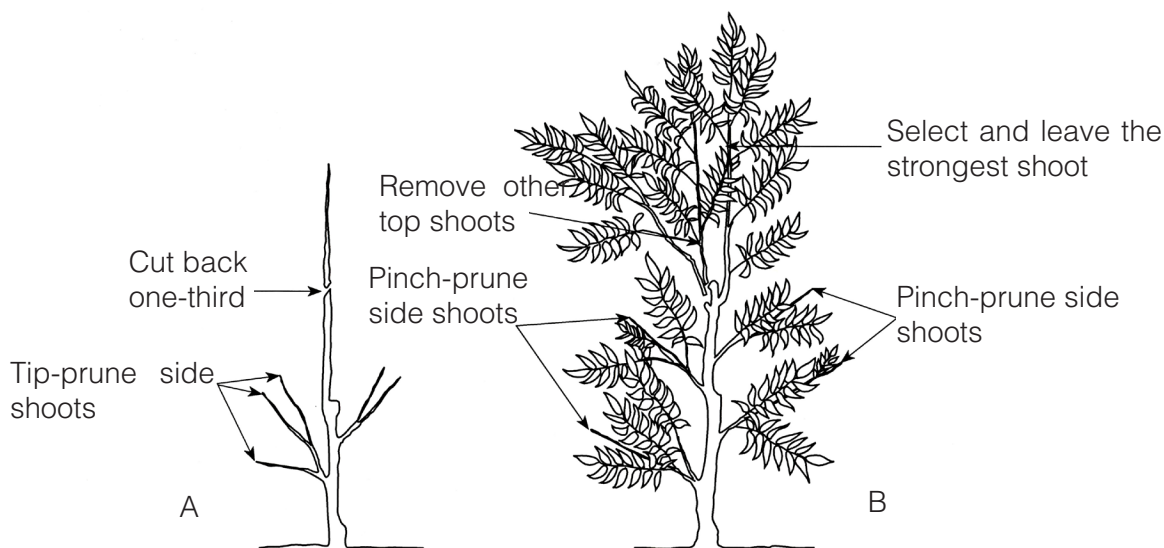

Figure 5.12. Cut back and select pecan tree training the first, second, third or fourth year. A: Dormant pruning in January or February; B: Summer training in May or June.

courage buds to break and develop new shoots (Figure 5.12).

Later years: After the fourth year, the central leader should be tall and strong enough to discontinue the annual cutbacks. Develop the permanent lateral framework of the tree above 6 feet, leaving well-spaced shoots with strong, wide-branching angles from the central leader (Figure 5.13). Where the side shoots are crowded, always remove those with narrow "V" crotches first.

Following these steps will produce a strong, attractive tree with the greatest potential for a long, productive life.

Fertilization

Pecan trees generally require yearly applications of nitrogen and zinc. Unless a soil test indicates otherwise, potassium and phosphorous are usually in adequate supply for pecan trees. Individual trees may be fertilized at the rate of 1 pound of mixed fertilizer per year of age or inch of trunk diameter. Trees 15 to 25 inches in diameter may require two pounds of mixed fertilizer per inch diameter. The rate can be increased to three pounds per inch diameter on trees larger than 25 inches in diameter. Scatter the fertilizer under the canopy of the tree where roots are located.

Foliar-applied fertilizer: Frequent zinc sprays are essential for rapid tree growth. Trees deficient in zinc usually have small, weak leaves; highly branched (rosette) twigs at the shoot tips; and, in severe cases, dieback of twigs and branches.

During the early life of the tree, foliar sprays of zinc every two weeks throughout the growing season (April to mid-July) are ideal. Zinc sprays

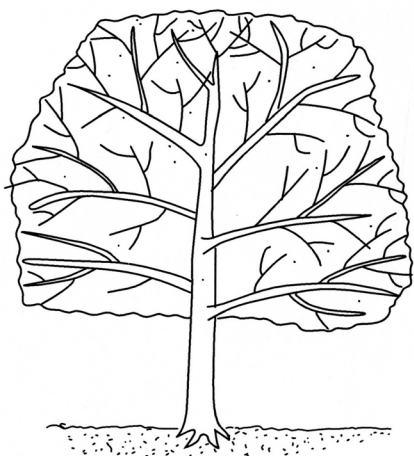

Figure 5.13. A properly pruned, mature pecan tree.

are most effective if applied early or late in the day when there is little or no wind. These conditions allow longer wetting and more zinc penetration.

Spray mature trees with zinc at least three times between bud break (late March or early April) and early June. If the trees are not growing rapidly, spray less often. Use 2 teaspoons Zinc sulfate (wetable powder) per gallon of water or 2 pounds per 100 gallons of water.

These zinc sprays can be mixed and sprayed in combination with most chemicals labeled for insect and disease control.

Irrigation

Irrigation is especially important for young trees. Water after planting, then weekly thereafter if rainfall isn't adequate during the growing season. Producing trees need water at several key times. During the spring for good vigorous growth, from May through July for nut sizing and especially from August to October for nut filling. The late irrigation affects the nut fill, which is important to produce high quality, well filled kernels. Drip irrigation systems work well to provide efficient irrigation to the pecan tree. One to 2 inches of water per week may be needed during the heat of the summer.

Weed control

Weed competition often results in poor growth or even death of young pecan trees. Johnson-grass and Bermuda grass are especially severe competitors, but many other grasses and weeds also cause serious damage.

An area at least 6 feet wide should be kept weed free for the first five to seven years after planting. This can be done chemically or with mulch such as hay, sawdust, bark, leaves, gravel or groundcover cloth. The larger the weed free area, the more beneficial to tree growth and production.

Glyphosate is a broad-spectrum weed and grass killer that must be used with caution to avoid contact on leaves or green bark on pecan trees. Fluazifop-butyl and sethoxydim are selective chemicals that kill only grasses.

Weed control methods and chemicals are listed on the current report [CR-6242 Weed Control in Pecans, Apples and Peaches](#). Always follow label directions carefully when applying any weed-control chemical.

Close mowing will also suppress grass and weeds. Apply more water and fertilizer if a sod cover is grown under the trees.

Harvesting and storage

Pecans are ready to harvest any time after the shuck, which enclosed the nut, begins to open. It is easier to wait and harvest the nuts by shaking or thrashing the branches after the shucks are wide open and partially dried. However, the longer the wait, the more pecans are lost to predators. Squirrels, crows, blue jays, wild turkeys, raccoons and deer can seriously reduce yields.

Nuts harvested early in the season have very high moisture content and must be dried before storage. Dry them in-shell in thin layers on elevated screens or hang them in small mesh bags in a well-ventilated area at room temperature and out of direct sunlight. Within two weeks, the nut meats should be dry enough to readily break when bent, an indication they are ready for storage or immediate use. Nuts harvested after a killing freeze usually require little or no additional drying before storage.

To retain nutmeat quality, store the pecans in the freezer. In-shell pecans will retain top quality for up to 12 months in the refrigerator, but the freezer will ensure much better quality in shelled pecans, perhaps as long as 6 to 10 years. At room temperature, pecans begin to turn rancid after about three months.

Pecans readily absorb odors from almost any odoriferous material, including other fruits and vegetables, so be careful to protect them from possible contaminating odors.

Disease and insect management

Pecans are damaged by several insect and disease pests. Control measures are usually necessary to produce a good crop. For pecan insects, diseases, and control measures, see the Oklahoma Cooperative Extension Service publications available online at osufacts.okstate.edu.

Apply the sprays at the proper times, especially those for the pecan nut casebearer and pecan weevil. Spray dates for these insects may vary each year; check with the county Extension office.

Stone fruit

Stone fruit trees are widely adapted to Oklahoma. However, success in growing fruit trees and in producing quality fruit doesn't just happen. You must pay careful attention to basic management practices, including site selection, variety selection, water and pest management and weed control.

Soil and site requirements

Good soil drainage is essential for growing healthy, productive trees. Soil with standing water or soil that remains saturated for even a day or two after a heavy rain is unsuitable for fruit trees. Instead, grow fruit by planting trees in well-drained, raised beds.

Nutrients such as phosphorus and potassium can be added before planting. Soil pH can also be adjusted prior to planting. Additional information on soil testing is available from the local county Extension office.

Plentiful sunlight is a key to maximizing fruit production. Choose a sunny area. Early-morning sunshine is particularly important to dry the dew from the plants, which will reduce the incidence of disease. If the trees do not receive enough sunlight, their performance will be reduced.

Buying trees

Buy trees from a reliable source; order trees early to ensure the best plants. Bargain plants may not be healthy or they may not be adapted to your area. Ideally, buy 2- to 3-foot trees with good root systems and free of apparent disease problems. A smaller tree with a good root system is more desirable than a larger tree with a poor root system.

Trees grafted to either 'Halford' or 'Lovell' rootstocks tolerate the hot, humid conditions in Oklahoma.

Most fruit trees are sold bare-root. Buy and plant bare-root trees while they are fully dormant, generally from February through mid-March. Although container trees are gaining in popularity, bare-root trees are still reliable and fairly inexpensive. Plant container trees in the dormant season. Remove the soil mix from the root ball and cut the roots if they are circling the container.

Soil preparation and planting

Thoroughly prepare the soil before planting by deeply cultivating and making any recommended adjustments to the soil.

When fruit trees arrive from the nursery, immediately open the bundles to inspect for damage and to check the general condition of the trees. Do not accept trees if the roots appear to have dried out. This is also true for trees bought at a local nursery or garden center.

If not planting them right away, "heal in" the trees by digging a shallow trench and cover the

tree roots or a bundle of trees with moist soil to protect them. Plant in the winter, preferably before mid-March, to allow root development before spring growth. To prevent moisture stress before planting, soak the roots no more than one hour.

Dig the planting hole just large enough for the tree's root system to be spread in a natural position. Avoid digging the hole deeper than the root system, because loose soil beneath the roots usually causes trees to sink too deeply.

Stone fruit trees will develop at least an 18-foot-diameter limb spread at maturity. Plant them at least 20 feet apart to avoid excessive competition.

Set the plants at about the same depth as grown in the nursery. Replace the soil taken from the hole, and firm it around the roots. Do not add fertilizer to the hole.

Thoroughly water the trees soon after they are set. Be sure any air pockets in the hole are filled and the soil is at the proper level on the base of the tree after watering.

Pruning and training

Training begins the year the tree is planted. Prune the newly planted tree about 18 inches to 2 feet above the ground. This will be the location of new scaffold branches. Pruning a young tree controls its shape by developing a strong, well-balanced framework of scaffold branches. The open center pruning system outlined below is best suited for stone fruit trees.

Because most fruit trees bear fruit on wood that grew the previous year, this wood must be regrown from year to year. New growth needs full sunlight, or it will shade out and die. The open center system maximizes light penetration to all parts of the tree, resulting in fruit production through the entire tree (Figures 5.14 through 5.17).

Light pruning can be done any time of year. Major pruning should be done only during the dormant season or in late winter just before budbreak.

Irrigation

Water is essential for producing large fruit and maintaining healthy trees. As long as the trees receive enough water, it makes little difference whether they are watered by drip irrigation, sprinklers or rainfall.

In the heat of summer, provide deep, soaking irrigation at least once a week to maintain healthy

trees. Overwatering can damage or drown trees. Sticky clay soils are especially vulnerable to water saturation and should be allowed to dry for a few days between each watering.

Weed control

For young trees to survive and grow rapidly, it is critical to eliminate weed competition around them. If not, the trees will produce little or no growth and may die. Ideally, keep the soil surface weed free in an area at least as wide as the limb spread of the tree. Glyphosate controls weeds very well. Mulch and weed barrier fabrics can also be used.

Fertilization

Fruit trees can be fertilized (Table 5.13) the first year after they leaf out in spring. Apply fertilizer about 18 inches from trunk in canopy area.

Fruit thinning

Grown under favorable conditions, fruit trees set more fruit than can develop properly. Remove the excess fruit to ensure the remaining fruit will develop well and to prevent limb breakage and shortened tree life from overcropping.

Remove the fruit by hand about four weeks after bloom before the pit hardens. Space the fruit on a branch about every 4 to 6 inches. For larger fruit, space them 8 to 10 inches apart.

Disease and insect management

The best fruit is produced when diseases and insects are controlled. The most serious diseases of stone fruits are brown rot, bacterial leaf spot and leaf curl. Insect problems include scale, plum curculio, lygus bugs and the peach tree borer.

The first line of defense is good sanitation. Remove any old or diseased fruit and wood as it appears. For pesticide spray recommendations for fruits and nuts, see the county Extension office.

Many garden centers sell insecticide and fungicide sprays for home orchard fruit trees. If a product is applied according to label directions, it usually will control most insect and disease pests. Fungicides and insecticides are normally applied every 10 to 14 days from bloom time until harvest.

Peaches and Nectarines

Peaches and nectarines are well adapted to most parts of Oklahoma. Because all peaches

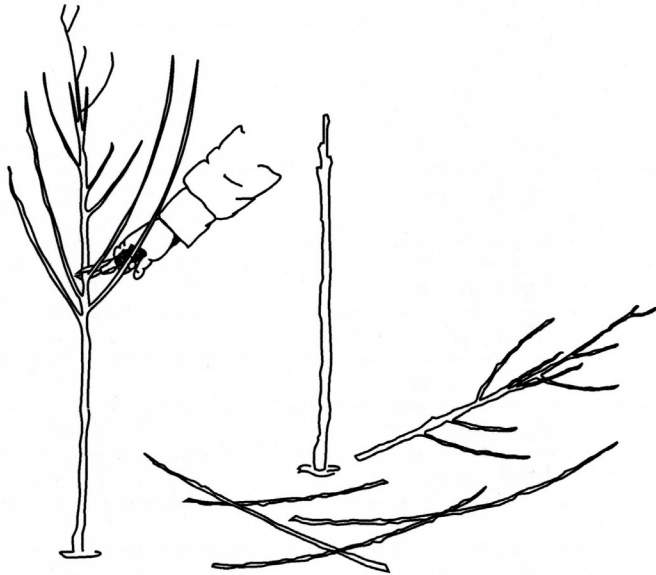

Figure 5.14. At planting, top the tree about 18 inches to 2 feet above the ground, regardless of the tree size.

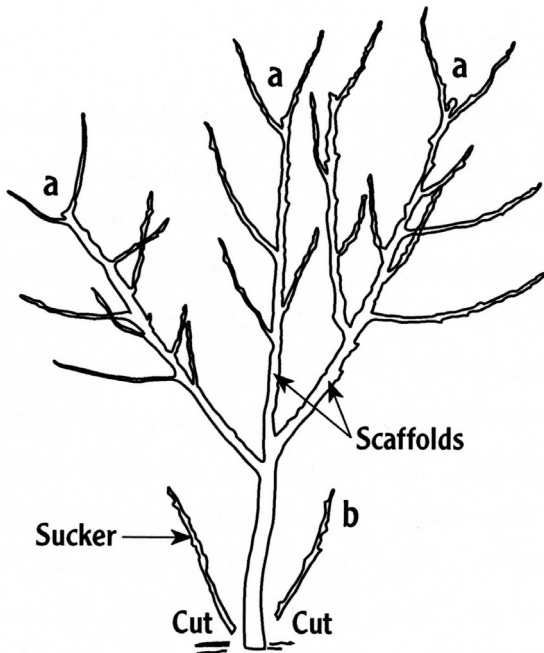

Figure 5.15. Training during the first two years depends on growth rate. (a) Clip the tips on the main branches 18 to 24 inches from the trunk to force the development of the side shoots. (b) Regularly remove suckers. Leave three to five well-spaced, wide-angled branches to form a bowl-shaped framework or scaffold system.

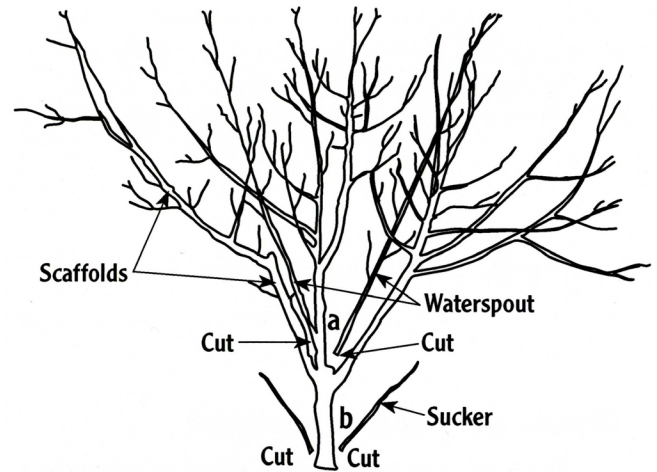

Figure 5.16. Training during years 1, 2 or 3 depends on growth rate. (a) Remove watersprouts (vigorous upright shoots). “Subscaffolds” develop after clipping the tips from the scaffolds. (b) Regularly remove suckers. Remove the larger branches that usually fill the bowl-shaped center of the tree, but leave sufficient, short leafy growth in the center to provide shade protection for the scaffolds.

are self-fruitful, it is not necessary to plant more than one variety. One tree normally supplies more peaches than a single family can consume. The varieties ripening in July and August are normally better quality freestone peaches.

Peaches and nectarines are essentially the same fruit, their primary difference being that peaches are fuzzy and nectarines are smooth-skinned.

Peach and nectarine trees are available as standard trees, which may grow 12 to 15 feet tall if unpruned. The tree size can be easily limited to 7 to 10 feet by conscientious pruning. The flowers normally bloom before the leaves come out in mid-March and range in color from pale pink to dark red. The fruit generally ripens in June through September. Make sure trees are grafted to either ‘Halford’ or ‘Lovell’ rootstocks. These tolerate the hot, humid conditions in Oklahoma. ‘Guardian’ rootstocks are another option for areas that have previously been planted to peaches.

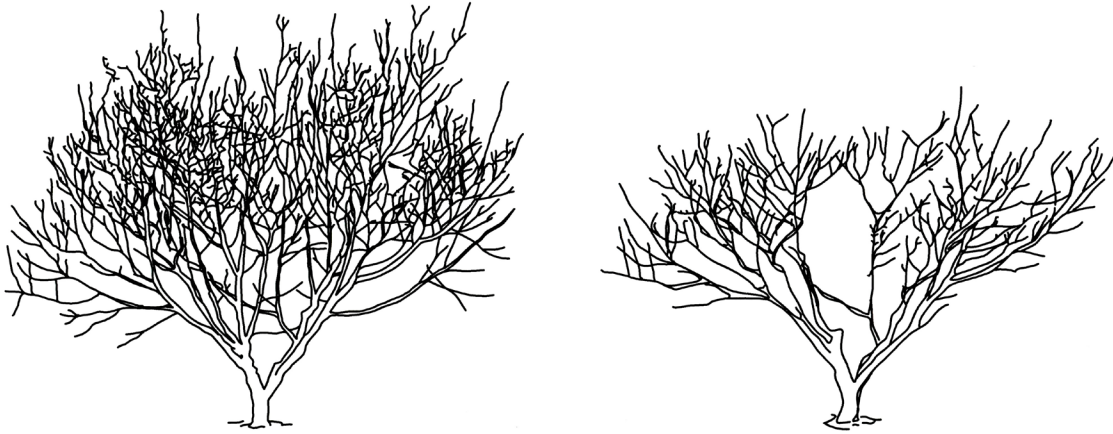

Figure 5.17. Bearing trees. Clip the subscaffolds and other branches to maintain a practical tree height (usually 6 ½ to 7 feet aboveground). Fruit are set on 1-year-old shoots; these must be regrown each year. Thin any crowded shoots that will receive little sunlight. Remove the low branches that may sag to the ground with a crop load.

Table 5.13. General fertilizer recommendations for regularly watered trees.

<i>Development level</i>	<i>Month</i>	<i>Recommendations</i>
Year 1	When growth starts	1 pound of 10-10-10 divided and applied in three applications about two weeks apart
Year 2	March	2/3 of pound of 10-10-10
	two weeks after budbreak	2/3 of pound of 10-10-10
	two weeks later	2/3 of pound of 10-10-10
Year 3	March	1 pound of 10-10-10
	two weeks after budbreak	1 pound of 10-10-10
	two weeks later	1 pound of 10-10-10
Bearing years	March	Each tree may need one pound of complete fertilizer per year of age, depending on shoot growth, (maximum six pounds) divided in three applications about two weeks apart.

Notes: The annual growth of mature peaches and nectarines should be maintained between 10 to 18 inches in length. After the danger of frost is past, it may be advisable to add two to four pounds of ammonium nitrate or its equivalent per tree if a good crop is set.

Plums

General cultural requirements are similar to peaches. The Japanese plum varieties bloom earlier than the European types and are more subject to late spring frost damage. European and Japanese plums should not be depended upon to pollinate each other.

Plums are an excellent tree fruit that can be used in many ways for snacks and family meals. The fruit is suitable for canning, freezing, drying

and preserving into jams and jellies. The trees are hardy and if given reasonable care, can be expected to grow and produce well with growing conditions in Oklahoma.

Types of Plums

Plums are of three different types belonging to the European, Damson and Japanese groups. Of the three groups, the European types are the best adapted for Oklahoma conditions (Table 5.16). European plums tend to be small, and most vari-

Table 5.14. Characteristics of recommended peach varieties.

<i>Cultivar</i>	<i>Ripening Season¹</i>	<i>BLS Resistance²</i>	<i>Flesh Color³</i>	<i>Flesh Adherence</i>	<i>Fruit Quality⁴</i>	<i>Fruit Size</i>	<i>Cold Tolerance</i>
Candor	-2	R	Y	SC	4	Good	Good
Earliglo	-1	T	Y	SF	3	Good	---
Garnet Beauty	-1	T	Y	SF	4	Good	Fair
Rubired	-1	R	Y	C	3	Fair	Good
Sweethaven	-1	R	Y	SF	4	Fair	Good
Early-red-free	-1	T	W	SF	3	Good	Fair
Sentinel	-0.5	R	Y	F	4	Good	Good
Clayton	0	R	Y	F	3	Good	Good
Cullina	0	T	Y	F	4	Good	Fair
Redhaven	0	T	Y	F	4	Fair	Good
Newhaven	+0.5	R	Y	SF	3	Fair	Exc.
Ranger	+1	R	Y	F	5	Exc.	Good
Summer Pearl	+1	S	W	F	3	Good	Good
Glohaven	+2	R	Y	F	3	Exc.	Good
Bounty	+2	T	Y	F	4	Exc.	---
Nectar	+2	T	W	F	3	Exc.	Good
Jayhaven	+3	R	Y	F	4	Exc.	Good
Loring	+3	R	Y	F	5	Exc.	Fair
Biscoe	+4	R	Y	F	4	Good	Exc.
Cresthaven	+4	T	Y	F	4	Exc.	Good
Jefferson	+4	R	Y	F	4	Exc.	Fair
Autumnglo	+5	T	Y	F	4	Exc.	Exc.
Ouachita Gold	+6	T	Y	F	3	Exc.	Fair
White Hale	+6	T	W	F	3	Exc.	Fair
Stark Encore	+7	T	Y	F	5	Exc.	Good
Parade	+8	T	Y	F	4	Good	Good
Flameprince	+8	T	Y	F	4	Exc.	---
Fairtime	+9	T	Y	F	4	Good	Exc.

¹ Seasons: Weeks before or after 'Redhaven.'

² BLS (Bacterial Leaf Spot): R= resistant, T=tolerant, S=susceptible

³ Flesh Color: Y = yellow, W = white; Flesh adherence: C = cling, SC = semi-cling, SF = semi-free, F = freestone;

⁴ Fruit Quality: 1 = worst to 5 = best (3 is acceptable).

Table 5.15. Characteristics of recommended nectarine varieties.

<i>Cultivar</i>	<i>Ripening Season</i>	<i>BLS Resistance</i> ¹	<i>Flesh Color</i> ²	<i>Flesh Adherence</i>
Earliblaze	0	T	Y	SF
Redchief	+2	R	W	F
Cavalier	+3	T	Y	F
Sunglo	+4	T	Y	F
Redglo	+5	T	Y	F

¹ BLS (Bacterial Leaf Spot): R= resistant, T=tolerant, S=susceptible

² Flesh Color: Y = yellow, W = white; Flesh adherence: C = cling, SC = semi-cling, SF = semi-free, F = freestone.

eties are egg-shaped. The flesh is rather dry and very sweet. The European-type plums are best for eating out-of-hand and for canning. Prunes from these plums are the sweetest and easiest to dry. Familiar varieties of the European type are Stanley, Reine Claude (Green Gage) and the French and German prune (Fellenburg) types.

The Japanese-type plums have relatively large, soft and juicy fruit. Although they bloom earlier than the European types and are at greater risk for frost injury, they still grow and produce well in Oklahoma. The red- or maroon-colored, juicy plums sold in the produce section of the local grocery are Japanese-type plums. Examples of Japanese-type plums are Methley, Shiro, Ozark Premier, Burbank and Elephant Heart.

Apricots

Apricots are very ornamental when in bloom, and tree-ripened apricots are delicious, but do not expect consistent production. Apricots bloom early and are usually killed by late spring frosts. Expect a crop one out of four years. One option is to plant dwarf apricots in containers and move them to shelter when blooming in freezing weather.

Contrary to common belief, apricots are self-fruitful and do not require a pollinator. Unfortunately, fruiting is inconsistent on all varieties. The greatest consistency in fruiting is on trees planted near buildings. Recommended varieties are listed in Table 5.17.

Table 5.16. Characteristics of plum varieties.

<i>Variety</i>	<i>Color</i>	<i>Ripe date</i>	<i>Type</i>
Allred	Red skin and flesh	Early June	Japanese
Bluefre	Blue skin, yellow flesh	Early Sept.	European
Bruce	Red skin and flesh	Mid-May	Japanese
Methley	Purple skin, amber flesh	Early June	Japanese
Morris	Purple skin and flesh	Mid-June	Japanese
Ozark Premier	Red and cream streaked with yellow flesh	Late June	Japanese
President	Blue-black skin, yellow flesh	Mid-Sept.	European
Santa Rosa	Purple skin, amber flesh	Late June	Japanese
Stanley	Purple skin, greenish-yellow flesh	Late August	European
Wickson	Yellow skin and flesh	Late June	Japanese

Table 5.17. Characteristics of recommended apricot varieties.

<i>Variety</i>	<i>Fruit size</i>	<i>Color</i>	<i>Ripe date</i>
Blenheim	Medium	Pale orange	Late June
Moorpark	Medium to large	Orange	Mid-June
Royal	Medium	Yellow	Mid-June
Tilton	Large	Orange-red	Late June

Cherries

Sour cherries are generally better adapted than sweet cherries. Many sweet cherries are not adapted to a hot, dry climate. Cherry leaf spot, plum curculio, fluctuating temperatures and poorly drained soils are the major obstacles to successful cherry production in Oklahoma. The diseases and insects can be controlled successfully with a series of sprays. Sweet cherries in general require cross-pollination; but two cultivars, 'Stella' and 'Lapins,' are self-fertile (Table 5.18).

Other Crops

Elderberry

Varieties (Cultivars)

Elderberries are native to Oklahoma and will grow very well where other fruits may not; however, elderberries have limited demand and improved cultivars may be difficult to find. Some of the available cultivars are 'Adams,' 'Johns,' 'Nova' and 'York.' The use of transplanted native plants may be a suitable option if desired cultivars cannot be procured. Since elderberries need cross pollination for fruit set, at least two cultivars (or two different native plants) should be planted.

Soil and Site Conditions

Elderberries can tolerate a wide variety of growing conditions. They do, however, prefer soils high in organic matter that are well drained. Unlike most fruits, elderberries can grow in shady conditions, but must have good air circulation.

Table 5.18. Characteristics of recommended cherry varieties.

<i>Variety</i>	<i>Ripe date</i>	<i>Comments</i>
Early Richmond	Late May to Early June	Standard sour or pie, very consistent
Kansas Sweet	Late May to Early June	Duke cherry (semi-sweet)
Montmorency	Early June	Standard, sour or pie, very consistent
Northstar	Early to mid-June	Sour or pie
Meteor	Early to mid-June	Sour or pie; resistant to leaf spot
Stella	Early to mid-June	Sweet (self-fertile)

Establishment

One-year-old plants are best when establishing an elderberry planting. They are easily propagated by hardwood and root cuttings, but also through layering. Planting should be done after the frost free date in the spring. Plants should be set about 8 feet apart within a row with rows 10 feet apart. When planting, set the lowest branch at, or slightly below, the soil line and water after planting.

Fertilization

Yearly applications of nitrogen are necessary to help elderberries maintain strong growth. Sources of nitrogen to use can be ammonium sulfate, urea, compost or manures. Amounts of nitrogen to apply are not well defined, but as a general rule for one- to three-year-old plants add 1 to 2 tablespoons of nitrogen fertilizers. Older plants should receive 3 to 4 tablespoons of fertilizer annually in the spring. Overall, the amount of nitrogen to add should be based on a visual vigor assessment of the bush. If the bush is very vigorous, producing a lot of new growth, reduce the nitrogen by half or eliminate it altogether.

Irrigation

Elderberries are not extremely drought tolerant, so supplemental irrigation is necessary. Drip

irrigation works well and mulching will also help to conserve soil moisture. The amount of water to apply is not well defined and is tied to soil type, so some trial and error may be needed.

Pest Management

The disease pests found in Oklahoma are not well known. Overall, elderberries are fairly disease resistant. Some of the major diseases include:

- Tomato ringspot virus
- Fungal cankers (various pathogens)
- Powdery mildew (various pathogens)
- Root rots (*Phytophthora* spp.)
- Verticillium wilt (*Verticillium* spp.)

Elderberries may also be susceptible to insects. Some of the possible major insect pests include:

- Aphids (various species)
- Cecropia moth (*Hyalophora cecropia*)
- Elder shoot borer (*Achatodes zea*)
- Stink bugs (various species)
- Sawfly larvae (various species)
- Eriophyid mite (various species)
- Fall webworms (*Hyphantria cunea*)

All grasses and broadleaved weeds should be eliminated before planting elderberries, as they are not competitive with weeds. Mulching will help to control weed populations.

One should consult the local county Extension educator for current and recommended options for control of disease, insect and weed pests.

Harvest

One can expect a small crop in the first year after planting with production in the third year up to 12 to 15 pounds per plant. Eventually, plants may yield up to 12,000 pounds per acre. Harvest of fruit is typically during August and September, but may vary depending on cultivar. Clusters ripen over a period of 5 to 15 days, so multiple harvests may be required. Harvested fruit should be stored at 32 F with greater than 90 percent relative humidity. Roots, stems, leaves, and unripe fruit should never be consumed as they are toxic.

Pruning and training

Elderberry bushes should be pruned to remove weak and diseased canes in the winter.

Roughly six to eight canes per plant should be left after pruning, so some thinning of canes may be needed. Tipping of canes to maintain a desired height may also be needed.

Jujubes

Jujubes have been grown in Oklahoma quite successfully for many years. Jujubes can be used as an excellent dooryard fruit and ornamental for all areas of Oklahoma.

The Chinese jujube, *Ziziphus jujube*, belongs to the Buckthorn family, *Rhamnaceae*. The tree can grow to heights of 30 to 50 feet.

Jujube leaves are dark green and attractive; they are shiny and wax-like on the top and have a layer of white fuzz underneath. The tree loses its leaves in the winter to make an unusually ornate specimen with upright trunks, short-angled shoots and rough bark.

The fruit from seedlings can be quite small; improved varieties can be up to 2 inches long and 1 ½ inches in diameter. As the fruit ripens on the tree in July and August, it will gradually turn from light green to a dark brown and become wrinkled. The fruit is tough and similar to that of an apple.

The seed is hard and shaped much like an olive seed, which is why the jujube is commonly called a Chinese olive.

Varieties

The 'Lang' variety of jujube was introduced into the U.S. from China in 1908. The fruit is large, pear shaped, and red skinned, and it processes well. The tree produces heavy crops. Of all jujubes, 'Lang' remains the most widely grown and propagated variety.

'Li' is a large fruit first introduced from China in 1914. 'Li' ripens later than does 'Lang' and can be eaten straight from the trees; it is the best fresh-eating jujube variety. The flesh of the fruit is crisp and processes well. When fully ripe, 'Li' has a mahogany-colored skin. Many jujubes have a very bland taste.

Soil

Jujubes can grow in most Oklahoma soils that have adequate internal drainage. They can survive on soils that other fruit do not. They perform well in both acidic and alkaline soils.

Climate

Jujubes are extremely well adapted to hot, dry areas and are primarily grown in Oklahoma, Texas and California. In Texas, jujubes have survived drought and excess moisture better than any other fruit.

Although the trees survive in all areas of the state, they appear to be better adapted to more arid areas. In areas where summers are cool, the fruit tends to be of poor quality or sheds prematurely. Winter cold does not appear to be a limiting factor for jujubes in Oklahoma. Because the jujube blooms late, it is seldom damaged by late spring frosts.

Pests

One of the outstanding characteristics of jujubes is they have few insect and disease problems. The only major problems are rabbits and cotton root rot.

Planting

Plant young grafted trees in late winter or early spring before new growth begins. Because they grow upright, the trees can be spaced relatively close and thinned later; space the trees 10 to 20 feet apart.

Dig the hole only large enough to receive the roots and cut off any broken or split roots. Plant the tree the same depth as grown in the nursery.

Young trees can be pruned severely after planting to encourage several lateral scaffold limbs close to the ground similar to other fruit trees. The tree may also be allowed to grow naturally as an ornamental tree.

Root sprouting

Mature jujube trees can develop sprouts from the roots. As the sprouts develop, cut them off at the ground line. Because any root pruning from cultivation will encourage suckering, do not grow jujubes in a lawn or sod environment.

Kiwifruit

Kiwifruit (*Actinidia chinensis*) has drawn increasing interest in recent years because of marketing activities by California and New Zealand, the primary producers of this fruit. High retail prices and some promotion have led many people to

try to grow the vine in Oklahoma. However, most trials have ended in vine death, whether they were grown in research plots, landscapes or aborted commercial endeavors.

Kiwifruit are very sensitive to temperature. In the spring, young growth and blooms can be killed if temperatures go below 30 F. Early-fall temperatures below 27 F can damage the trunks and leaves of young vines, and winter temperatures below 10 to 15 F can kill the entire vine. Because kiwifruit are susceptible to heat injury, some artificial shading may be necessary.

There are male and female plants; hence one of each must be planted. In addition, kiwifruit do best on deep alluvial, loamy soils and very high quality water. As a result, kiwifruit are not recommended for planting in Oklahoma.

Cold-hardy kiwifruit tolerate Oklahoma winters much better, but fail to live through the summer and are not recommended.

Varieties

Actinidia deliciosa is a grocery-store kiwi. It requires a very long growing season, and it is not hardy in Oklahoma. It keeps up to six months in storage.

Actinidia chinensis is closely related to *A. deliciosa*. Selections are being made for hairlessness, fragrance, flavor, and red or yellow flesh. It is a small fruit and is suitable for southern Oklahoma (U.S.D.A. hardiness zone 7).

Actinidia arguta is a hardy kiwi. Small fruit with smooth skin. Keeps two to three months in storage. It produces for 60 years, and bears within three to four years. Plant six to eight females per male. No disease or insect problems. Fruit ripens in late summer.

Actinidia kolomikta is an Arctic kiwi. The male is often used as an ornamental because of the pink and white variegation of its younger leaves. The fruit is small, very sweet, and very cold hardy (-30 F). It has up to 16 times as much vitamin C per unit weight as oranges. The ripe fruit often fall off the vine.

Persimmons

Persimmons are small, easy-to-grow trees that are well adapted to most areas of Oklahoma. The tree, leaves and fruit are free from serious insect and disease problems, making the persimmon

an excellent yard specimen. It requires few or no sprays and is a favorite organic or health fruit.

Mature trees reach heights of 40 feet; persimmon shrubs may be less than 10 feet tall. They produce prolific crops of very attractive fruit during the fall when few fruits are ripe. The fruit is high in vitamin A.

The common American persimmon, *Diospyros virginiana*, grows wild across the south and as far west as the Colorado River in Oklahoma. Trees of American persimmon are very common in abandoned pastures and along fence rows.

This fruit differs markedly from the cultivated oriental persimmon. It is small and very astringent (sour or bitter) until completely ripe. These wild persimmons cannot be eaten until after the first autumn frost and all the leaves have fallen from the tree. Even at this late date, some fruit can still be very astringent.

Wild animals such as possum and raccoon feed heavily on common American persimmon. Persimmon wood is very hard and is used to manufacture golf clubs.

Oriental persimmon, *Diospyros kaki*, was introduced into the U.S. in the late 1800s from China and Japan. It is native to and has been an important fruit crop in these countries for hundreds of years. The fruit is eaten either fresh or dried.

In northern China, certain valleys are exclusively cultivated with Oriental persimmon. On the main island of Japan, groups of these trees grow along the roadside or around farmers' cottages in every village.

Oriental persimmon trees will bear fruit without pollination. Oriental and American persimmon trees will not cross-pollinate. Oriental persimmons may not be winter hardy in northern parts of Oklahoma.

Varieties

The varieties best adapted and most commonly propagated are discussed below.

'Early Golden' (American) is a male variety used for pollination of female types.

'Eureka' is a medium-sized, flat-shaped, red, heavy-producing persimmon of extremely high fruit quality. The tree is relatively small and is self-fruitful. 'Eureka' has proven to be the best commercial persimmon variety.

'Fuyu' ('Fuyugaki') is a medium-sized, non-astringent, self-fruitful persimmon. The fruit is some-

what flattened, red and of high quality.

'Hachiya' is a large, cone-shaped, productive, seedless persimmon with bright orange-red skin. The tree is vigorous and upright. 'Hachiya' has been an outstanding variety. This variety makes an excellent, dual-purpose fruit and ornamental specimen.

'Tanenashi' is a cone-shaped, orange, moderately productive persimmon. The tree is vigorous and upright. The seedless fruit stores extremely well on the tree. 'Tanenashi' makes an excellent landscape ornamental.

'Tamopan' is a very large, flat-shaped, orange, moderately productive persimmon with a distinctive, constricted ring near the middle of the fruit. The tree is the most vigorous and upright of the varieties.

Pollination

Oriental persimmons often fail to produce full crops. This is caused in part by pollination problems and environmental stress.

Male, female, and/or perfect flowers can be produced on the current season's growth on the same tree. 'Hachiya,' 'Tanenashi' and 'Tamopan' produce flowers that develop into excellent parthenocarpic (produced without fertilizing an egg in the ovary) fruit without pollination. These varieties can be pollinated by the common persimmon or the 'Eureka' variety and produce fruit with seeds.

In some varieties, the flesh of the fruit will be darker when seeds are present. Because seedless fruit are preferred, planting only one variety may be desired.

A common problem in parthenocarpic fruit without tree seeds is fruit drop. Any growth problems, such as excessive heat, excessive water, drought or cold can stimulate fruit drop. To prevent early fruit drop, add mulch and manage water carefully.

Harvesting

Persimmons should be fully ripe and soft before eaten; otherwise, they will be astringent. Cold seems to encourage ripening. Some varieties must have a freeze to ripen. Pick the fruit when it is orange and place it in the freezer.

The 'Fuyu' variety is non-astringent and can be eaten as soon as it turns orange. Persimmons will store on the tree for a considerable period.

Pomegranates

The pomegranate is a deciduous shrub or small tree with glossy, dark-green leaves. Native to western Asia, it is now cultivated in warm regions throughout the world.

The fruit, typically bright red, but sometimes yellow, is about the size of an apple, or about 4 inches in diameter. The flesh of the fruit is packed with seeds that scatter when the fruit bursts. The pale yellow seeds are surrounded by a bright red, fleshy coating that has a refreshing subacid flavor.

The pomegranate makes an attractive ornamental with its dense growth habit of dark green leaves and colorful, orange-red to scarlet flowers in early spring. The plant can be grown in just about any soil type that is well drained. If fruit are desired, the plant will need full sun.

The most common variety of pomegranate in Oklahoma has been 'Wonderful.' However, most of the plants scattered across the state are probably seedlings. Seedling plants may be desirable in Oklahoma where cold can be a limiting factor.

Fully dormant plants can tolerate temperatures as low as 10 F. If temperatures are expected to fall below this critical level, some protection may be needed. In most cases though, the plant will resprout from the base even if damaged by cold. Because cold damage is likely throughout Oklahoma, the plant should be left to grow as a bush rather than a tree.

Strictly ornamental types are becoming more common in nursery trade and make pleasant additions to the landscape, but rarely have fruit or the fruit are very small.

Chapter 6: ORNAMENTALS

Learning Objectives:

After completing this section, Master Gardener trainees will be able to:

- Be familiar with the factors important in the analysis of the site and the family needs that when considered results in a well-planned, functional and aesthetical design that fits the site and the families wants and needs.
- Be familiar with the definitions of areas and design considerations.
- Be familiar with the differences between design principles and elements.
- Be familiar with the steps in drawing a landscape plan.
- Be able to discuss several aspects of color in relationship to the home landscape and the design of flower gardens.
- Be able to explain several ways of using flowers in the home landscape plan.
- Understand what the term “flowering annuals” refers to and give several examples of commonly grown annuals.
- Be able to give a general description of soil preparation for planting flowers.
- Be able to discuss starting annual flowers from seed.
- Be able to briefly discuss pest management for flowering plants.
- Understand the life cycle of biennials.
- Be able to explain what “perennial” means, and list some of the advantages of and considerations in growing perennial flowers.
- Understand some of the general criteria for selecting perennials.
- Be able to describe several aspects of cultural management of the perennial flower garden: watering, weeding, fertilizing, etc.
- Know what criteria should be considered when selecting woody ornamental plants for a particular site.
- Understand and be able to apply good planting techniques for woody ornamental plants and understand how using proper techniques can improve survival and accelerate establishment.
- Be able to describe proper follow-up care after woody ornamental plants are installed in the landscape.
- Be able to describe the proper timing, procedures and techniques used in pruning deciduous and evergreen woody ornamental plants.
- Understand the reasons for fertilizing woody ornamental plants and describe the various methods of fertilizer application.
- Know the options for weed management in landscape plantings.
- Be familiar with major problems of woody ornamental plants.
- Differentiate between high and low light levels and discuss methods of providing artificial light for indoor plants.
- Understand the concept of humidity and explain several methods of providing additional humidity to plants.
- Describe several characteristics of a suitable plant container.
- Select and/or mix a suitable growing medium.
- Determine when and how to fertilize indoor plants.
- Explain how and when to water plants and discuss water quality.
- Describe several common methods of propagating indoor plants.
- Recognize some common signs of insect and disease problems of indoor plants and suggest methods of control.

Chapter 6: Ornamentals	170	Watering	233
<i>Part 1: Landscape Design.....</i>	<i>172</i>	Mulching	234
Analysis of Site and Family Needs	172	Wrapping	234
Factors Influencing Landscape Design	173	Fertilizing	234
Definition of Areas and Design		Transporting and Protecting	
Considerations	174	Ornamentals	234
Elements and Principles of Design	176	Ten Tips for Planting and Caring	
Drawing a Landscape Design.....	178	for New Trees.....	
Selection of Plant Materials	180	Care and Maintenance	235
Gardening Practices for		Fertilizing trees and shrubs	235
Sustainable Landscaping.....	182	Mulching	236
Sustainable Landscaping.....	182	Watering the landscape	236
Planning and Design	183	Irrigation systems	238
Xeriscaping	183	Pruning landscape plants	239
Permaculture	183	Pruning techniques	240
Water Conservation	184	Cultural and Environmental Problems	245
Zone Appropriate Plant Selection.....	184	Leaf Scorch	245
Smart Irrigation	185	Drought.....	245
Runoff Management and Re-use.....	185	Winter Burn on Evergreens	246
Soil Conservation.....	187	Injury by Freeze or Frost.....	246
Soil Improvement.....	187	Southwest injury	246
Use of Mulch	188	Winter freeze injury.....	247
Energy Conservation	188	Hail Damage.....	247
Green Roofs.....	188	Ice Damage.....	247
Strategic Shade and Windbreaks.....	189	Lightning Damage.....	248
Reducing Pesticides and Fertilizers.....	189	Damage by misapplied pesticides	248
Reducing Pesticide Use	190	Grade Changes and Construction/	
Reducing Fertilizer Use		Oxygen Deficiency	250
through Composting.....	190	Girdling Roots.....	252
Appropriate Time and Amount of Fertilizing		Mowers and flexible-line trimmers.....	252
Integrated Pest Management.....	190	Sapsucker Damage.....	253
<i>Part 2: Herbaceous Plants.....</i>	<i>191</i>	Selecting Plants for the Landscape	252
Planning the Flower Border	191	<i>Part 4. Indoor Plants</i>	<i>293</i>
Annuals.....	194	Selecting an Interior Plant	293
Biennials	197	Environmental Factors	294
Perennials.....	198	Substrate	297
Bulbs	201	Containers	297
<i>Part 3: Woody Landscape Plants</i>	<i>227</i>	Repotting	299
Plant Selection.....	227	Training and Grooming.....	300
Planting Trees and Shrubs	231	Care of Special Potted Plants.....	300
Pruning and supporting.....	232	Plants Lists	303

Analysis of Site and Family Needs

Landscape developments should provide attractive, useful and comfortable surroundings for their owners and environment. The selection of ornamental plants is categorized into herbaceous ornamentals (annuals and perennials), woody ornamentals (trees and shrubs) and vines/ground covers (which may be herbaceous or woody). The following chapter will discuss factors in selecting plants based on their desired use, environment and associated maintenance practices.

House plants, used to make the interior of the home attractive, also have special growing requirements, which are covered under this section.

Landscape Design

Landscape design can be defined as the art of organizing and enriching outdoor space through the placement of plants and structures in an agreeable and useful relationship with the natural environment.

Merely planting trees and shrubs is not landscaping. Designing a landscape is an art. Landscaping means creating a plan to make the best use of the space available in the most attractive way. It means shaping the land to make the most of the site's natural features and advantages. It means building such necessary structures as fences, walls and patios. Finally, it means selecting and growing the plants best fitting the design.

The smaller the house, grounds and budget, the greater the need for correct and complete planning. Every square foot of space and every dollar must produce maximum results. Plan for the best use of the site and minimum upkeep as well as a pleasant appearance.

Plan for complete development. There is no need to develop all of the lot at once. However, there should be an overall plan, so when any work is done, it will be part of the general scheme. Carrying out the landscape plan is generally a matter of years, for plantings need time to grow. Do not allow a spade of earth to be turned until a grading schedule has been prepared from a well-studied plan for the house and lot. To do otherwise is to sacrifice such things as valuable trees and soil.

Select the proper plants. Subtle differences in plant size, form, texture, color and cultural requirements can make quite a large difference in the landscape.

The fundamental principle of landscape design is that each development should be based upon a specific program, which is based upon:

- The people who will use it, their cultural needs, individual desires and economic abilities.
- The climate.
- The site, its immediate surroundings, topographic and ecological conditions, and all objects, natural and man-made now existing on the site or planned for the future.
- The available materials and methods of fabrication.

The landscaper must study the habits and actions of people, understand their desires and needs, determine what space and materials are available and how they may be used to accommodate these goals.

The first step in landscape design is to divide available space into use areas: the public area, the private area and the service and work area (Figure 6.1). The public area is the section that passers-by view. It is generally in front of the house and should present an attractive public view. The living or private area is for the family and may contain a patio, deck or porch for outdoor sitting, entertaining or dining. A play area may be incorporated, depending on the presence of children. A service or storage and work area should provide a place for garbage, air conditioning unit, garden tools, etc. that is convenient for use, but screened from the other areas. Also included in this area may be a cut flower bed or vegetable garden.

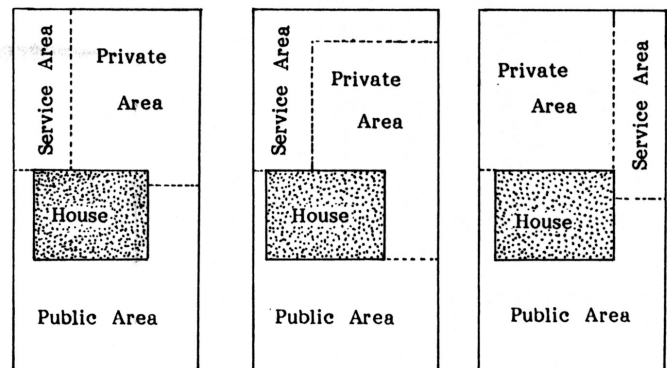

Figure 6.1. Division of landscape into use areas.

Factors Influencing Landscape Design

In laying out a design, preserve all the best natural resources on the site, such as mature trees, brooks, ponds, rock outcroppings, good soil, turf and interesting variations in the terrain. These natural elements affect the ease of construction and landscape possibilities. A careful survey of the area should be made to determine whether site conditions will be a deterrent, or can be incorporated into a design plan. Examples of problems are thin, overcrowded trees that should be removed. Microenvironmental problems may exist on a site, such as low places with cold air drainage or a spot with poor soil and water drainage.

Changes in elevation can add interest and variety to the home landscape. The character of the land, its hills, slope and trees should determine the basic landscape pattern. A hilly wooded lot lends itself to an informal or natural design, with large areas left in their natural state. In such a setting, large trees can be retained.

Although natural slope variations are an asset, avoid creating too many of them artificially. Excess grading of terraces or retaining walls should be avoided. If these features are necessary to facilitate construction or control water drainage, they should be designed to detract as little as possible from the natural terrain.

Keep good views open and screen out the undesirable. Often a shrub or two will provide all the screening necessary. Provide plantings to act as noise barriers. The principal rooms of the house should look out on the lawn or the garden. Design special areas to be viewed from favorite windows.

Climate includes sunlight, all forms of precip-

itation, wind and temperature. All these affect the way a house should be placed on a lot, how the land is used and what is planted. In planning the grounds, don't fight the climate; capitalize on its advantages. In warm regions, enlarge the outdoor living area; in cold regions, plant so the winter scene is enjoyed from the inside. Evergreens and hedges are picturesque when covered with snow. Since people respond differently to sun and shade, it is important to study the amount and location of each on the lot (Figure 6.2). Sun and shade patterns change with the seasons and vary each minute of the day. The sun is highest and shadows are shortest in the summer.

Northern exposures receive the least light, and therefore are the coolest. The east and west receive more light; western exposures are warmer than eastern because they receive afternoon light. The southern orientation receives the most light and tends to be the warmest.

The principal rooms of a house should benefit from winter sun and summer breeze. This means the house must be correctly oriented. A plan suited to one lot will not be correct for a lot facing a different direction. Sunlight and shade can be controlled by the location of buildings, fences and trees. Figure out possible shade from trees and houses on neighbors' lots also.

Plan future shade from tree plantings with great care to keep sunny areas for the garden and summer shade for the house and terrace. Deciduous trees (those that shed their leaves) shade the house in summer and admit the sun in winter. Place trees off the corners (rather than the sides) of the house where they will accent the house, but not block views and air circulation from windows. Remember — over-planting trees tends to shut out sun and air.

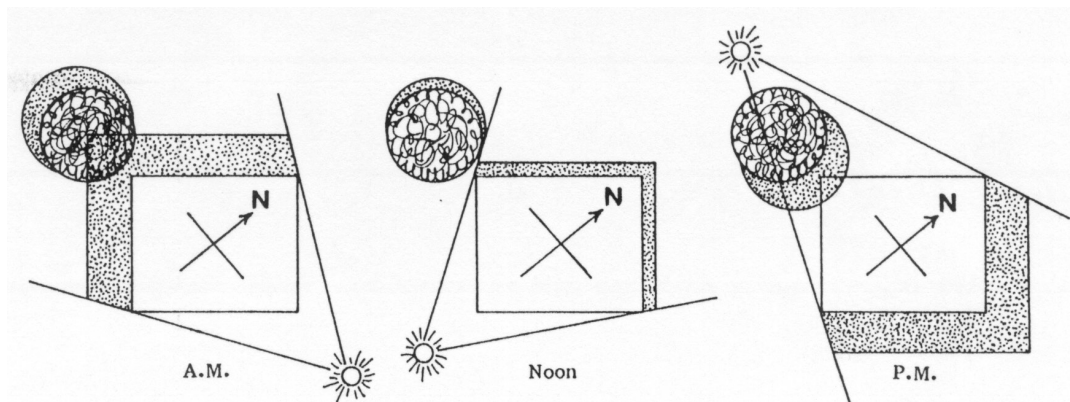

Figure 6.2. Shade patterns at different seasons and times of day.

Use of the land should be a determining factor in landscape design. Analyze the activities of the family. For example, small children need open lawn for playing and gardeners need space for growing vegetables and flowers. Make allowances for future changes. Consider outdoor living, playing, gardening and household servicing. The family routine follows a general pattern, but varies with each family's way of living.

A successful landscape should be able to age and mature with a family. Don't plan a landscape that will remain static, because it will not function as a family's needs change. A plan for a very young family calls for inexpensive plantings. There should be open areas in which children and pets can play. As a family reaches its middle years, more extensive and expensive plantings can be put in. The children's play area can serve other functions; for example, the sand box can become a lily pool. As children grow up, they require less play and less parental supervision -- providing both a place and time for more sophisticated landscaping. With the approach of retirement years, the landscape should become one of low maintenance. Mature trees and shrubs will carry the landscape theme. High-labor areas such as flower beds can be minimized. Ramps may replace steps.

Decide on maintenance standards. For the person who enjoys putting about the yard, the landscape design may be elaborate. However, in general, the simpler the site, the less there is to maintain. A low-maintenance plan is the goal of most homeowners. This may be achieved primarily in the planning stage by careful attention to the nature of the site. Existing trees, elevations and the use to be made of the area should be prime considerations. Low maintenance may be achieved by adopting one or more of the following possibilities:

- Have small lawn areas.
- Use ground covers or natural pine straw, bark chips and other mulches.
- Use paving in heavily traveled areas.
- Provide mowing strips of brick or concrete to edge flower beds and shrub borders.
- Use fences or walls instead of clipped formal hedges for screening.
- Design raised flower beds for easy access and to help control weeds.
- Install an underground irrigation system in areas of low rainfall.

- Have small flower beds. Use flowering trees and shrubs for color.
- Be selective in the choice of plant materials. Some plants require much less care than others.
- Use native plant materials.
- Keep the design simple.
- Use mulches for weed control when possible, but, if herbicides become necessary, use caution and follow directions.

Definition of Areas and Design Considerations

Public Area. The landscape in areas the public sees should create the illusion of spaciousness. Keep the lawn open and keep shrubs to the side and in foundation plantings. When selecting shrubs to frame the front door, consider their texture, color, size and shape so they will enhance the total effect of welcoming guests. Tall trees in the backyard and medium-sized ones on the sides and in front will help accomplish this effect. The house is to be the focal point of the view.

Driveways should be pleasing in appearance, useful and safe. The landscaping of many homes is spoiled by poorly designed and maintained driveways. Some driveways tend to cut up the yard unnecessarily. Parking areas and turnabouts should be provided when practical. If possible, the driveway should be hard-surfaced because it is neater and requires less maintenance than unpaved driveways. Do not plant tall shrubbery at a driveway entrance or allow vegetation to grow so tall that it obstructs the view of the roadway in either direction.

In planning the home grounds, give careful consideration to foot traffic patterns so there will be easy access from one area to another. This traffic may be served by walkways, terraces or open stretches of lawn. In areas of heavy use, paved surfacing material is best.

Design of the walk system to the front door will often depend on the location of the front door and guest parking, as well as the topography of the land. If guest parking is at the edge of the street, a straight walk is probably best if the grade is suitable. When the guest parking area is planned for the property, the walk might more logically lead from the guest parking area to the front door. Foot traffic can use the driveway.

Sometimes the topography of the land will make it desirable to have the entrance walk start at the edge of the property and curve to the front door to take advantage of a gradual grade. However, avoid curved walks that have no apparent reason for curving.

Generally, the walk to the front door parallels the house and joins the driveway. This design is sometimes used if the driveway entrance grade at the street is less steep than the area directly in front of the door. This type of design might eliminate the need for stairs. When the walk is parallel to the house, be sure sufficient space is left for plant material.

For a residence, make the front walk at least 4 feet wide. Build walks so they are safe. Avoid using materials that are rough or raised, since it could pose a tripping hazard. Design steps so they will be safe, especially in wet or icy weather. Make the treads wider and the risers shorter than the treads and risers used indoors. Install handrails where needed.

Private or Outdoor Living Area. The private living area or outdoor living room has become an important part of the American home. No yard is too small to have a private sitting area where family and guests can gather. Where possible, there should be easy access from the house to the outdoor area. The ideal arrangement is to have the living room open onto a porch or terrace and/or have the kitchen near the outdoor dining area. The outdoor living area can be simple. An open, grassy area enclosed by a wall or shrubs enables the homeowners and guests to sit outdoors in private. A more elaborate outdoor living area can be developed by introducing a series of gardens or garden structures. The outdoor private area can serve the following functions:

- outdoor entertaining,
- family relaxation,
- recreation,
- outdoor eating and
- aesthetic enjoyment.

The following are guidelines to consider when planning major private areas:

Privacy: The area should be enclosed from public view or nearby neighbors. Properly grouped shrub borders and trees will do this. For a small area, use a fence to save space. The private area should be screened from work areas, such as

clotheslines, wood piles, garden sheds and other less pleasant views.

Livable touch: Furniture should be attractive, designed for outdoor use and appropriate for the size of the landscape. Garden accessories should be kept to a minimum and be simple and unobtrusive.

Year-round interest: The outdoor living area should be planned so the selection of plant material is varied and there is interest throughout the year. This is especially true if the area is visible from the house. For winter interest, select shrubs and trees with colorful bark, evergreen foliage or colorful fruit. During the rest of the year, use flowers, shrubs and trees to create interest. Pools, stone steps, paving, walls, bird feeders and other architectural features will add interest to the garden. Architectural details do not change with the seasons and give interest and meaning to the garden throughout the year.

Climate control: Control of weather in the outdoor living area helps to extend the period of usefulness. Shade trees screen the area from the hot sun. Windbreaks cut down some of the wind in the fall. An awning or lattice roof can protect against inclement weather. A garden pool or fountain can convey the effect of coolness during the hot summer season.

The terrace or sitting area: The center of activity for a living area is often a space arranged with garden or patio furniture. It may be a porch, deck or terrace next to the house or the special section of the living area. This latter area might be under the shade of a large tree or in a shady corner. The sitting center may be either paved or in turf. Flagstone, brick, concrete blocks or concrete are materials commonly used for surfacing the outdoor terrace. The size of the paved terrace depends upon its expected use and the type and amount of furniture desired. An area 10 feet by 10 feet will hold four chairs and is about the minimum size for accommodating four people comfortably. Increase the size for a picnic table if desired. This area may also include a grill or outdoor cooking area.

The play area: The play area can be a part of the outdoor living area or separate from it. For very young children, a small area enclosed by a fence near the kitchen or living area is desirable. A swing, sand box or other equipment can be placed here. In yards with a good deal of open lawn space, there is room for croquet, badminton or a portable

wading pool. A large tree in the back yard may be ideal for a tree house. A paved driveway or parking area makes an ideal area for basketball or other games for older children, as well as tricycling or rollerblading for younger ones. Since children in a family are always growing, it is necessary to make design adjustments to meet changing recreational needs.

Enclosed front yard as a private area: The area in front of the majority of homes has traditionally been left more or less open so the passing public can view the home. Plantings, such as hedges or a screen planting of trees and shrubs along the street to make the public area private, have been used to provide privacy for the front area. Privacy in the front yard may be desirable when a picture window faces the street or when the front yard is used for outdoor sitting. Where space is limited, a tall attractive fence may provide privacy and be used as an attractive background for shrubs and smaller plants.

Service, Work or Production Areas.

Space often needs to be provided for permanent objects such as garbage cans, air-conditioner units, tool storage, wood storage, vegetable garden, compost, cold frame, small greenhouse or kennel. Service facilities should not be visible from the outdoor living area or from the street. However, an exception might be an attractive greenhouse or tool storage building designed and constructed so it blends well into the overall setting and with an interesting composition of plant material around it. Wood or wire fences, brick or masonry walls or plant material alone or in combination are the materials most commonly used to hide or screen service areas.

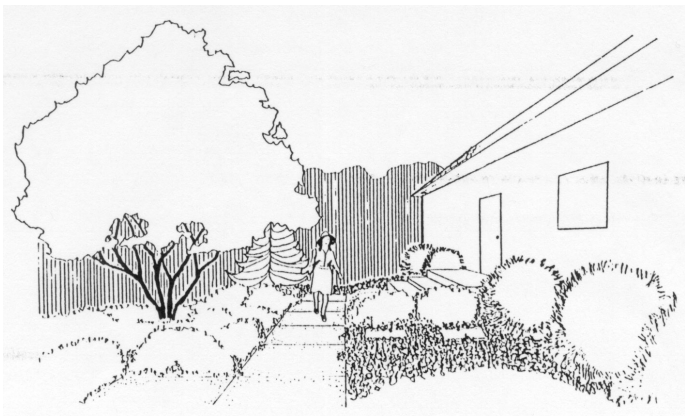

Elements and Principles of Design

There are no hard and fast rules for landscaping, since each design is a unique creation. Landscaping, as in all art forms, is based on certain elements and principles of design, which are discussed here.

Scale. Scale refers to the proportion between two sets of dimensions. Knowing the eventual or mature size of a plant is critical when locating it near a building. Plants that grow too large will overwhelm a building. Small plantings around a large building can be similarly inappropriate. It is essential, therefore, to know the final size of a particular plant before using it in a landscape. Both the mature height and spread of a plant should be considered.

Balance. Balance in landscaping refers to an aesthetically pleasing integration of elements. It is a sense of one part being of equal visual weight or mass to another. There are two types of balance -- symmetrical and asymmetrical (Figure 6.3). Symmetrical balance is a formal balance. It has an axis with everything on one side duplicated or mirrored on the other side. Asymmetrical balance is balance that is achieved by using different objects

SYMMETRICAL BALANCE



ASYMMETRICAL BALANCE



Figure 6.3. Examples of balance.

to achieve equilibrium. For example, if there is a very large object on one side of a seesaw, it can be counterbalanced by using many objects of a smaller size on the other side of the seesaw or one object of equal size. In each instance, balance is achieved. This applies to landscaping when there is a large existing tree or shrub. To achieve visual equilibrium, a grouping or cluster of smaller plants is used to counterbalance the large existing plant. Balance may also be achieved through the use of color and texture.

Unity. A garden with too many ideas expressed in a limited area lacks unity. Too many showy plants or too many accessories on the lawn would claim more attention than the house itself. Using too many accent plants or plants with contrasting textures, form or color violates the principles of unity. To achieve unity, it is necessary to group or arrange different parts of the design to appear as a single unit. The design should be pleasant from every angle.

Rhythm. Rhythm is a repetition of elements directing the eye through the design. Rhythm results only when the elements appear in regular measures and in a definite direction. Rhythm can be expressed in color as well as form.

Simplicity. Every square foot of landscape does not have to have something in it. Objects such as bird baths and garden globes are often overused in the landscape. There is a design concept expressed as "less is more." This statement is especially true regarding landscape design. Keep the landscape simple and it will look its best. Avoid cluttering the yard with unnecessary objects. This includes plant material, statuary and miscellaneous objects. When too many extras are introduced, the yard takes on a messy appearance. Use statuary or specimen plants with discretion. The simplest landscapes are often the most attractive. Remember -- create spaces, don't fill them up.

Accent. Accent, also referred to as dominance, focalization or climax (Figure 6.4), is important in the total picture. Without accent, a design may be dull, static or uninteresting. Various parts, if skillfully organized, will lead the eye toward the focal point. This may be a garden accessory, plant specimen, plant composition or water in some form. Emphasis may also be obtained through use of contrasting texture, color or form or by highlighting portions of a plant composition with garden lights.

ACCENT



Figure 6.4. Example of accent, in which all elements lead the eye to the focal point, the house.

Repetition. Do not confuse repetition in the landscape with monotony. A row of sheared hedges lined up in front and down the side of a home is not repetition; it is monotony. Repetition is something more subtle. For example, the use of curves in the landscape design; curves may begin in bed lines in the front yard, continue in the side yard and be picked up once more in the backyard. Alternatively, the repeated use of right angles on a grid design can successfully be used to achieve unity in the landscape. The right angles may begin in the front yard, perhaps on the sidewalk, then be used in the bed lines which go around the property and be picked up again in the backyard. By subtly repeating such design elements as bed lines in the yard (Figure 6.5), one can achieve continuity or flow to the entire landscape.

Harmony. Harmony is achieved through a pleasing arrangement of parts (Figure 6.6).

REPETITION



Figure 6.5. Example of repetition.

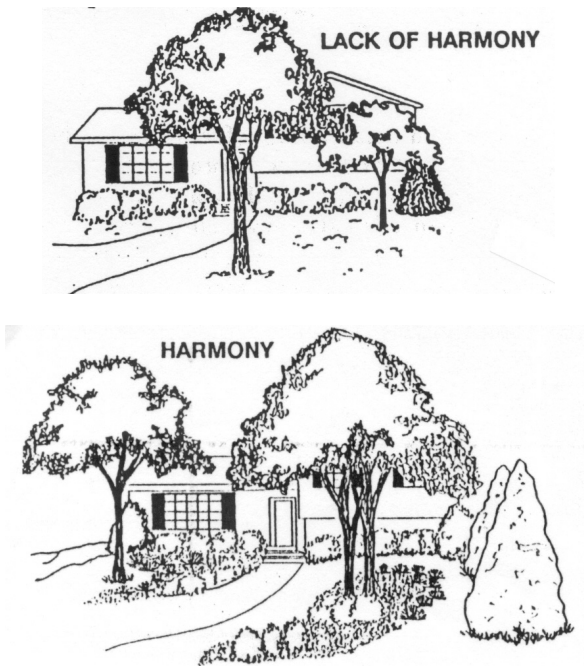

Figure 6.6. Lack of harmony versus harmony.

Drawing a Landscape Plan

The following section provides the information necessary to draw a landscape plan that embodies the elements of good design. These steps are for those who want the fun and satisfaction of preparing their own landscape plan. They are:

1. Preparing the map.
2. Deciding how the ground area is to be used.
3. Placing use areas on the map.
4. Developing the landscape plan.
5. Preparing a planting plan.

Completing these steps will enable you to develop a final plan that can be implemented over several years as time and money permit.

Step 1 – Prepare a baseline map. Prepare a scale map of the home grounds (Figure 6.7). Use graph paper and let one square equal so many feet, or draw to scale using a ruler or an engineer’s scale.

<i>Suggested Scale</i>	<i>Small Lot</i>	<i>Large Lot</i>
Engineer	1 inch equals 10 feet	1 inch equals 20 feet
Ruler	1 inch equals 8 feet	1 inch equals 16 feet

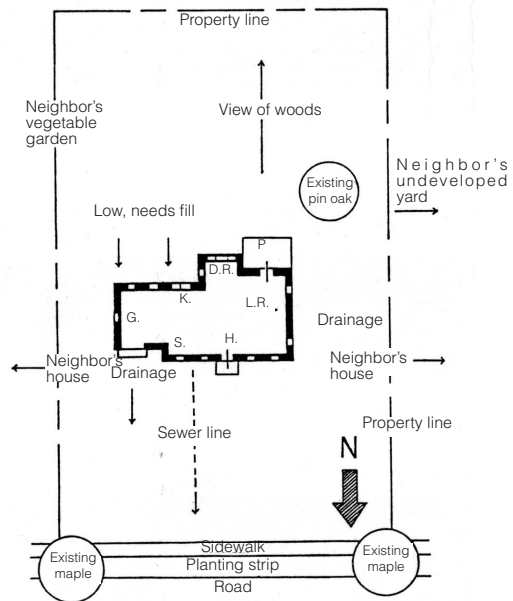

Figure 6.7. Example of a baseline map.

The map should include the following:

- Property lines.
- Undesirable features of home grounds or adjoining property.
- North point.
- Views – point arrows in direction of each good view.
- House, garage, other buildings.
- Doors, windows, porches and location of rooms.
- Existing trees, rock outcroppings.
- Walks and driveways, if already constructed.
- Contour of the land (use an arrow to show direction of surface water flow).
- Scale used.
- Location of septic tank or sewer lines.

Step 2 – Decide how to use the ground area. Items listed below are most often included in the final development. Make a list that suits your individual needs.

- Front lawn area or public area
- Vegetable garden
- Cooking and eating area
- Garden pools
- Walks
- Flower beds
- Outdoor living or private area
- Children’s play area
- Small fruit

- Driveway
- Guest parking
- Turnabouts
- Garage
- Other items particular to your land area

Step 3 – Place use areas on the map. Place the use areas on the map by creating “bubbles” that represent each use area. (Figure 6.8). Fit them together with two considerations, traffic flow and use. How will people move from one area to another or from the house to an outside area? Will it make use of existing features such as views or changes in the terrain? Try different combinations in relation to rooms of the house, surrounding areas and potential views.

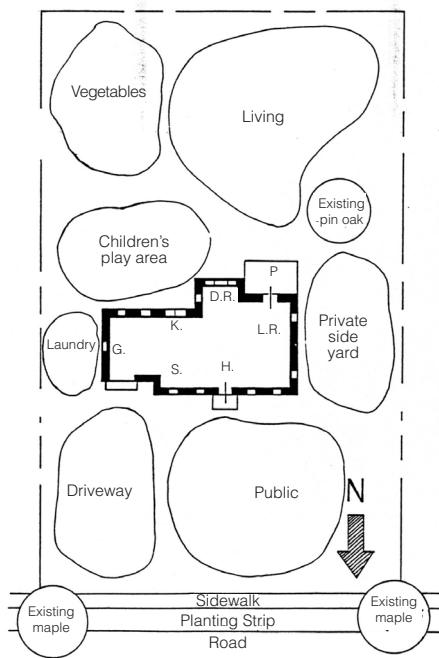

Figure 6.8. Placement of use areas on the map.

Step 4 – Develop the landscape plan. Design driveways, parking areas and walks.

Indicate where plant masses are needed for separating areas; screening undesirable views; and providing shade, windbreaks and beauty.

At this point, do not attempt to name the trees and shrubs. Think in terms of plant masses that will serve a purpose and help tie the various areas together into a unified plan considering design elements previously discussed.

In preparing the plan, use landscape symbols to indicate trees and shrub masses (Figure 6.9). Draw symbols to scale to represent the actual amount of space involved. For example, a limber pine tree at maturity will have a spread of approximately 20 feet. Make the scale diameter of the symbol; in this case, 20 feet. Indicate on the map where paving, plants and structures will be (Figure 6.10).

In developing the plan, make sure the proposed scheme is practical and that the following questions are addressed:

- Is the driveway design pleasing, useful and safe?
- Have the following been provided for: Safe entrance? Turnabout? Guest parking?
- Will guests use the front door?
- Are service areas convenient and screened from public view?

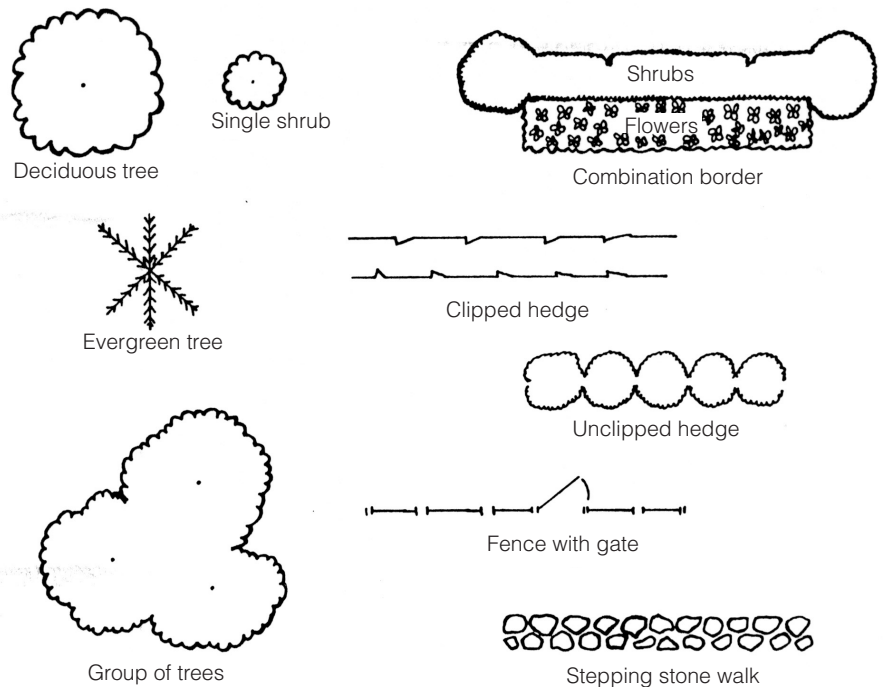

Figure 6.9. Landscape symbols.

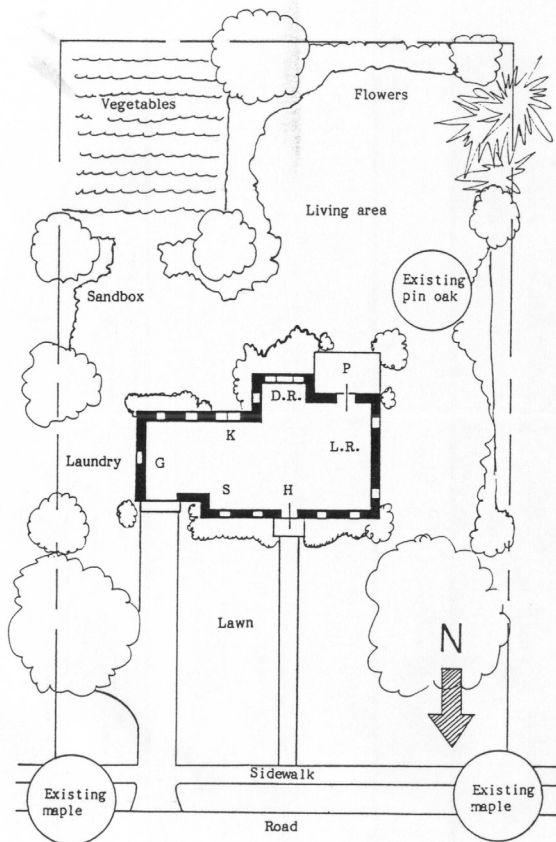

Figure 6.10. Map showing where paving, plants and structures will be.

- Will the proposed drive be too steep?
- Are the walks convenient?
- Will the view be attractive from indoor living areas?
- Has an outdoor living area been provided and is it screened from neighbors? The service area? The building?
- Do all the parts fit together into a unified plan?
- Have a good setting, background and privacy been provided?
- Are the house and major plants set back in case the highway department/local government widens the street?
- Will the proposed location of the septic tank and drainage fields interfere with planting needed shade trees?

Step 5 – General and specific planting plan. First, for each tree or shrub mass on the plan, make a set of specifications. These specifications should include:

- Height – low, medium, tall
- Form – spreading, upright, arching, globe

- Purpose – shade, background, hedge, screen, accent, mass
- Seasonal Interest – fruit, flowers, foliage
- Type – evergreen, broadleaf evergreen, deciduous
- Maintenance – subject to insects or plant diseases
- Cultural Needs – shade, sunlight, moisture requirements

Then select a plant or group of plants to meet the specifications. Consult OCES web sites, garden books, nursery catalogs or visit a local nursery. Become familiar with plant material and discuss plants with nursery staff.

Designate specific plantings on the map developed in Step 4 (Figure 6.11).

Selection of Plant Materials

Well-chosen plantings are necessary to achieve the desired landscape effect. There are hundreds of varieties of trees, shrubs, vines and perennials from which to choose. Remember, plants are not merely ornamental accessories. They make up masses and define space in the yard, and consequently, the silhouettes that produce the garden design. Therefore, when selecting plants, consider both their cultural needs and aesthetic value.

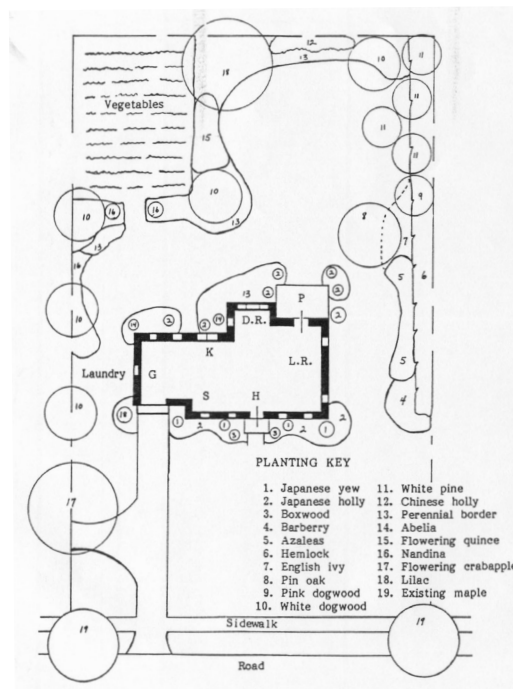

Figure 6.11. Designation of specific plantings.

Cultural considerations in selecting plants

Hardiness: This is the plant's ability to withstand winter and summer climatic changes as well as its longevity or permanence. Usually a fast-growing plant has a short life span and will consequently need replacing after a few years.

Soil and moisture conditions: These are important parts of the plant's environment. Some plants respond unfavorably when a change occurs. For example, some plants can tolerate extreme dry or wet conditions, while others cannot.

Degree of sun or shade: This depends on where the plant is to be located in the garden. Some plants just cannot take the sun, while others require full sun for best display.

Maintenance: When selecting plant materials, consider the more practical aspect of maintenance. Try to choose trees and shrubs that tend to be disease and insect resistant.

Aesthetic value: This includes texture, color or foliage, flower, fruit and bark. Select colors related to the house exterior, especially if the plant is used close to the house. Strongly contrasting textures can create interesting effects.

Aesthetic considerations in selecting plants

Plant Size: The mature size of a plant must be considered when selections are made for the landscape plan. A common mistake is the selection of plants that soon become too large for their location. The drastic pruning, which then becomes necessary, adds to the cost of maintenance and may reduce the grade and beauty of the plant. Overgrown plants left unpruned will alter the balance and accent of the design, and may partially hide the house they are supposed to complement.

The landscape picture is constantly changing because the plants that give it form and substance are continually growing. This presents a challenge to the landscape architect not found in most other artistic media. Great care must be exercised in selecting plants that will immediately create the desired composition and retain an appropriate size for many years.

Plant Form: Trees and shrubs used in landscaping develop many distinct forms (Figure 6.12). The more common forms are prostrate or spreading, round or oval, vase, pyramidal and columnar.

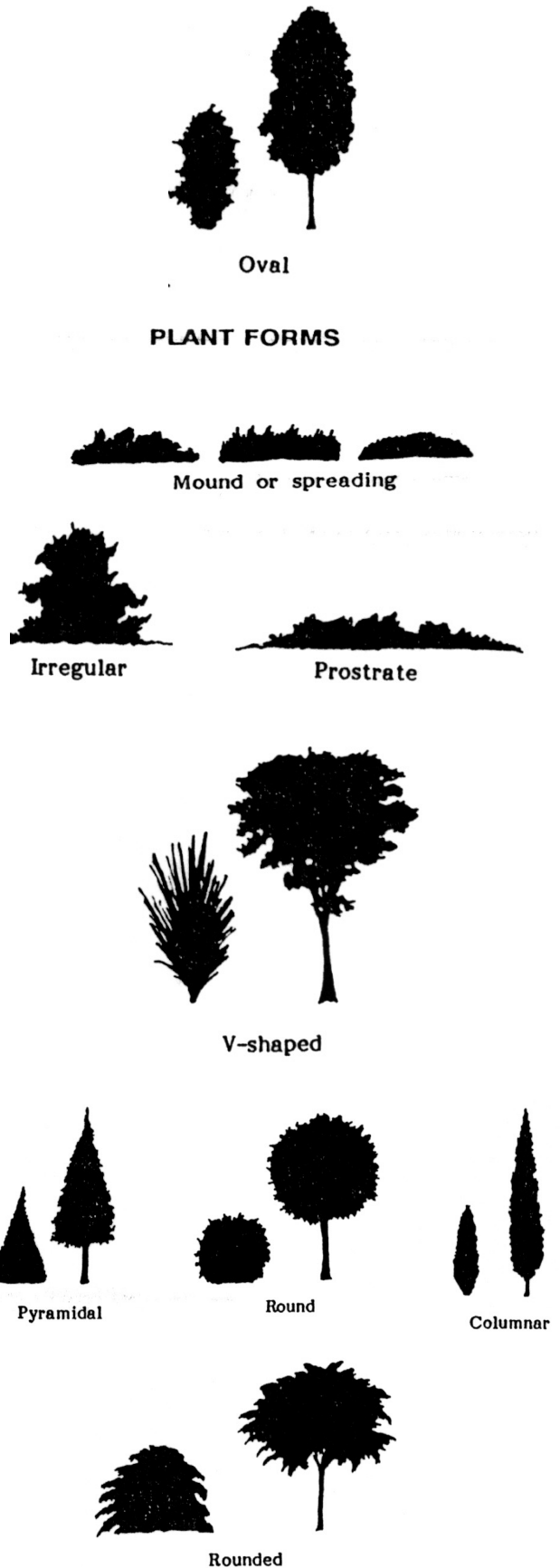

Figure 6.12. Plant forms.

The form of mature shrubs and trees is usually more open and spreading than young plants. For example, the head of a young oak tree may be pyramidal in shape; during middle age the head is an irregular oval; and during old age a large, massive oak may have a spreading vase form.

Ground covers such as turf, low-spreading shrubs, creeping plants and prostrate vines are essential materials in landscaping. The principal use of turf is for the lawn area. Other ground covers are commonly used on banks too rough or steep to mow or under trees where grass will not grow satisfactorily.

Shrubs are woody plants that grow to a height of 12 to 15 feet. They may have one or several stems with foliage extending nearly to the ground. The following are examples of the more common forms of shrubs:

- Low spreading: Juniper species
- Round or Upright: a large majority of shrubs fall into this general form
- Vase: Vanhoutte Spirea
- Pyramidal: Arborvitae species
- Columnar: Juniper species

Trees are woody plants that typically grow more than 15 feet tall and commonly have only one main stem or trunk. The head or leafy portion of the tree develops a typical form such as the following examples:

- Round or Oval: most common trees such as Maple, Oak and Pine
- Vase: Elm
- Pendulous or Weeping: Willow, Cherry and Jasmine
- Pyramidal: Cypress, Fir and Hemlock
- Columnar: Lombardy Poplar

Trees are long lived and relatively inexpensive in initial cost and maintenance compared to lawns, flower beds and many other features of the design. In the past, many builders have committed costly errors by destroying trees in establishing new residential subdivisions. Most real estate developers now appreciate the value of trees and attempt to save them when land is graded prior to the construction of houses. Regardless of our affection for trees, we must recognize they do not live forever. Old and improperly located trees should be removed and new, more suitable specimens should be planted.

Plant Texture: The texture of plant materials is dependent on the size and disposition of the foliage. Plants with large leaves, which are widely spaced, have coarse texture. A plant with small, closely spaced leaves has fine texture. Extremes in texture prevent harmony in the composition and should be avoided. On the other hand, some variation in texture is needed to give variety. Texture can be influenced on a seasonal basis, depending on whether the plant is deciduous or evergreen.

Plant Color: Green is the basic color of most plant materials in the landscape picture. A desirable variety may be secured by using plants with lighter or darker foliage tones. Accent may be introduced by the selection of flowering shrubs or those that produce colorful, persistent fruit. Care should be exercised in the use of particularly showy plants such as hydrangeas and blue atlas cedars. Such plants may so dominate the landscape as to destroy the balance and unity of the composition.

Gardening Practices for Sustainable Landscapes

Learning Objectives:

- Understand the importance of sustainable landscaping.
- Understand how to apply water, soil and energy conservation practices in landscaping.
- Understand how to reduce pesticide and fertilizer use in landscaping.

Sustainable Landscaping

Introduction

There is a growing cultural consciousness of environmental responsibility, which recognizes that humans impact the environment with everything we do. Those impacts can either work with the environment or against it. Unfortunately, it often is the latter. But we can approach our gardening and landscaping in a way that works with nature to protect the environment.

Sustainable landscaping is a comprehensive approach to gardening and landscaping. It aims to create beautiful and productive outdoor spaces in a way that benefits the surrounding environment by conserving water, improving soil, encouraging native species and reducing pesticide and fertil-

izer use. In this way, our lawns and gardens help surrounding natural environments to become more sustainable and able to continue providing environmental goods and services in the future.

Sustainable landscaping also provides benefits to the gardener/homeowner in the form of reduced water and energy costs, improved soil productivity and a more beautiful and easy-to-care-for outdoor space.

Planning and Design

Xeriscaping

When thinking about how to create an environmentally friendly and sustainable landscape, consider Xeriscaping. Xeriscaping is a landscape design strategy that emphasizes water conservation. It achieves this through the selection of native plants and/or climate appropriate plants, by properly grading and mulching soil and through the strategic use of turf areas.

Selecting native plants and/or climate-appropriate plants ensures they will be pre-disposed to the natural climate and rain cycles in the area and not require intensive care or irrigation to survive and thrive.

Proper grading and mulching ensures the landscape area can take full advantage of rain events. Grading should be such that water is not encouraged to flow off site too quickly, but is instead given time to infiltrate the soil. Concurrently, proper mulching will also help prevent evaporation of water from the top soil layers and keep it available for absorption through root systems.

Turf areas are still desirable in most landscape designs, and can contribute to the usability and

overall aesthetics of an area. But large, open golf-course quality turf areas require a great deal of water and fertilizer to stay soft and green. By being more strategic with the size and placement of turf areas and species selection, the need for water and fertilizer can be greatly reduced. For example, placing a turf area where it will receive shade from a tree for part of the day will help to reduce the irrigation need of that turf area. Choosing a turf species suitable to the climate and rainfall of a region also is important. For Oklahoma, buffalo grass is a native prairie grass well suited for our climate. Bermuda grass and other warm-season grasses are also suitable.

Permaculture

Permaculture is another design method to consider when planning an outdoor space. Permaculture can have a lot of different meanings when talking about sustainability. For the purpose of landscaping, permaculture is exploiting and imitating natural relationships to create more productive systems. It recognizes critical interrelationships and examines how those relationships contribute to the stability of the whole system.

In landscaping, it is useful to look at permaculture in terms of the layering of relationships. One way to apply permaculture layering in landscaping is to think of your plant selection in terms of canopy layers in a forest (Figure 6.14). Upper layers provide shade and mulch that help retain soil health and moisture, while lower level plants help to break down the mulch and provide ground cover to crowd out weeds. Trees will constitute the highest layer and will provide shade to the lower

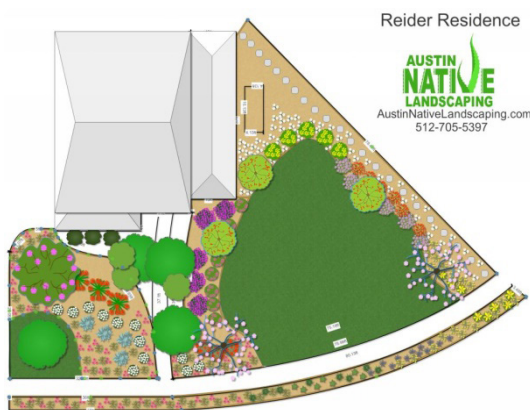

Figure 6.13.
Source: <http://lid.okstate.edu/source-reduction>

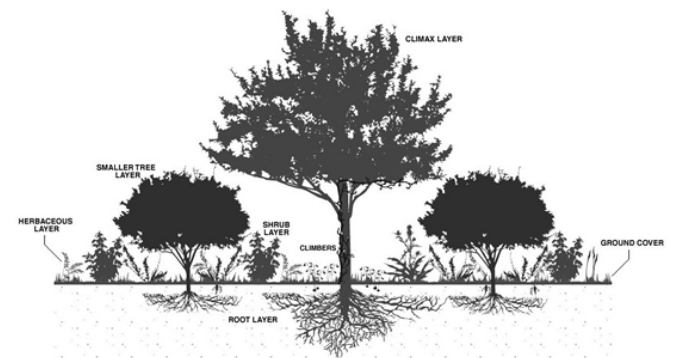

Figure 6.14. Layering relationships within a landscape.

Source: <http://www.permaculture.org/nm/index.php/site/classroom/>

levels. Below that will be smaller trees and shrubs, then ground-level plants and ground covers. If done properly, this type of layering provides beauty from ground to sky and creates a micro-canopy system that holds in moisture and does not need to be weeded.

Another important term in permaculture is guilds. A guild refers to a group of participants in a system that all work together and provide benefits to other members of the guild for an overall increase in productivity of the system. For example, consider the roll of pollinating insects like bees in a landscaping system. The bees benefit from the system by having a local source of pollen and structures on which to build hives. The bees in turn help to pollinate the plants in the system, making the plants more productive. In this way, think about each new piece of your landscape design as a member of the guild. Think about what it will be contributing to the group and what it will be withdrawing.

Water Conservation

Zone appropriate plant selection

All plants are predisposed to growing in certain climatic conditions. The USDA has mapped out areas of similar climatic conditions into different plant hardiness zones. In traditional landscap-

ing, a plant is chosen primarily for its looks, while consideration of its hardiness zone/heat zone often is a secondary concern. This may result in a beautiful landscape full of exotic plants requiring more care, maintenance and water to stay happy and healthy.

That is why it is important to choose zone-appropriate plants for a sustainable landscape. Zone-appropriate plants will be well suited to the typical temperature ranges and rainfall amounts for that zone, and will therefore require very little maintenance and supplemental irrigation.

There are two types of zones to consider: hardiness zones and heat zones (Figure 6.15). Hardiness zones focus on the lower range of temperatures for an area. Hardiness zones help to determine what plants can survive the typical winter for an area. Heat zones focus on the upper range of temperatures. A heat zone is determined based on the number of days an area experiences highs of 86 F or more. Heat zones help determine what plants can survive the typical summer in an area. Most plant labels will have a hardiness zone rating. Heat zone ratings are not as common, but are being used more often.

Oklahoma supports hardiness zones 6a, 6b, 7a, 7b and 8a, depending on the part of the state. It supports heat zones 7, 8 and 9. Most of the state is in heat zone 8. When selecting plants for your landscape, make sure the plants will thrive in those zones. Here are a few examples of popular plants that are zone-appropriate for Oklahoma: nandina, crapemyrtle, Winter Green boxwood, Burford holly and Purple Heart.

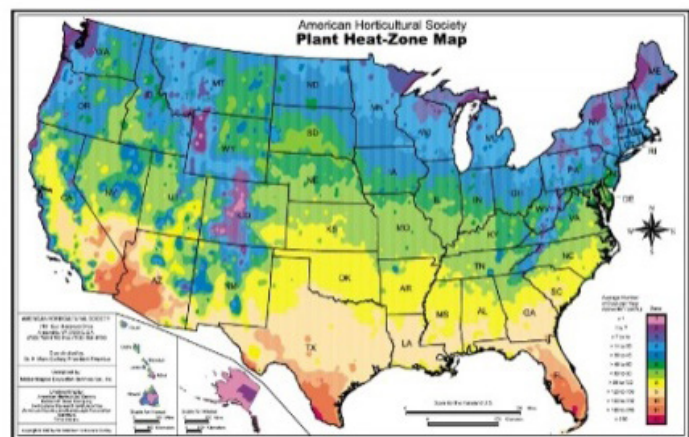
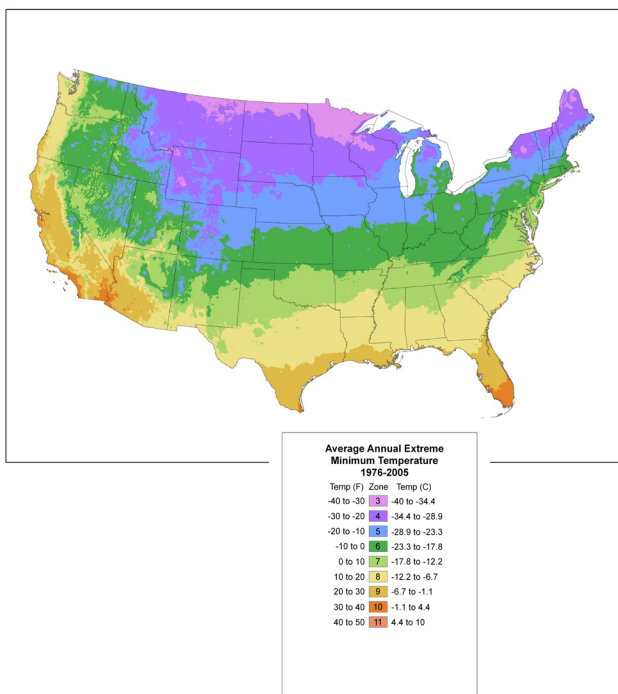

Figure 6.15. USDA plant hardiness map and the American Horticultural Society plant heat-zone map.



Figure 6.16. Drip irrigation and spray irrigation systems.

Smart irrigation

How and when to irrigate can have a huge impact on how much water is used and how much actually gets to the plants' roots. That is why it is important to employ efficient irrigation methods and use an irrigation schedule.

Drip irrigation is the most efficient method for irrigating (Figure 6.16). Spray/sprinkler irrigation is not efficient because much of the water is lost to evaporation before it ever reaches the plants. It can evaporate off leaves and branches before dripping down to the base of the plant. Spray/sprinkler irrigation also encourages mold and mildew growth on plants. Drip irrigation is much more efficient because water goes straight to the base of the plant. Very little water is lost to evaporation and the tops of the plants stay dry. This helps protect some plants against diseases such as rust blight.

Zone irrigation is another smart way to irrigate to conserve water use. In zone irrigation, plants are grouped according to their irrigation needs, then irrigated as a group according to that need. Plants needing a lot of water would be grouped together and watered often, while plants not needing as much water would be grouped together and watered less often. When plants with different water requirements are intermixed, the whole area would have to be over-watered to accommodate all the plants.

When to irrigate is just as important as *how* to irrigate. For starters, irrigate in the morning between 4:00 a.m. and 9:00 a.m., when the air is still cool and wind is typically calmer. It is also better to water deeply less often, than to water shallowly more often. Less frequent deep watering encourages deeper root growth.

Following an irrigation schedule that can flex with weather changes is another smart way to irrigate effectively. For example, watering every third day is planned, but if the weather is particularly hot and windy, moving to an every-other-day schedule

is needed. Concurrently, if it rains for two days in a row, consider the third day as the first day of the schedule and do not water again until the third day without rain.

Sources: <http://www.wikihow.com/Water-Your-Lawn-Efficiently>; <http://www.irrigationtutorials.com/irrsch.htm>

Runoff management and re-use

Runoff is a very important environmental concern for two reasons. First, reducing runoff and keeping more water on-site to be absorbed will reduce the need for future irrigation because the soil will stay saturated for longer. Another reason is when water runs off of landscapes and pavement areas, it picks up fertilizers, pesticides, herbicides, automotive products, etc. and transports them into either city water treatment facilities or local water bodies. In either case, these non-point source pollutants (meaning the pollution did not come from one specific source) can negatively impact the organisms that depend on those water sources, including us!

There are a couple of strategies that can be employed in the landscape to help retain water on-site for longer and reduce the amount of runoff from irrigation or rain events. One such strategy is the use of rain gardens in your landscape (Figure 6.17). A rain garden is a small depression behind a berm in the landscape designed to catch runoff and allow it to drain into the soil during a 24-hour period. This allows any pollutants in the runoff to be absorbed into the rain garden soil, instead of running off into a local pond or stream. Since they drain in about a day, and since a mosquito's larval cycle is two to three days, rain gardens can actu-

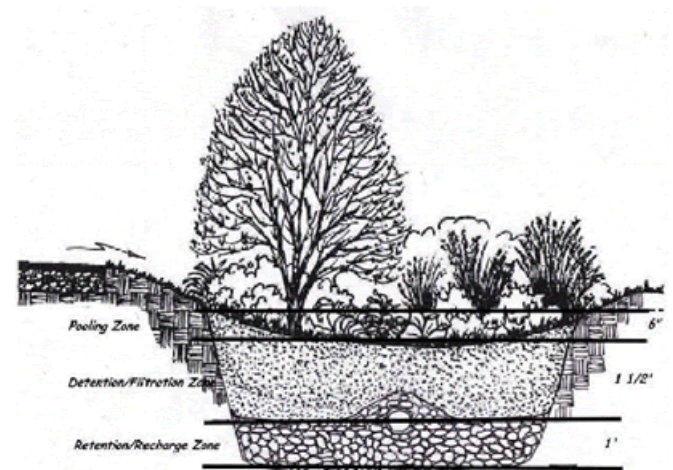

Figure 6.17. Diagram of a rain garden.

ally help control mosquito populations. For more information about constructing rain gardens, contact the local Extension office.

Runoff is maximized on impermeable surfaces, such as roads and parking lots. But a new technology is available to mitigate this problem. Pervious pavement is a newer construction innovation creating a strong surface, but has plenty of voids for water to pass through. This allows rainwater/irrigation to soak through the pavement and into the soil rather than running off site. By capturing stormwater and allowing it to seep into the ground during natural rainfall cycles, pervious pavement is instrumental in recharging groundwater, reducing stormwater runoff and meeting U.S. Environmental Protection Agency (EPA) stormwater regulations (CFR 40 130.3).

Pervious pavement can be used one of two ways. The first is in the form of concrete and asphalts that are made with very low amounts of fine materials. When made this way, the larger aggregates are held together, but still have plenty of voids between them that allow water to pass through. The second is in the form of structural pavers. This is a more system-oriented method that uses individual pieces, such as open-celled grids or interlocking blocks to create a surface, as opposed to a poured contiguous material. These paving systems will have porous elements mixed with traditional construction media such as concrete blocks filled with gravel.

Appropriate applications for pervious pavement include commercial parking lots, driveways, sidewalks and roads with low volume traffic. Pervious pavement systems are not suitable for use in areas with polluted runoff such as gas stations.

The materials and installation of pervious pavement systems are more expensive compared to conventional paving methods. However, their costs can often be offset by the costs of stormwater management systems that have to accompany conventional pavement such as curbs, piping, retention ponds, etc.

Another way to prevent runoff is to capture rainwater for your own use (Figure 6.18). An average residential roof will produce a large amount of runoff with very little rainfall. Rainwater harvesting systems can be as simple as a rain barrel under a gutter with a spigot at the bottom to be used to water a flowerbed, or they can be designed for much larger holding capacities and filtered to be used for drinking water and toilet flushing.

Because roofs will collect dust and bird droppings between rainfall events, it is best to include a first-flush diverter and/or debris screens in the rain harvesting system. The run-off that first comes off a roof is called the “first-flush” and will have the highest percentage of contaminants. Debris screens fixed into the gutter/piping will help pull out large debris like leaves and twigs. A first-flush diverter helps isolate the first flush from the rest of the runoff, so harvested water has a lower percentage of

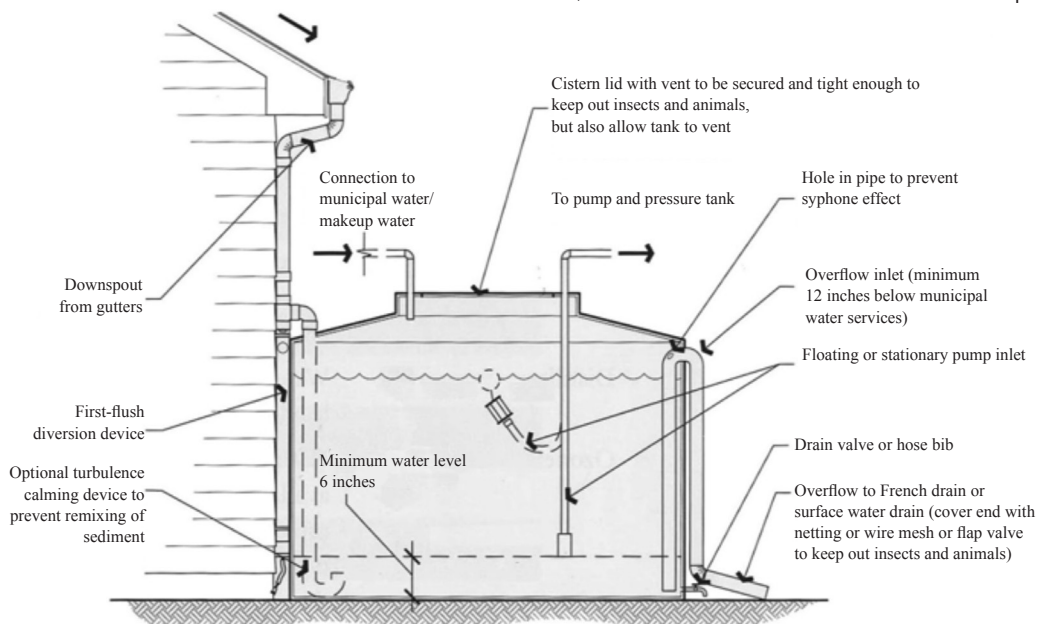

Figure 6.18. Rainwater catchment systems.

roof contaminates. The basic design of a first-flush diverter is to route the water coming off of a roof into a slow-draining pipe that will fill up first. Once it is full, an over-flow valve will carry subsequent run-off into the primary storage container. It is also important to include an over-flow valve in the storage container. Once the container is full, any excess runoff will be directed away from buildings and foundations.

For more information on installing rainwater harvesting systems, including information on designing larger cistern systems, and for information on calculating runoff amounts based on catchment area, see the Oklahoma Cooperative Extension fact sheet on rainwater harvesting. <http://osufacts.okstate.edu/docushare/dsweb/Get/Document-8238/BAE-1757web.pdf>

Sources:

http://www.ok.gov/conservation/News/OCC_Rain_Gardens_featured.html

<http://lid.okstate.edu/bioretention-cells-and-rain-gardens>

<http://lid.okstate.edu/pervious-pavement>

http://www.sustainablecitiesinstitute.org/view/page.basic/class/feature.class/Overview_Lesson_Pervious_Paving;jsessionid=484ACFA250EFFC68C5102B8126937EC8

Soil Conservation

In addition to using water in a smart and sustainable way, it is important to give the same consideration to the soil. Not all soils are created equal and can become a depleted resource just like other natural resources. That is why it is important to incorporate sustainable practices for soil improvement — to ensure its health is maintained year after year, without the constant application of synthetic fertilizers.

Soil improvement

Before planting anything, get a soil test for an accurate picture of the soil's health. This will allow any necessary steps to be taken to improve the soil's health before adding plants. Contact the local county Extension office for details on how to submit a soil sample for testing.

There are three main ways to improve soils to support healthy and productive landscapes: Soil pH, available organic matter and drainage.

Soil pH refers to the relative acidity or alkalinity of the soil. Plants need soil that is not too acidic or too alkaline. Unfortunately, different plants will have different pH requirements. Make sure to consider

pH requirements when grouping plants. Adjustment of the pH of the soil can be made in a particular area so it is best suited for the pH needs of that plant grouping. Generally speaking, most plants prefer slightly acidic soil – with a pH of 6.0 to 7.0.

If a soil test reveals the soil is too acidic or too alkaline, there are soil amendments that can be added to change the pH. The pH scale ranges from 0 to 14. A pH of 7 is neutral, which is neither acid nor alkaline. Below 7 is acid and above 7 is alkaline. If the soil is too alkaline, adding sulfur will lower the pH and make the soil more acidic. If the soil is too acidic, adding lime (limestone) will raise the pH and make the soil more alkaline.

Another important part of soil health is having an adequate amount of available organic matter in the soil. Organic matter typically refers to composted plant and animal wastes such as coffee grounds, horse manure or grass clippings. Soil microbes will break down organic matter into ammonium, phosphates and nitrates that are then changed to inorganic nitrogen (N) and phosphorous (P), which can be absorbed by plants. This type of nutrient source is best for sustainable landscaping because it is a slow and natural release of N and P compared with commercial fertilizers which may release a lot of both all at once and not necessarily in the best ratios for the plants. Nitrogen, phosphorous and potassium are the primary nutrients needed for healthy plant growth and development. Except for very sandy soils, most soils in Oklahoma have sufficient quantities of phosphorous and potassium. Nitrogen is the main nutrient of concern and needs to be replenished periodically in landscapes. If not, the soil will become depleted and the plants will essentially starve. Increasing the available organic matter in the soil is the best way to improve the nitrogen content.

Organic matter also encourages water infiltration and productivity of the soil ecosystem. As the organic matter is broken down by bacteria, the space it occupied is left vacant. These voids allow water to infiltrate deep into the soil and increase its total water-holding capacity (also called field capacity). The voids also provide space for aerobic organisms to thrive. The bacteria that break down the organic matter, and the waste they leave behind, also provide nutrients for a large variety of beneficial flora and fauna that contribute to the health of the soil ecosystem, such as earth worms, microbes, insects and fungi.

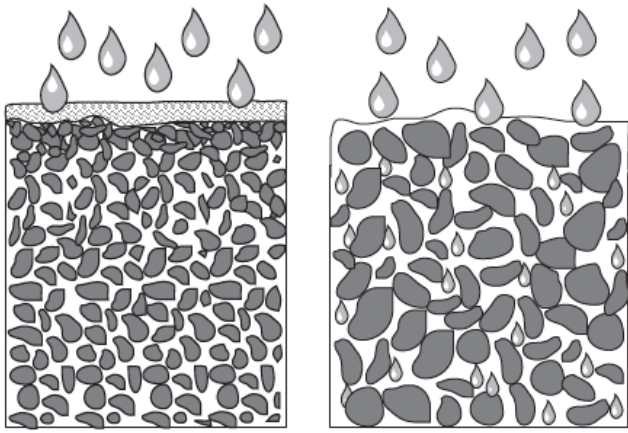

Figure 6.19. Pore spaces of clay soil (left) versus sandy soil (right).

Improving soil drainage is another way to promote sustainable soil conservation. Soils with high clay content are prone to drainage issues. This is because the pore space between soil particles is very small compared to sandier soils (Figure 6.19). Small pore spaces allow for a very small amount of water to infiltrate down through the soil, causing soils to become saturated for too long. This can be very damaging to plants and aerobic microorganism populations. Roots must have oxygen to survive and root activity shuts down in waterlogged soils. Plants growing in wet soils are typically shallow rooted. Many plants are prone to root rot in wet soils. Prolonged periods of waterlogged soil conditions lead to the decline or even death of most plants.

A simple test to evaluate soil drainage is to dig a hole 12 inches deep and fill it with water. If the water fails to drain in 30 minutes, the soil has a drainage problem. If the hole fails to drain in 24 hours, waterlogged soils may affect plant growth.

On a fine-textured, clayey soil, the repeated application of organic matter over time helps to glue the tiny clay particles into larger chunks or *aggregates* creating larger pore spaces.

Sources:

<http://practicalfarmers.org/images/pdfs/Joel%20Gruver%20WIU:%20Basic%20Soil%20Improvement%20Techniques%20for%20Sustainable%20Farmers.pdf>

<http://www.ext.colostate.edu/mg/gardennotes/219.html>

<http://www.pubs.ext.vt.edu/426/426-046/426-046-PDF.pdf>

http://mawaterquality.org/publications/pubs/composting_resource_directory.pdf

Use of mulch

The use of mulch is described in greater detail in Chapter 4. However, because it plays a prom-

inent role in landscape design, it is worth mentioning here as well. Mulch can be just about any material that is placed on the ground around a plant's base. The best mulches are made of organic material such as woodchips, leaves and grass clippings that will break down into compost. Mulch provides a landscape with three direct benefits: 1) water conservation, 2) protection from soil compaction and 3) weed reduction. Mulch also can be a feature of the landscape aesthetic as well. Some mulch comes in different colors like red, green, brown, or black and can be chosen to complement the color scheme of the landscape and provide color contrast with turf areas.

Energy Conservation

Landscape choices can significantly impact the energy use of a commercial or residential property. In conventional construction, a great deal of energy is lost through the walls and roof via thermal exchange. Green roofs and strategic shade can help reduce the energy lost through thermal exchange.

Green roofs

A green roof is a low-maintenance, vegetated roof system constructed for the benefits of reducing rainwater runoff, conserving energy lost through thermal exchange and providing more biodiversity to an area. Green roofs transform rooftops into a form of infrastructure with environmental, economic, aesthetic and social benefits.

These unique structures reduce storm water runoff significantly by retaining large amounts of water in the soil to be absorbed by the vegetation later. Studies have shown that a 4-inch deep green roof can retain up to 50 percent of total rainfall.

The reason green roofs are able to provide such significant energy savings is because the air trapped in the drainage layer acts as an insulator between the building's inside and outside temperatures. A green roof can reduce the heat lost through the roof in the winter by 25 percent. And in the summer, the sun's heat is used for evaporation and plant growth rather than being absorbed into the structure like a conventional roof. A green roof will also reduce local levels of carbon dioxide and increase the local levels of oxygen and humidity.

Green roofs are similar to conventional roofs in their basic construction (Figure 6.20). Both start with a waterproof membrane over roof sheathing.

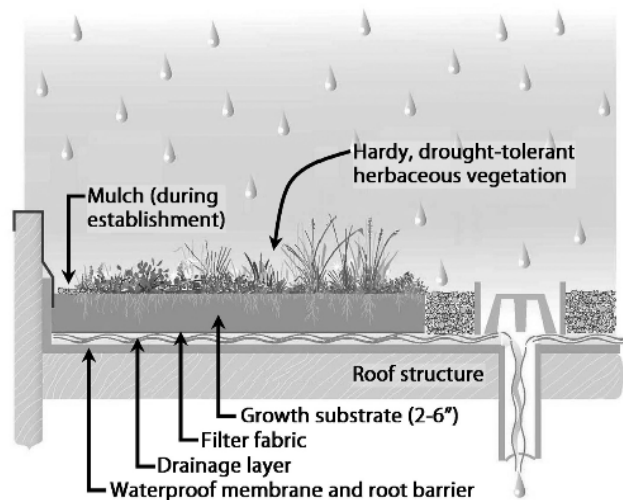

Figure 6. 20. Construction of a green roof.

But that is where the similarities end. Green roofs will also include a root barrier, a drainage layer, filter fabric, and 2 to 6 inches of lightweight growth substrate with very little organic content. Too much organic content results in settling or too-rapid plant growth. Regionally appropriate plants are then planted in the growth substrate. Sedum and other succulents have been popular choices for green roofs in Oklahoma.

It is important to note that green roofs require moderate structural support, but this can be easily accommodated during design for new construction. Existing roofs may require additional structural supports that can be added during re-roofing or renovation. A green roof may weigh approximately 10 to 25 pounds per square foot when fully saturated, whereas a conventional rock ballast roof weighs approximately 10 to 12 pounds per square foot. The added upfront costs of a green roof are typically offset through time, as green roofs will last much longer than conventional roofs. This is because the structural portion of the roof is protected from the intense heat and UV rays from the sun.

Source: <http://lid.okstate.edu/green-roofs>

Strategic shade and windbreaks

Do not underestimate the impact that shade provided by trees and shrubs can have on the energy savings during hot Oklahoma summers. Planting the right trees in the right places can reduce summer air conditioning costs by 35 percent and winter heating costs by 10 to 30 percent. For the biggest impact, plant large deciduous trees on

the east, west and northwest sides of your home or business. Prune lower branches to prevent blocking views from windows. Kentucky Coffee trees are well suited to this purpose. Oaks will also provide ample shade, but are slower growing. Pecan trees will also grow well in Oklahoma. Do not forget to shade air-conditioning units to help keep them cooler and running more efficiently.

Using trees and shrubs as windbreaks will reduce the loss of heat in the winter that results from convection. Up to one-third of heat loss from a building can be lost through roofs and walls as a result of the wind increasing convection.

Source: <http://pods.dasnr.okstate.edu/docushare/dsweb/Get/Document-2215/HLA-6417web.pdf>

Reducing Pesticides and Fertilizers

Reducing pesticide use

For landscapes to be healthy and productive, they need to be integrated into the local ecosystem rather than fighting against it. For this reason, pesticide use in a landscape should be used as sparingly as possible. Most pesticides will affect many more organisms than the target pest(s), and many of these organisms are beneficial to the landscape plants and soil. Furthermore, pesticides applied directly to plants and soils can make their way into groundwater or get picked up in rainwater runoff, ending up in streams and lakes, affecting many other non-target organisms.

The best way to protect against pests is to start with healthy plants. Healthy plants are less attractive to pests, and are better able to defend and recover when attacked by pests. Choosing native varieties with a proven record of doing well in Oklahoma will be predisposed to resist/endure native pests. Maintaining soil health is another way to mitigate the need for pesticides in the landscape. Healthy soils produce healthy plants. Healthy soils also promote a balanced ecosystem that can support a variety of animals, including those that prey on garden pests.

Plant associations or intercropping is an easy, natural way to reduce pesticide use in your landscape. Plant associations recognize that there is a great deal of cooperation in nature and it can be modeled between plant and animal species in our own landscapes for the benefit of the whole area.

This involves selecting and grouping plants according to the natural effects they have on pests and soils in the landscape. This may also involve placing plants repelling pests or having an adverse effect on pests' survival around/near more susceptible plant species. For example, squash beetles are repelled by the smell of radishes, so planting radishes around squash plants can make the squash plants less attractive to these aggressive pests.

More generally, intercropping can reduce the need for pesticides simply by elevating the level of diversity among plant species. Intercropping is typically used in larger agricultural settings, but the same principles for pest reduction apply. There are two suggested reasons why high diversity leads to reduced susceptibility to pests: 1) a more diverse environment would support a larger number and variety of natural predator populations, and 2) when pests feeding on one type of plant are allowed to exist in a monoculture of that plant, they have a greater concentration of resources in which to move, feed, breed, etc. This would lead to overall greater numbers of that pest.

Deliberately attracting and/or releasing beneficial insects into the landscape is another way to reduce pesticide use. For example, if aphids are a problem, ladybugs (aphid's natural predators) can be ordered and released in large quantities. If cabbage loopers are decimating the brassicas, parasitic wasp eggs can be purchased and hatched to reduce the looper population. Lacewing larva are voracious predators and also can be purchased. They eat aphids, thrips, scales, moth eggs, small caterpillars and mites. It is also important to remember spiders are very beneficial for controlling garden pests. Take comfort in knowing that most spiders found in gardens do not move indoors and are not typically venomous varieties. Providing straw mulches will encourage an increase in spider populations.

Sources:

<http://entoplp.okstate.edu/ipm/talks.html> http://www.clemson.edu/sustainableag/IP135_intercropping.pdf
<http://www.epa.gov/pesticides/lawncare/>
<http://www.organicgardening.com/learn-and-grow/meet-beneficial-insects?page=0.3>
<http://pods.dasnr.okstate.edu/docushare/dsweb/Get/Document-2341/EPP-7461web.pdf>

Reducing fertilizer use through composting

The most direct way to reduce synthetic fertilizer use in a landscape is to reduce the need

for it by providing regular applications of organic compost. Organic compost will provide all the necessary nutrients for proper plant health. It also provides many other benefits for plant and soil health that synthetic fertilizers do not. Some of these benefits have already been discussed.

Appropriate time and amount of fertilizing

If it is not possible or convenient to provide the landscape with regular applications of quality compost, then use synthetic fertilizers to keep it healthy. Synthetic fertilizers are developed to be a delivery system for the primary plant nutrients: nitrogen, phosphorus and potassium. These nutrients are essential for healthy plant growth.

Fertilizers can be made with varying ratios of these nutrients. It is important to understand the nutrient requirements of the plants before applying fertilizer. For example, if the soil test indicates a primary nutrient demand of nitrogen, make sure the nitrogen number (or the first number in the analysis) is the biggest number on the label. A 10-20-5 fertilizer is providing other nutrients the area doesn't need (phosphorus and potassium). This excess phosphorus likely will be washed away with rainwater run-off and end up in a local stream or lake, where it will contribute to toxic algae blooms. This demonstrates how choosing the wrong kind of fertilizer can be both a waste of money and a potential environmental hazard.

Synthetic fertilizers will provide instructions for application amounts on the packaging. These instructions should be followed. The old adage that if a little is good, a lot must be better does not apply to fertilizer. Applying more than the recommended amount of fertilizer will result in excess product being 1) wasted, 2) carried into local streams and lakes via stormwater/irrigation runoff and/or 3) may cause a nitrogen burn, whereby the exchange of nutrients actually reverses. Instead of absorbing the nutrients, a plant's roots will expel water and kill the plant.

Source: <http://www.learn2grow.com/gardeningguides/fertilizer/basics/understandingfertilizernumbers.aspx>

ORNAMENTALS PART 2

HERBACEOUS PLANTS

Landscape developments should provide attractive, useful and comfortable surroundings for their owners and environment. The selection of ornamental plants is categorized into herbaceous ornamentals (perennials and annuals) and woody ornamentals (trees, shrubs, vines/ground covers). Factors in selecting plants based on their desired use, environment and associated maintenance practices is discussed in this section.

House plants, used to make the interior of the home attractive, also have special growing requirements, which are covered under this section.

Learning Objectives:

After completing this section, Master Gardener trainees will be able to:

- Be able to discuss several aspects of color in relationship to the home landscape and the design of flower gardens.
- Be able to explain several ways of using flowers in the home landscape plan.
- Understand what the term “flowering annuals” refers to and give several examples of commonly grown annuals.
- Be able to give a general description of soil preparation for planting flowers.
- Be able to discuss starting annual flowers from seed.
- Be able to briefly discuss pest management for flowering plants.
- Understand the life cycle of biennials.
- Be able to explain what “perennial” means, and list some of the advantages of and considerations in growing perennial flowers.
- Understand some of the general criteria for selecting perennials.
- Be able to describe several aspects of cultural management of the perennial flower garden: watering, weeding, fertilizing, etc.

Herbaceous Plants

Flower gardening is the gardener’s reward for hard work. Flowers and flower borders provide color against the predominant green of a landscape. They are the accent and contrast making a landscape lively and interesting. Flowers also complement most of the features that conventional landscaping materials, such as trees and shrubs, establish. They can add depth and dimension, form and texture, and change heights and slopes, besides their most obvious asset, which is color. Flowers can also be useful, providing culinary herbs for the table and cut flowers for arrangements.

Planning the Flower Border

Much of the excitement of creating an herbaceous border lies in its great flexibility of design. In form, placement and selection of plants, the contemporary border follows few rigid rules and allows fullest expression of the gardener’s taste.

The first step in planning for an all-season, mixed perennial border is to select key plants for line, mass, color and dependability. Line is the silhouette or outline of a plant, mass is its shape or denseness, and dependability refers to its ability to remain attractive with a minimum of problems. Garden books, catalogs and the internet can be very useful for reference.

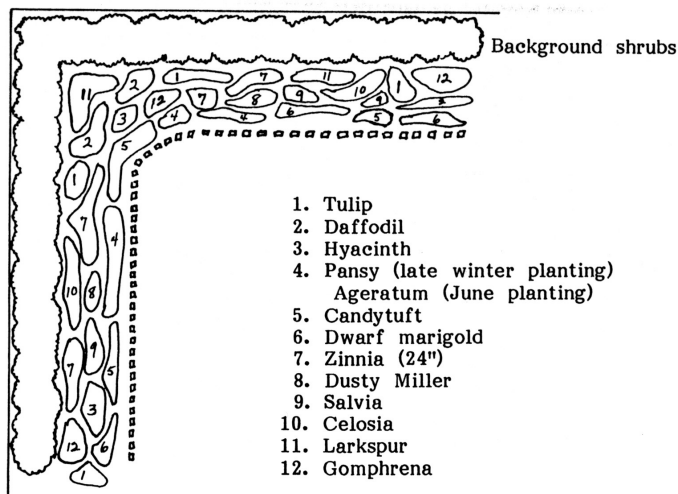

Figure 6.21. Example of a flower border.

The most attractive flower borders are those located in front of a suitable background such as a fence, shrubbery or a building. In some cases, tall flowers such as hollyhocks or sunflowers may serve a dual purpose as flowers in the border and as background plants. Annual or perennial flowers of medium height may serve as background plants for a short border planting.

A general rule is to avoid a ruler-straight front edge, unless the garden is very spacious or formal. A gentle to boldly sweeping curve, easily laid out with a garden hose, is best and the border can taper as it recedes from the main viewing point if an effect of distance is desired. The deeper the curve, the slower the eye moves and the greater will be the visual enjoyment. A border outlined with bricks or flat stones set flush with the soil is better than a steeply cut lawn edge, which must be trimmed after mowing.

Even the advanced gardener finds it advantageous to plan a border to scale on graph paper. The hardest task, organizing the selection of plants, will be simplified if only two main mass forms are considered: drifts and clumps. Drifts are elongated groupings of a plant that flow through sections of the border. Clumps consist of circular groupings of a variety or a single large plant such as a peony. The length of drifts and the diameter of clumps, as well as their heights, should be varied for best effect. The dimensions should always be in proportion to the overall size of the border.

Establish plants in groups large enough to form masses of color or texture. As a rule, five to

seven plants will create the desired effect. A large delphinium or peony will be of sufficient size to be attractive, but a random collection of different small- to medium-sized plants will present a disorganized, checkerboard appearance. Each group of flowers should have an irregular shape. These masses of color and texture should blend into a pleasing pattern of color harmony. Dwarf flowers may be used as a continuous edging or border along the front of the bed.

Flower borders may be of any width, depending on the space available. In a small yard, the bed may be only 2 or 3 feet wide. In a spacious location, the border planting may have a width of 6 or 8 feet. If the border is quite deep, a pathway of stepping stones may be helpful as a means of working among the flowers without compacting the soil.

Tall flowers should be selected for the back part of the bed, with medium-tall species in the middle and dwarf varieties along the front as edging plants. Plants along the front edge of the flower bed should be located back far enough to allow easy mowing of the lawn.

Plant height is best limited to 2/3 the width of the border (e.g., no plants taller than 4 feet in a border 6 feet wide). Height lines should be broken up by letting some tall plants extend into the medium height groups, with a few recessed clumps or drifts leading the eye back into the border. This gives a more natural effect than a step profile. Try to vary heights, but in general, keep taller plants in the back and shorter ones toward the front.

The distance between plants in a flower border depends on the form of the individual plants and the effect that is desired in the landscape. Allow adequate space between plants. A common mistake is crowding plants too much.

The enormous color range in perennials, plus ease of relocation if disharmony occurs, give the gardener great latitude in choosing and combining colors. A border in tones of the same color can be effective, several closely related colors may be used, or the border may be made wildly exuberant with a vast variety of hues in one or more seasons. Hues are modifications of color such as orangish-red. The objective is a balanced composition in every season, with no section being at any time too heavily weighted with one color, and the bloom so distributed that it always makes a pleasing pattern through the bed.

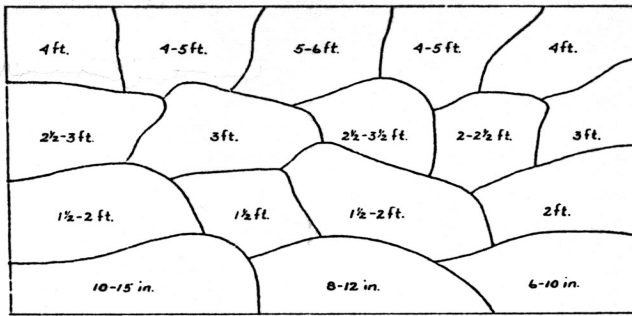

Figure 6.22. Dividing a flower border into bold plant groupings according to height. Background: large groups of tall plants. Foreground: shallower, wider groupings of small plants.

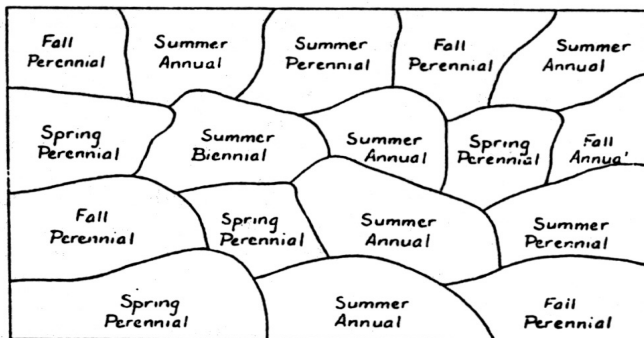

Figure 6.23. Selection of garden groups as to season of flowering and whether annual, biennial or perennial.

Many gardening books give excellent lists of compatible colors. These, plus a garden notebook and camera is invaluable for planning and revising color schemes. For real floral artistry, it is perhaps more important to consider intensity, which is the vividness of a color, rather than hue. For example, light tones placed near dark ones, or contrasting palest and intense tones can give new interest and life to the border. Also consider location and color. Near patios, white is especially good because it shows up well in the evening or dusk hours when patios are often in use. Some colors are suitable only as dramatic accents: deep, pure red clashes with almost anything (unless softened by dark green foliage), yet properly used, it confers strength and depth. White flowers and gray foliage are indispensable as separators of conflicting colors.

Red, orange and yellow are warm colors. Blue, green and violet are cool colors. The use of warm colors in the flower border of a small yard will give the illusion of little space. Conversely, the use of cool colors gives the impression of openness and space. In general, the smaller the area, the fewer warm colors should be used.

As gardeners become adept at producing constant color harmony in the border, they become more aware of the roles played by plant forms and foliage. Good foliage is obviously vital in plants with short blooming periods. Consider how much of the plant foliage will be usable and whether it is a positive or negative attribute. Some plants practically disappear when their blooming season is over (i.e., Oriental poppy and bleeding heart), but others stay presentable even when not in flower. Plants with distinctive forms, color and foliage -- airy and delicate, or strong and solid -- are wonderfully useful for creating interest. Ornamental grasses and even handsome foliage vegetables like broccoli, cardoon and asparagus can be used for effect.

The most logical way to choose plants is first by location; second, period of bloom; then height and width; and finally, color. Location takes into account the amount of sun or shade and water required. This information is easy to find in books on perennials, in catalogs and on the internet.

The only restrictions on any given plant will be environmental. A lack of ability to tolerate winter or summer temperature extremes, special soil, moisture, light needs and any limits the gardener must place on time available for maintenance.

Even in a small border, single plants of different varieties should not be used. This gives a jumbled look. Do not set in precise rows, but in groups, as they might grow in nature. Allow enough space for each group to grow comfortably. Decide which flowers you like best, and let these be the basis of your planting. Place them in several spots, if you like, down the length of the border, but don't overdo any one plant.

The longer the border has flowers in bloom, the more it will be enjoyed. Consider the months when each plant will be at its best. Do not confine yourself to material that blooms all at one time. Aim for a steady succession of color.

A last bit of advice: don't be afraid to be bold, even if it results in some mistakes. Flowers are easy to move, change or take out altogether. There

is no need to be conservative or confined. Flowers are fast growers and can be transplanted almost any time to help create the desired effect.

How many bedding plants do I need?

Avoid over- or under-buying the number of bedding plants you need. All it takes is some simple arithmetic.

Measure the area of your garden and calculate its square footage (width x length = square feet). If the area is irregularly shaped – oval, round or long and winding – a rough estimate is good enough.

Use Table 6.1 to estimate the number of plants needed. Purchase a few more than you will need in case some are damaged by weather, animals or pests.

Annuals

Annual flowers live only one growing season, during which they grow, flower and produce seed, thereby completing their life cycle. Annuals must be set out or seeded every year. Some varieties will self-sow or naturally reseed themselves. This may be undesirable in most flowers because the parents of this seed are unknown and hybrid characteristics will be lost. Plants will scatter everywhere instead of their designated spot. Examples are Alyssum, petunia and impatiens. Some perennials, plants that live from year to year, are classed with annuals because they are not winter-hardy and must be set out every year; begonias and snap-



Figure 6.24. A full sun annual border planting.

dragons are examples. Annuals have many positive features. They are versatile, sturdy and relatively cheap. Plant breeders have produced many new and improved varieties. Annuals are easy to grow, produce instant color and most importantly, bloom for most of the growing season.

There are a few disadvantages to annuals. They must be set out as plants or sowed from seed every year, which involves some effort and expense. Some plants require old flower heads to be removed on a regular basis to ensure continuous bloom. If they are not removed, the plants will produce seed, complete their life cycle and die. Many annuals begin to look disreputable by late summer and need to be cut back for regrowth or replaced.

Annuals offer the gardener a chance to experiment with color, height, texture and form. If a mistake is made, it's only for one growing season. Annuals are useful for filling in spaces until permanent plants are installed; to extend perennial beds and fill in holes where an earlier perennial has finished blooming or the next one has yet to bloom; to cover areas where spring bulbs have bloomed and died back; and to fill planters, window boxes and hanging baskets.

Culture and maintenance of annuals

Site selection. Consider aspects of the site that affect plant growth such as light, soil characteristics and topography. Different annuals perform well in full sun, light shade or heavy shade. The slope of the site will affect temperature and drainage. Soil texture, drainage, fertility and pH influence plant performance.

Site preparation. Preparation is best done in the fall. Proper preparation of soil will enhance

Table 6.1. Guide to estimating number of plants needed based on square feet of bed and spacing of plants.

<i>Recommended Spacing</i>	<i>Number of Plants per Sq. Ft.</i>
6 inches	4
8 inches	2.25
10 inches	1.44
12 inches	1
18 inches	.44
24 inches	.25

Example: A 125-square-foot garden, using plants recommended to be spaced 10 inches apart would need approximately 180 plants (125 x 1.44 = 180).

success in growing annuals. First, have the soil tested and adjust the pH if needed. Check and adjust drainage. To do this, dig a hole about 10 inches deep and fill with water. The next day, fill with water again and see how long it remains (not exceeding 8 hours). If drainage is poor, plan to plant in raised beds. The next step is to dig the bed. Add 4 to 6 inches organic matter to improve soil texture. Dig to a depth of 12 to 18 inches and leave "rough" in fall or early spring. Finally, in spring, add fertilizer, spade again and rake the surface smooth.

Seed selection. To get a good start toward raising vigorous plants, buy good seed packaged for the current year. Seed saved from previous years usually loses its vigor. It tends to germinate slowly and erratically and produce poor seedlings. Keep seed dry and cool until planted. If seed must be stored, place in an air-tight container with powdered milk to absorb excess moisture and refrigerate. When buying seed, look for new varieties listed as hybrids. Plants from hybrid seed are more uniform in size and more vigorous than plants of open-pollinated varieties. They usually produce more flowers with better substance.

Starting plants indoors. The best media for starting seeds is loose, well-drained, fine-textured, low in nutrients and free of disease-causing fungi, bacteria and unwanted seeds. Many commercial products meet these requirements. Fill clean containers about 2/3 full with potting medium; level the medium and moisten it evenly throughout. It should be damp but not soggy. Seeds should be placed to a depth of about two to three times the diameter of the seed. Very small seeds can be sprinkled on the surface and lightly covered with additional potting soil. Seed may be sown in flats by following seed package directions or directly in individual peat pots or pellets, two seeds to the pot. After seed is sown water with a fine mist. Place a sheet of plastic over seeded containers and set them in an area away from sunlight where the temperature is between 60 F and 75 F. Bottom heat is helpful. As soon as seeds have germinated, remove plastic sheeting and place seedlings in the light. If natural light is poor, fluorescent tubes can be used. Place seedlings close to the tubes. After the plastic is removed from the container, the new plants need watering and fertilizing, since most planting material contains little or no plant food. Use a mild fertilizer solution after plants have been watered. When seedlings develop two true leaves,

thin plants in individual pots to one seedling per pot; transplant those in flats to larger flats, spacing 1 1/2 inches apart or to individual pots.

Planting times. Do not be in a rush to start seeds outdoors or to set out started plants. As a general rule, delay sowing seed of warm-weather annuals outdoors or setting out started plants until after the last frost date. Most such seeds will not germinate well in soils below 60 F. If soil is too cold when seed is sown, seeds will remain dormant until soil warms and may rot instead of germinating. Some cold-loving annuals, like larkspur, should be sown in late fall or very early spring.

Sowing seed outdoors. Annuals seeded in the garden frequently fail to germinate properly because the surface of the soil cakes and prevents entry of water. To avoid this, sow seed in vermiculite-filled furrows. Make furrows in soil about 1/2 inch deep. If soil is dry, water the furrow, then fill it with fine vermiculite and sprinkle with water. Then make another shallow furrow in the vermiculite and sow the seed in this furrow. Sow at the rate recommended on the package. Cover the seed with a layer of vermiculite and, using a nozzle adjusted for a fine mist, water the seeded area thoroughly. Keep the seed bed well-watered or cover with mulch, such as newspaper, to prevent excess evaporation of water. Remove mulch promptly after germination starts, so young seedlings will receive adequate sunlight.

Setting out transplants. By setting seedlings in the garden, a display of flowers arrives several weeks earlier than sown seeds. This is especially useful for germinating annuals (such as verbena) slowly or those that need several months to bloom. You can buy plants of these or other annuals or you can start your own. Buy only healthy plants, free of pests and diseases. Before setting out transplants, harden them off by exposing them to outside conditions during the day, providing more light and cooler temperatures than they received inside. After the last frost date, annual plants may be set out. Dig a hole for each plant large enough to accept its root system comfortably. Lift out each plant from its flat, set in a planting hole and backfill so the plant sets at the same level as they appear in the flat. Irrigate each hole. A water-soluble fertilizer may be used at this time. The type used should be based on a soil test. Follow package directions.

If plants are in fiber pots, remove the paper from the outside of the root mass and set the plant in a prepared planting hole. When setting out plants in peat pots, set the entire pot in the planting hole, but remove the upper edges of the pot so all of the peat pot is covered when soil is firmed around the transplant. If a lip of the peat pot is exposed above the soil level, it may produce a wick effect, pulling water away from the plant and into the air. After setting the plants, water them in and apply fertilizer based on a soil test. Provide protection against excessive sun, wind or cold while the plants are getting settled in their new locations. Inverted pots, newspaper tunnels or cloches can be used.

Watering. Do not rely on summer rainfall to keep flower beds watered. Plan to irrigate them from the beginning. When watering, moisten the entire bed thoroughly, but do not water so heavily that the soil becomes soggy. After watering, allow the soil to dry moderately before watering again. A soaker hose is excellent for watering beds; water from the soaker hose seeps directly into the soil without waste and without splashing leaves and flowers. The slow-moving water does not disturb the soil or reduce its capacity to absorb water. Water wands and drip systems are also good. Sprinklers are not as effective as soaker hoses. Water from sprinklers wets the flowers and foliage, making them susceptible to diseases. The structure of the soil may be destroyed by impact of water drops falling on its surface; it may puddle or crust, preventing free entry of water and air. The least effective method for watering is with a hand-held nozzle. Watering with a nozzle has all the objections of watering with a sprinkler. In addition, gardeners seldom are patient enough to do a thorough job of watering with a nozzle. Not enough water is applied and the water that is applied is usually poorly distributed.

Mulching. Mulches help keep the soil surface from crusting and aids in preventing growth of weeds; organic mulches can add humus to the soil. Grass clippings make a good mulch for annuals, if they do not mat. In general, only a thin layer of mulch may be needed in annual beds. Be careful not to bury or pile mulch up against the base of small plants. Too much mulch may result in rots developing.

Weeding (cultivating). After plants are set out or thinned, cultivate only to break crusts on

the surface of the soil. When the plants begin to grow, stop cultivating and pull weeds by hand. As annual plants grow, feeder roots spread between the plants; cultivation is likely to injure these roots. In addition, cultivation stirs the soil and uncovers weed seeds that then germinate.

Deadheading (removing old flowers). To maintain vigorous growth of plants and assure neatness, remove spent flowers and seed pods. This step is particularly desirable if you are growing ageratum, calendula, cosmos, marigold, pansy, scabiosa or zinnia.

Staking. Tall-growing annuals like larkspur or tall varieties of marigold or cosmos need support to protect them from strong winds and rain (Figure 6.25). Tall plants are supported by stakes of wood, bamboo or reed large enough to hold the plants upright, but not large enough to be conspicuous. Stakes should be about 6 inches shorter than the mature plant so their presence will not interfere with the beauty of the bloom. Begin staking when plants are about 1/3 their mature size. Place stakes close to the plant, but take care not to damage the root system. Secure the stems of the plants to stakes in several places with twine or other materials that will not cut into the stem. Plants with delicate stems can be supported by a framework of stakes and strings in criss-crossing patterns.

Fertilizing. When preparing beds for annuals, fertilizer should be added according to recommendations given by soil sample analysis or derived from observation of plants grown on the site. Lime may also be needed if the soil test results indicate it. Use dolomitic limestone rather than hydrated lime. Ideally, lime should be added in the fall so it will have time to change the pH. Fertilizer should be added in the spring so it will not leach out before plants can benefit from it.

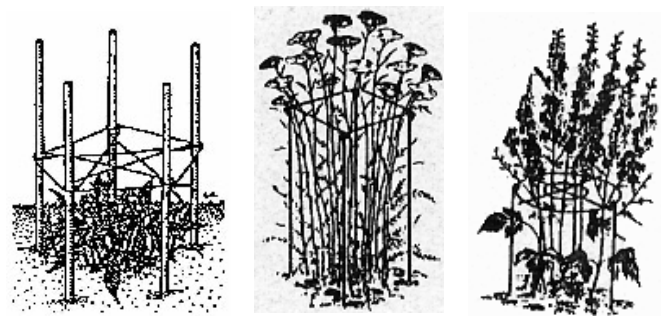

Figure 6.25. Examples of staking material used to support tall plants.

Once annuals have germinated and begin to grow, additional fertilizers may be needed. This is especially true if organic mulches are added because microorganisms decomposing the mulch take up available nitrogen; in these situations additional nitrogen may be needed. Be sure to work the fertilizer in around the plants in such a way as to avoid direct contact between the stems and the fertilizer. Apply fertilizers to damp soil.

Controlling insects and diseases

Insect Pests. Do not apply an insecticide unless it is necessary to prevent damage to plants. Most insect pests in the garden will not cause appreciable damage if their predators and parasites are protected by avoiding unnecessary applications of insecticides. However, if there is a pest that usually causes serious damage unless an insecticide is used, apply the insecticide as soon as the infestation appears and begins to increase. When possible, use an insecticide more specific to the pest to be controlled rather than a broad spectrum insecticide; this will reduce the inadvertent kill of beneficial insects.

Watch for such insect pests as spider mites, aphids, Japanese beetles and other beetles, lacebugs and thrips. These are some of the insects most likely to need prompt treatment with alternative methods of control or insecticides when other methods do not work. Do not treat for soil insects unless you find high numbers of cutworms, white grubs or wireworms when preparing the soil for planting.

When using a pesticide, be certain that the pest and the plant are indicated on the label.

Read and follow all directions for use, including precautions shown on the label. If pesticides are handled, applied or disposed of improperly, they may be injurious to human beings, animals and fish as well as to plants and beneficial



Figure 6.26. Marigolds covered with spider mites.

insects. Use pesticides only when needed and handle them with care.

Diseases. Since annuals only grow in the garden for one season, diseases are not as serious a problem as they are for perennials. Select varieties of plants resistant to disease and follow recommended practices for planting and maintaining annuals and to avoid most disease problems. However, there are times when weather conditions are highly favorable for diseases. If this happens, determine what disease is affecting the plants, then apply the appropriate pesticide according to label directions.

Soil moisture and temperature necessary for germination of seeds are also ideal for development of damping-off. Damping-off causes seeds to rot and seedlings to collapse and die. The disease is carried in soil and may be present on planting containers and tools. Once the disease appears in a seed flat, it may travel quickly through the flat and kill all seedlings planted there. This can be prevented. Before planting, treat the seed with a fungicide and use sterile soil and containers.

Unless you use artificial soilless mixes, sterilize the soil in an oven. Fill a metal tray with moist, but not wet, soil. Hold it at 180 F for 30 minutes. This will produce an unpleasant smell. Do not overheat.

To avoid introducing the damping-off organism on containers, use sterile containers. Peat pots can be set out in the garden along with the plants they contain; roots of the plants grow through the walls of the pots. Plants grown in peat pots suffer no setback when they are transplanted to the garden. Plants that ordinarily do not tolerate transplanting can be grown in peat pots satisfactorily. If wooden boxes or clay flower pots are used for soil containers, clean them well. Soak clay pots in water and scrub them to remove all the white fertilizer crust from the outside. Sterilize clay pots by swabbing them with a solution of one part chlorine bleach to 10 parts water. Allow containers to dry thoroughly before filling them with soil. If damping-off appears in seedlings despite precautions, discard the containers and soil and start again.

Biennials

Biennials are plants that complete their life cycle in two years of growing seasons. During the first growing season, they produce leaves, usually a rosette. In the second growing season, preceded by

a cold period, they produce blooms and die. For the flower gardener, biennials present the obvious disadvantage of producing only foliage the first year and no blooms. For this reason, new varieties have been developed that produce early blooms. Biennial seeds can be sown in midsummer to produce plants developing in the fall, forcing the plant to bloom the next year. Popular biennials are stock and hollyhock. Cultural practices are basically the same as for annuals, except the plants remain two years.

Perennials

Perennials are plants that live year after year. Trees and shrubs are perennial. Most garden flowers are herbaceous perennials. This means the tops of the plants -- the leaves, stems and flowers die back to the ground each fall with the first frost or freeze. The roots persist through the winter and every spring, new plant tops arise. Any plant living through the winter is said to be hardy.

There are advantages to perennials, the most obvious is they do not have to be planted every year like annuals. Some perennials, such as delphiniums, need to be replaced every few years. Another advantage is that with careful planning, a perennial flower bed will change colors, as one type of plant finishes and another variety begins to bloom. In general, most perennials require little care; however, they do require pruning and maintenance to keep them attractive. A few species have a relatively short bloom period, which is a disadvantage, but by combining them with annuals, a continuous colorful show can be provided. Most require transplanting every three years.

Culture and maintenance of perennials

Site location. Consider many of the same aspects of site selection for perennials as do for annuals; sunlight (full sun to heavy shade), slope of the site (affects temperature and drainage), soil type and the role the plants selected will play in the garden. This is especially important with perennials, as they usually are left in place for several years. In general, it is best to plant clumps of perennials rather than one plant. Large plantings may be made if space allows. An ideal location would provide a background such as a wall

or hedge against which perennials will stand out while in bloom. In island beds, perennials can provide their own background if tall ones are planted in the center and low ones toward the edges.

Soil preparation. Preparing the soil is extremely important to perennials. Many annuals can grow and flower in poorly prepared soil, but few perennials survive more than a year if the soil is not properly prepared. Beds dedicated to annuals can also be amended yearly since plantings are not as permanent. Perennial bed soils are more difficult to amend after it is planted.

For new beds, begin preparing soil in the fall before planting time. Have the soil tested first. Results will indicate how much lime or acidifier needs to be added during preparation and how much fertilizer needs to be added in the spring. Materials to adjust pH need time to work. Before preparing new beds, check the soil to see that it is well drained, yet has some water-holding capacity. Test for drainage as described in the section on annuals. If drainage is inadequate, dig furrows along the sides of the bed and add soil from the furrows to the bed. This raises the level of the bed above the general level of the soil. Excess water can then seep from the bed into the furrows. Raised beds may wash during heavy rains. This can be prevented by surrounding the beds with a hardscape material such as wooden or masonry walls. Since raised beds dry out more quickly than flat beds, water beds frequently during the summer. After forming the beds, spade the soil to a depth of 8 or 10 inches. Turn soil over completely, incorporating 2 to 4 inches of organic material. Remove debris and leave rough during the winter.

Just before planting in the spring, spade again. At this spading, add recommended levels of fertilizers. Be sure to work any phosphorous deeply into the soil, where plant roots can get it. Rake the soil surface smooth. After raking, the soil is ready for seeding or planting.

Selecting plants. It is best to select plants with a purpose in mind, such as edging plants, accents for evergreens, masses of color, rock garden specimens, etc. With specific purposes in mind, choose perennials by considering their characteristics and deciding which plants best meet your requirements.

Select named varieties for a good display from a limited number of plants in a limited space. Observe the flowering times of perennials in the

neighborhood. Choose plants that will flower together and plants that will be showy when little else is in bloom. The flowering time may vary as much as six weeks from year to year, but plants of the same kind and their cultivars usually flower at the same time. To obtain details on particular plants or groups of plants, consult plant societies, specialty books, the internet, nurseries that specialize in herbaceous perennials and local botanical gardens.

Plants designated as *Oklahoma Proven* plant selections are tough, attractive and easily grown in most parts of the state. Most are readily available in local nurseries and garden centers. Examples of *Oklahoma Proven* selections are 'Magnus' purple coneflower, autumn sage, giant coneflower, toad lily, hardy plumbago, hellebore and 'Golden Jubilee' anise hyssop. For a complete and updated list of *Oklahoma Proven* plants see <http://oklahomaproven.okstate.edu/>.

Plants of many perennials can be bought at a local nursery. These plants usually are in bloom when offered for sale, which allows selection of the colors desired. Buy compact perennial plants with good foliage color. Plants held in warm shopping areas are seldom vigorous and generally have thin, pale, yellow stems and leaves. Avoid buying these plants. Buy named varieties of plants for known characteristics of disease resistance, heat and cold resistance, growth habits and colors.

Many perennials do not grow true to type if grown from seed saved from old plants. If planting from saved seed, many off-types of color, flower form and plant habit are produced. Purchased seed, whether hybrid or strains, usually give uniform results. Sow perennial seeds directly in the beds where the plants are to bloom, or start early plants indoors or in a cold frame and set them out in beds after the weather warms.

Planting times. Generally, late-summer or fall-flowering perennials are planted in the spring, while spring-flowering perennials are planted in late summer or early fall. However, check exact planting dates for specific perennials. Regardless of the time of planting, perennials should be allowed sufficient time to establish themselves before blooming or the onset of cold weather.

Planting procedure. Perennials are planted in the same way as annuals. For planting details, refer to the annual section of this chapter. Leave

plenty of space between the plants because most perennials spread quickly and need room to develop. Perennials usually show up best when planted in clumps or groups of plants of the same variety.

Watering. Since herbaceous perennials grow back from the roots every year, it is important to encourage healthy, deep roots. Proper watering promotes good root development. When watering, make sure all the roots are reached. Follow directions on watering in the section on annuals. Water occasionally in the winter because the root systems of perennials continue to be active through the dormant season.

Mulching. Mulch gives an orderly look to the garden and cuts down on weeding. Mulches are very useful for maintaining uniform moisture conditions in the garden. Soil temperatures are modified by mulches to various degrees. Organic mulches may add some nutrients and humus to the soil, improving its tilth and moisture-holding capacity. Most organic mulches should be applied after plants are well established and when there is reasonably good soil moisture. Inorganic mulches, such as gravel, permeable landscape fabric or paper are applied prior to planting. Bark, pine needles and shredded leaves are common organic mulches used in perennial beds. All mulches require care to keep them attractive.

Perennials should be mulched during the winter months to protect them from the heaving that results from repeated freezing and thawing of the soil. However, you must be careful with winter mulching, as it can do more harm than good. Be careful not to pile mulch heavily over the crowns, as this would encourage rotting. Boughs of evergreens give ample protection but allow air circulation. Apply mulch around the plants only after the soil temperature has decreased after several killing frosts. If winter mulch is applied too early, the warmth from the protected soil will cause new growth to start. Severe damage to the plant can result from new growth being frozen back. Remove winter mulch as soon as growth starts in the spring. If you don't, new growth will develop abnormally with long, gangly stems and insufficient chlorophyll.

Weeding. Follow weeding directions in the section on annuals. A few preemergent herbicides are now registered for use in perennial flowers.

Fertilizing. Regular fertilization may be necessary. Perennial plantings can rob the soil of its

natural fertility. However, do not fertilize perennials heavily. A light fertilization program gives a continuous supply of nutrients to produce healthy plants. If the soil has not been tested, broadcast the fertilizer through the bed in March; repeat the application twice more at six-week intervals. This should carry the plants through summer. Apply another treatment of fertilizer to late-blooming plants in late summer. Always water the bed after applying fertilizer. This will wash the fertilizer off the foliage and prevent burn. It will also make fertilizer available to the plants immediately.

Deadheading. After perennials have bloomed, spent flowers should be removed. Cut flower stems down to a healthy leaf or to the ground if there are not more buds. This will keep the beds looking neat and will prevent plants from wasting energy setting seed. Some plants can be forced to rebloom if cut back severely after the first bloom. Other perennials, such as salvia, benefit from occasional shearing to keep them more compact and bushy, reducing the need for staking.

Disbudding. To gain large blooms from perennials, as opposed to more numerous, but smaller blooms, disbud them. In disbudding, small side buds are removed, which allows the plant to concentrate its energy to produce one or a few large blooms. Peonies and chrysanthemums are examples of plants that are often disbudded (Figure 6.27).

Staking. Most erect perennials are top-heavy and all of the taller ones need staking. If plants fall over, the stem will function poorly where it has

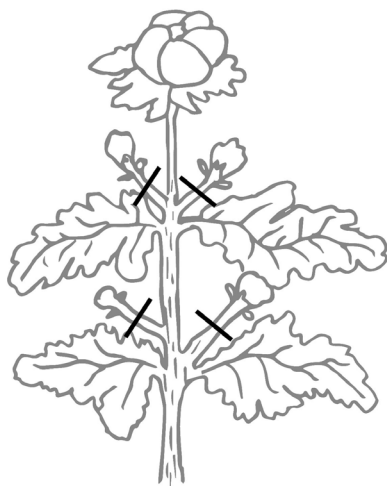

Figure 6.27. Disbudding entails removing small side buds which compete with the terminal flower.

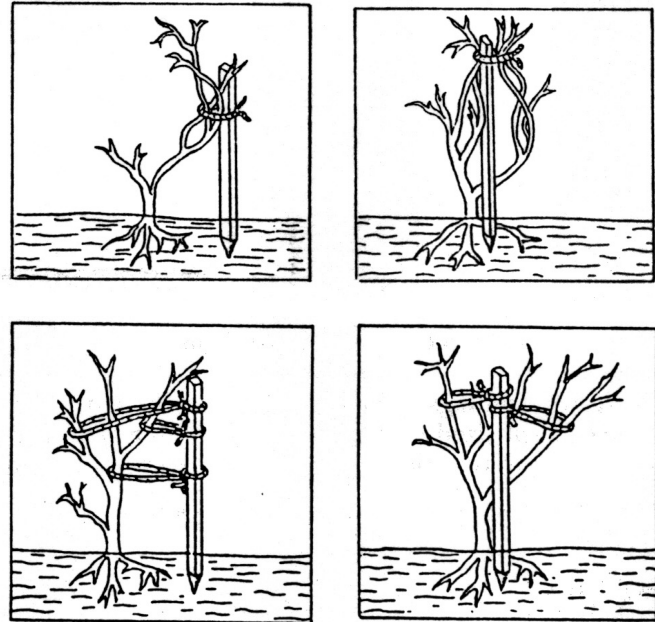

Figure 6.28. The plants in the illustrations in top have been tied too tightly. It is better to tie the principal branches loosely as shown in the illustrations on the bottom.

been bent. If the stem is cracked, disease organisms can penetrate the break. Stake plants when planting, so they will grow to cover the stakes. Once staked, tall perennials can better withstand hard, driving rain and wind.

Use stakes made of any material. Select stakes that will be 6 to 12 inches shorter than the height of the grown plant. Place stakes behind the plants and sink them into the ground far enough to be firm. Loosely tie plants to the stakes with strings, plastic or other soft material (Figure 6.28). Tie the plant by making a double loop of the string with one loop around the plant and the other around the stake. Never loop the tie around both stake and plant. The plant will hang to one side and the string may girdle the stem. Add ties as the stem lengthens.

Fall Care. After the foliage of perennials has died down in the fall, remove dead leaves, stems and spent flowers if insects and disease-causing organisms have been present. Otherwise, plants can be left alone until late winter/early spring. At that time, just prior to new spring growth, remove dead plant material. Leaving old foliage on the plant through winter provides a natural mulch, protecting the crown of the plant from harsh winter conditions. In addition, some perennials, such as ornamental grasses, provide winter interest and

sometimes food for wildlife. Apply winter mulch after the soil temperature has dropped.

Controlling insects and diseases

Perennials can occasionally have some pest problems. It is advisable to select resistant varieties. Planting perennials in conditions of light, wind, spacing and soil textures that are suited to them will help reduce possible pest problems. Remove spent flowers, dead leaves and other plant litter, as these serve as a source of reinfestation. It is advisable to know the major insect and disease pests (if any) of each specific plant type grown, so problems can be correctly diagnosed and treated as they arise.

Asexual propagation of perennials

Division. Most perennials left in the same place for more than three years are likely to be overgrown, overcrowded, have dead or unsightly centers and in need of basic feeding and soil amendment. The center of the clump will grow poorly, if at all, and the flowers will be sparse. The clump will deplete the fertility of the soil as the plant crowds itself. To divide mature clumps of perennials (Figure 6.29), select only vigorous side shoots from the outer part of the clump. Discard the center of the clump. Divide the plant into clumps of three to five shoots each. Be careful not to over-divide; too small a clump will not give much color the first year after replanting. Divide perennials when the plants are dormant, just before a new season of growth, or in the fall so they can become established before the ground freezes.

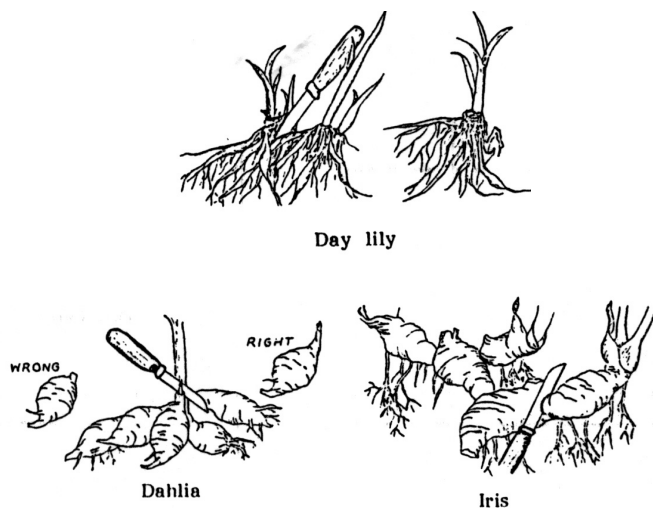

Figure 6.29. Examples of dividing perennials.

Stagger plant divisions so the whole garden will not be redone at the same time; good rotation will yield a display of flowers each year. Do not put all the divisions back into the same space that contained the original plant. That would place too many plants in a given area. Give extra plants to friends, plant them elsewhere in the yard, or discard them.

Cuttings. Many plants can be propagated from either tip or root cuttings. Generally, tip cuttings are easier to propagate than root cuttings. Make tip cuttings 3 to 6 inches long. Treat the base of the cutting with a rooting hormone. Leave all foliage on the cutting except the part that will be below the soil line. Place containers of cuttings in a lightly shaded place and cover with a sheet of clear plastic. Check regularly to make sure the cuttings do not dry out.

When cuttings do not pull easily out of the soil, they have begun to root. Make holes in the plastic sheet to increase the exposure of the cuttings to the air; this hardens them. Every few days make new holes or enlarge the existing holes.

Some plants, such as phlox, baby's-breath and Oriental poppy, are best started by root cuttings. Dig the plants in late summer after they have bloomed. Select pencil-sized roots and cut them into 4-inch sections. Put each piece in a rooting medium.

Bulbs

The term bulb is used to include true bulbs, corms, tubers, tuberous roots and rhizomes.

A true bulb is a complete or nearly complete miniature of a plant encased in fleshy modified leaves called scales that contain reserves of food.

Corms are the base of a stem that becomes swollen and solid with nutrients. It has no fleshy scales.

The tuber is an underground stem that stores food. It differs from the true bulb or corm because it has no covering of dry leaves and no basal plant from which the roots grow. Usually short, fat and rounded tubers have a knobby surface with growth buds, or eyes, from which the shoots of the new plant emerge.

A tuberous root is the only bulb form that is a real root. Its food supply is kept in root tissue, not in stem or leaf tissue as in other bulbs.

Rhizomes, sometimes called rootstocks, are thickened stems that grow horizontally, weaving their way along or below the surface of the soil and at intervals sending stems above ground.

Many vegetables are propagated from or produce edible organs from one of these types of bulbs (e.g., tuber – Irish potato; tuberous root – sweet potato; rhizome – Jerusalem artichoke; bulb – onion).

Bulbs are broadly grouped into spring flowering (January to May) and summer-flowering (June to September). Spring bulbs provide early color before most annuals and perennials. One of the most popular spring bulbs is the tulip. However, in most areas of Oklahoma, tulips should be treated as annuals. Because of the state's relatively hot springs and mild winters, only a few tulip varieties return for a second or third year; some tulip species can perennialize in parts of Oklahoma.

Tulips come in all colors except blue and are sold by type and variety. Some of the most common types are:

Breeder:	Bronzed, not clear colors
Cottage:	Late-blooming
Darwin:	Tallest; wide flower
Lily flowered:	Petals recurved – bell-shape
Parrot:	Twisted, ruffled petals
Double:	Two or more rows of petals

Narcissus, daffodils and jonquils are classed by length of corolla in relation to perianth segments. They come in the colors of white, yellow, red and peach. Many have naturalized in places.

Hyacinths produce a large single spike of many small, fragrant flowers and come in a complete color range. These also are treated as annuals.

Crocuses are usually grown for early bloom (in snow). There are no red crocuses.

Selecting quality spring bulbs is very important, because the flower bud has already developed before the bulb is sold. Size is also important; look for plump, firm bulbs. Select on a basis of color and size for intended purposes; for example, small ones for naturalizing and large ones to stand out as specimen plants. Keep cool (60 F to 65 F) until planting, except for tulips, which should be kept at 40 F to 45 F.

The summer-flowering bulbs include amaryllis, tuberous begonia, caladium, day lily, dahlia, gladiolus, lily and spider lily. Most perform as hardy pe-

rennials with roots that survive the winter. However, caladiums and dahlias may need to be dug up and stored or bought and planted each year.

Culture and maintenance of bulbs

Storage. If bulbs are bought before planting time, keep them in a cool, dry place. A temperature of 60 F to 65 F is cool enough to prevent bulbs from drying out until time for planting. Temperatures higher than 70 F will damage the flower inside spring-flowering bulbs. Rhizomes, tubers and tuberous roots are more easily desiccated than bulbs and corms, and should be stored in peat, perlite or vermiculite.

Site Selection. In selecting a site for planting, consider light, temperature, soil texture and function. Most bulbs need full sun. Select a planting site providing at least five to six hours of direct sunlight a day. Bulbs left in the ground year after year should have eight to 10 hours of daily sunlight for good flowering. Bulbs planted in a southern exposure near a building or wall will bloom earlier than bulbs planted in a northern exposure. Adequate drainage is an important consideration. Most bulbs and bulb-like plants will not tolerate poor drainage and will rot easily if planted in wet areas. Function must also be kept in mind. If bulbs are being used to naturalize an area, toss the bulbs then plant them where they fall to create a scattered effect.

Site Preparation. Good drainage is the most important single factor for successful bulb growing. Dig bulb beds when the soil is fairly dry. Wet soil packs tightly and retards plant growth. Spade the soil 8 to 12 inches deep. Remove large stones and building trash, but turn under all leaves, grass, stems, roots and anything else that will decay. Add fertilizer to the soil as determined by a soil test. Place a 1- to 2-inch layer of organic matter on the bed. Thoroughly mix the fertilizer and organic matter with the soil.

Time of Planting. Hardy, spring-flowering bulbs are planted in early fall. Hardy, fall-flowering bulbs, such as colchicum, are planted in August. Tender, summer-flowering bulbs are planted in the spring after danger of frost. Lilies are best planted in late fall.

Depth of Planting. It is best to check correct planting depth for each bulb with a successful local grower or other good local source. Depending on soil condition, bulb catalog and reference book recommendations for planting may be either

too shallow or too deep. In general, bulbs should be planted 2 1/2 to 3 times the diameter of the bulb in depth. In clay soils, shallower planting depths are often recommended. It is important not to plant bulbs too shallow, as this will encourage frost heaving.

Watering. Normal rainfall usually provides enough moisture for bulbs. But during dry weather, water plants at weekly intervals, soaking the ground thoroughly. Be especially careful not to neglect bulbs after blooming.

Mulching. In the winter, mulch bulbs 2 to 4 inches deep with organic material such as straw, pine bark, hay or ground leaves. Do not use large leaves, as they may mat too tightly on the ground. A winter mulch prevents alternate freezing and thawing, which damages bulbs and plant roots. Apply mulch after cold weather arrives. If soil temperature is too high, the bulbs may be damaged. Remove mulch as soon as danger of severe freezing has passed, in early spring. If mulch is left on the ground after new growth starts, tops of new shoots will be pale green or colorless and new stems and foliage may be broken.

Fertilizing. After plants bloom, fertilize them lightly with a balanced fertilizer. Avoid high-nitrogen fertilizer. Be sure to keep fertilizer off the leaves and away from roots; it will burn them. Often, bone-meal is recommended as an extra source of phosphorus, but is not needed in most Oklahoma soils because phosphorus is generally adequate.

Staking. Some tall, heavy-flowered bulbs may require staking. Stake plants when they are emerging, but be careful not to damage the bulb

with the stake. For flowers that face one direction, use the stake to orient the face to the front of the bed.

Deadheading. When flowers fade, cut them off to prevent seed formation. Seeds take stored food from the bulbs.

Moving. If leaving bulbs in place for bloom next year, do not cut the leaves after flowering until they start to wither. Green leaves produce food for plant growth next year. After leaves turn yellow, cut and destroy the stems and foliage of the plants. Dead foliage left on the ground may carry disease to new growth the next year. If moving bulbs from one place to another or thinning, do so only after the foliage has faded.

Digging and Storing. Many tender summer-flowering bulbs should be dug and stored. This is done when the leaves on the plants turn yellow. Use a spading fork to lift the bulbs from the ground. Wash off any soil that clings to the bulbs, except those stored in pots or with the soil around them. Spread the washed bulbs in a shaded place to dry. When dry, store them away from sunlight in a cool, dry basement, cellar, garage or shed at 60 F to 65 F. Avoid temperatures below 50 F or above 70 F. Be sure air circulates around stored bulbs. Never store bulbs more than two or three layers deep, as they generate heat and cause decay. Leave the soil on begonia, canna, caladium, dahlia and hyacinth bulbs. Store these bulbs in clumps on a slightly moistened layer of peat moss or sawdust in a cool place. Rinse, clean and separate them just before planting.

Selecting Annuals, Perennials and Bulbs

Table 6.2. Partial list of Annual Flowers for Oklahoma

<i>Botanical and Common Name</i>	<i>Habit</i>	<i>Flower colors</i>	<i>Culture</i>	<i>Comments</i>
<i>Abelmoschus moschatus</i> Annual Hibiscus	18 in. mounded cherry-red	Pink, red, scarlet,	Sun, part shade, moist well-drained soil, tolerates heat	Bed, edging, containers
<i>Acalypha wilkesiana</i> Copperleaf	2-6ft.	Colorful foliage – red, purple, pink, crimson, orange	Full sun	Background, specimen; thrives in hot climates
<i>Acmella oleracea</i> 'Peek-a-boo' Spilanthes	12-15 in. h, 24-30 in. w	Yellow with red eye	Full sun, part shade, moist well- drained soil	Groundcover, container, bedding, purplish foliage; also known as toothache plant
<i>Agave desmettiana</i> 'Variegata' Variegated agave	2-3 ft. h, 3-4 ft.	Yellow, appear at end of life cycle; noted for striking foliage	Full sun to part shade; well- drained soil. Drought tolerant	Accent plant, container
<i>Ageratum houstonianum</i> Mexican Ageratum, Flossflower	4-12 in., mound-like	Lavender, blue, pink, white	Sun, part shade	Edging, border
<i>Alternanthera ficoidea</i> Garden Alternanthera, Joseph's Coat <i>Amaranthus tricolor</i> Joseph's Coat Amaranth, Fountain Plant	6-12 in., rounded 1 ½-5 ft. high	Colorful leaves Colorful foliage and flowers	Sun, most soils Sun, average to dry soil	Can be sheared, carpet, edging Background, specimen
<i>Angelonia angustifolia</i> Angel flower, summer snapdragon <i>Antirrhinum majus</i> Snapdragon	18-24 in. high 6 in.-4 ft.	Purple, white, pink Red, pink, yellow, orange, bronze, lavender	Sun, heat loving Sun, part shade, well-drained soil; prefers cooler temps	Cut, border, bed, mass, container, specimen Cut, border, bed, edging

Table 6.2. Partial list of Annual Flowers for Oklahoma (cont'd).

<i>Botanical and Common Name</i>	<i>Habit</i>	<i>Flower colors</i>	<i>Culture</i>	<i>Comments</i>
<i>Basella alba</i> Malabar spinach	Trailing vine	Not showy; red stem varieties, glossy green leaves	Sun, hot humid weather	Trellis, arbor; edible
<i>Begonia semperflorens-cultorum</i> Fibrous-rooted Begonia, Wax Begonia	6-16 in. round	White to shades of red or pink	Shade, full sun if moist	Planters, edging, carpet, indoor
<i>Brassica oleracea acephala</i> Ornamental Kale; <i>B. oleracea capitata</i> Ornamental Cabbage	10-15 in. tall with rosette leaves	Not important; leaves blue-green tinged with pink, red, or purple	Full sun, prefers moist, well-drained soil. Low nitrogen rates increase foliage color. Cool season.	Many cultivars. Bedding plant, carpet garden, and specimen.
<i>Browallia speciosa</i> Browallia, Amethyst Flower, Sapphire Flower	8-16 in. round	Blue or white	Shade to partial shade; avoid over-watering or over-fertilizing	Shade bedding, window boxes, planters, trailing
<i>Calibrachoa</i> hybrids Million Bells	3 ft. 12 in. h., 6-24 in. w	White, pinks, reds, violet, yellow, or orange	Full sun, well-drained moist soil	Planters, edging, border; does not need deadheading
<i>Capsicum annuum</i> Bush Red Pepper, Ornamental Pepper	10-20 in., rounded	Colorful fruits and sometimes foliage	Sun, moist, good organic matter	Bed, edging, border, carpet beds
<i>Catharanthus roseus</i> Madagascar Periwinkle, Rose Periwinkle	3-18 in. h., prostrate to upright	Rose-pink, mauve, white	Sun, part shade, moist, well-drained soil, heat tolerant	Border, bed, groundcover; use disease resistant varieties
<i>Celosia cristata</i> Crested Cockscomb types; Plume Cockscomb types, Feathered Amaranth	6-24 in.	Red, yellow, gold, orange, pink	Sun, tolerates dry, porous soil	Cut, border, edging, bed, dried

Table 6.2. Partial list of Annual Flowers for Oklahoma (cont'd).

<i>Botanical and Common Name</i>	<i>Habit</i>	<i>Flower colors</i>	<i>Culture</i>	<i>Comments</i>
<i>Centaurea cyanus</i> Bachelor's-button, Cornflower borders or beds, bouquets	15-36 in.	Mahogany, red, mauve, pink, deep blue, white	Full sun, well-drained soil; tolerates dry conditions	Massed in
<i>Cleome hasslerana</i> Cleome, Spider Flower	2-4 ft. high	Cherry, pink, rose, violet, white, rose-purple	Sun, part shade	Background, cut.
<i>Clitoria ternatea</i> Blue pea; Butterfly pea	10-15 ft., twining vine	Royal blue, light blue, dark blue, purple, white	Sun to part shade	Moist, well-drained soil
<i>Cobaea scandens</i> Cup-and-saucer Vine	20 ft., self-climber	Violet to deep purple	Full sun to part shade	Sweet honey scent
<i>Coleus x hybridus</i> (<i>Solenostemon scutellarioides</i>) Coleus	9-18 in.	Colorful foliage; many cultivars	Sun or light shade, well-drained, moist soil	Edging, border, planters, bed, indoor plant
<i>Cosmos bipinnatus</i> Cosmos	3-6 ft.	Red, pink, white, violet, lavender	Sun, tolerates dry soils, don't over fertilize.	Background, cut; reseeds
<i>Cosmos sulphureus</i> Yellow Cosmos, Klondike Cosmos, Orange Cosmos	12-36 in.	Varies by cultivars, from yellow to orange and scarlet	Sun, tolerates dry, porous soil.	Background or cut
<i>Cuphea hyssopifolia</i> Mexican heather	8-15 in. high, 10-15 in. wide	Purple, pink, or white	Well-drained soils; poor soils okay. Sun to part shade	Container, rock garden, walkways, bed
<i>Cuphea ignea</i> Cuphea, Firecracker plant, Cigar Plant	18-30 in. high and wide	Orange-red, many cultivars exist as well as related species	Heat tolerant; tolerates part shade. Well-drained soil.	Borders, edging, containers, hanging baskets, houseplant. Attracts hummingbirds and butterflies.
<i>Cuphea x purpurea</i> Cigar Plant	10-20 in.	Red, scarlet	Sun, light shade	Edging, borders, window boxes, planters, rock gardens
<i>Dahlia</i> hybrids Garden Dahlia	1-5 ft., round to erect	Varies with cultivar	Sun, part shade, well-drained moist soil	Bed, cut

Table 6.2. Partial list of Annual Flowers for Oklahoma (cont'd).

<i>Botanical and Common Name</i>	<i>Habit</i>	<i>Flower colors</i>	<i>Culture</i>	<i>Comments</i>
<i>Dianthus caryophyllus</i> Annual Carnation	1-2 ft. erect plant	White, pink, red, purple, yellow, or apricot-orange	Prefers cool temperatures; moist well drained soil; best in neutral to slightly basic pH soils.	Cut flower, bedding
<i>Dianthus chinensis</i> China Pinks, Rainbow Pinks	6-12 in. mounded habit	Red, pink, white, and bicolored	Sun to part shade, prefers cool temperatures; thrives in high pH soils.	Edging, bedding
<i>Dichondra argentea</i> 'Silver Falls' Silver Falls dichondra	2 in. high, 3-4 ft. wide, mat forming	Silver foliage	Sun, well-drained soil; very drought tolerant	Groundcover, edging, containers
<i>Dyssodia tenuiloba</i> Dahlberg Daisy, Golden-fleece	6-8 in. tall, 15-18 in. wide	Yellow disk flowers, golden-yellow-orange ray flowers	Full sun, well-drained soil; takes heat well	Edging, bedding, hanging basket
<i>Eschscholzia californica</i> California Poppy	12-15 in.	Deep orange, pale yellow, bronze, scarlet, rose, white	Sun, well-drained sandy soil, dry	Bed, border, naturalized
<i>Euphorbia 'Inneuphdia'</i> Diamond Frost® euphorbia	Mounded, 12-18 in.	White	Dry to normal; sun to part shade	Rock garden, container, bed, heat and drought tolerant
<i>Euphorbia marginata</i> Snow-on-the-mountain	Mounded, 1-4 ft.	White margined bracts	Dry to normal; sun	Bed, native, heat and drought tolerant
<i>Evolvulus glomeratus</i> Blue daze	6-12 in. spreading 2-3 ft.	Blue	Moist well-drained soil	Edging, rock garden, groundcover, bed
<i>Gaillardia pulchella</i> Blanket flower, Indian blanket	1 ½-2 ft.	Yellow, orange, red, scarlet	Sun, withstands drought, wind	Cut flower, bed, window boxes, planters
<i>Gazania rigens</i> Gazania, Treasure Flower	6-12 in.	Orange, yellow, red, pink	Sun, tolerates light & sandy soils	Border, bed, edging; flowers close on cloudy days
<i>Gomphrena globosa</i> Gomphrena, Globe Amaranth	9-24 ft., rounded	Purple, white, pink, yellow	Sun, well-drained soil; tolerates heat, wind, rain	Cut, dried, bed, edging, mass
<i>Gomphrena haageana</i> 'Strawberry Fields' Globe Amaranth, Button Flower	Upright, bushy, 24 in.	Red	Sun, well-drained soil; tolerates heat, wind, rain	Cut, dried, bed, edging, mass

Table 6.2. Partial list of Annual Flowers for Oklahoma (cont'd).

<i>Botanical and Common Name</i>	<i>Habit</i>	<i>Flower colors</i>	<i>Culture</i>	<i>Comments</i>
<i>Hamelia patens</i> Firebush	3-4 ft. shrubby	Orange-red	Sun, tolerates heat, humidity, dry conditions, most soils	Background, hummingbird, specimen; tender shrub
<i>Helianthus annuus</i> Common Sunflower	2-10 ft.	White, yellow, lemon-yellow, apricot-orange, orange-yellow, red, purple	Sun, tolerates heat, dry conditions, almost any soil	Background, winter bird food
<i>Helichrysum bracteatum</i> Strawflower	18-36 in. tall, round to erect	Yellow, orange, red, salmon, rose, white, or purple	Sun and well-drained, moist soil	Fresh cut or dried flower
<i>Hypoestes phyllostachya</i> Polka-dot Plant	1-2 ft. high, 1 ft. wide	Lavender; leaves also attractive, dark green with lavender-pink spots	Full sun, part shade; moist, well-drained soil	Mass display, indoor foliage plant
<i>Impatiens balsamina</i> Garden Balsam, Touch-Me-Not	8-36 in.	White to yellow, pink purple, or dark red	Sun or shade, moist, light sandy loam soil.	Bedding, edging, borders
<i>Impatiens hawkeri</i> New Guinea Impatiens	8-24 in., upright or spreading	Lavender, purple, pink, red, orange	Part shade, ample moisture	Hanging basket, pot
<i>Impatiens wallerana</i> Sultana, Impatiens	6-18 in., compact, mounded	All colors, bicolors	Shade, part shade, sun if moist	Shaded areas, planters, hanging baskets
<i>Ipomoea batatas</i> Ornamental sweet potato	4-6 ft. vine, spreading	Foliage colors, shapes	Sun	Groundcover, hanging basket, container
<i>Ipomoea lobata</i> Firecracker vine; Spanish flag	8-15 ft., vine	Orange-scarlet, fading to yellow then white	Sun	Screen, trellis, arbor
<i>Ipomoea purpurea</i> Morning-glory	8-10 ft., twining vine	Purple, blue, pink, white	Sun, well-drained soil	Screen, trellis. Reseeds
<i>Ipomoea quamoclit</i> Cypress Vine	8-10 ft. vine almost fern-like	Scarlet. Leaves deeply cut,	Sun	Attracts hummingbirds; may reseed

Table 6.2. Partial list of Annual Flowers for Oklahoma (cont'd).

<i>Botanical and Common Name</i>	<i>Habit</i>	<i>Flower colors</i>	<i>Culture</i>	<i>Comments</i>
<i>Justicia brandegeana</i> shrimp plant; also golden shrimp plant (<i>Pachystachys lutea</i>)	2-3 ft. high, 18-24 in. wide	Red, orange, yellow, white	Full sun to part shade. Fertile, organic soils, but tolerate poor or sandy soils	Container, bed, specimen
<i>Lantana</i> hybrids <i>Lantana</i>	1 ½-4 ft.	Yellow, orange, red, magenta, pink, purple	Full sun	Beds, hanging baskets, planters
<i>Lobelia cardinalis</i> Cardinal flower	2-3 ft., erect	Scarlet, pink, white	Part shade, moist soil	Container, bed
<i>Lobelia erinus</i> <i>Lobelia</i>	4-8 in., round or spreading	Blue, white, carmine-red, purple-red, crimson, lilac, rose	Part shade, adequate moisture; performs best in cooler temps	Edging, ground cover, rock gardens, hanging baskets, window boxes
<i>Lobularia maritima</i> Sweet Alyssum	4-8 in. tall, 10-15 in. spread	White, pink, lavender, purple	Sun, part shade, well-drained soil; prefers cooler temps	Edging, rock garden, massing, pots
<i>Mecardonia</i> hybrids <i>Mecardonia Golddust™</i>	5 in. high, 12-16 in. wide	Yellow	Heat tolerant, well-drained, moist soil	Edging, hanging basket, groundcover
<i>Melampodium paludosum</i> (<i>leucanthum</i>) Blackfoot Daisy	12 in., bushy	Yellow	Sun, well-drained soil	Bed
<i>Melinis nerviglumis</i> 'Savannah' Pink Crystals Ruby grass	18-24 in., clump forming	Ruby-pink, blue-green foliage	Sun, hot and dry	Beds, mixed borders, containers, rock garden, good cut flower
<i>Mirabilis jalapa</i> Four-O'clock, Marvel of Peru, Beauty-of-the-Night	18-30 in.	White, red, yellow, pink, or striped	Sun to part shade, tolerant of most soils, heat tolerant	Border
<i>Nicotiana glauca</i> Flowering Tobacco, Ornamental Tobacco (<i>N. sylvestris</i> to 5 ft. tall)	12-24 in. clump attains round growth habit	White, lavender, crimson, maroon, green, pink, lime, yellow	Sun or part shade, moist well-drained soil	Border, bedding, cut

Table 6.2. Partial list of Annual Flowers for Oklahoma (cont'd).

<i>Botanical and Common Name</i>	<i>Habit</i>	<i>Flower colors</i>	<i>Culture</i>	<i>Comments</i>
<i>Nierembergia hippomanica</i> var. <i>violacea</i> Nierembergia, Cup Flower	6-9 in., round	Violet blue, purple, white	Sun, light shade	Edging, window boxes, rock gardens
<i>Ocimum basilicum</i> Basil (many cultivars)	1-2 ft. tall, rounded habit	White or purplish; cultivars with interesting leaf texture and colors	Full sun, moist, well-drained soil	Culinary, borders, beds, pots, and window boxes
<i>Pelargonium peltatum</i> Ivy-leaved Geranium	Vine-like in habit, 1-2 ft. high, 1-3 ft. wide	Pink, red, white, lavender	Full sun to part shade; drought tolerant	Hanging basket, window boxes
<i>Pelargonium x hortorum</i> Geranium, Zonal Geranium, Bedding Geranium	12-20 in., round	Red, pink, salmon, white	Sun, part shade	Moist, well-drained soil with cool root zone
<i>Pennisetum setaceum</i> 'Rubrum' Annual Purple Fountain Grass	3-4 ft., mound to upright arching	Pink or purple, purple leaves	Sun, part shade; somewhat drought tolerant	Border, background, specimen, fresh flower arrangements. Many new cultivars – Fireworks, Prince, Princess, Vertigo®
<i>Pentas lanceolata</i> Star Clusters, Pentas	1-3 ft.	White, red, lilac, pink	Sun, ample water, fertilizer	Bed, border, butterfly plant
<i>Perilla frutescens</i> Magilla™ Perilla	18-24 in.	Leaves hot pink, dark purple and green	Sun to part shade, moist; heat tolerant	Bed, border, containers. Sterile form of species
<i>Petunia x hybrida</i> Petunia	8-15 in., round, trailing	Many colors, striped, or star-like	Sun, part shade, light well-drained soil	Beds, borders, flower boxes, containers
<i>Phaseolus coccineus</i> Scarlet Runner Bean	8-20 ft., twining vine	Scarlet with white wings	Best in cool nights and full sun	Bean pods mature to purple, usually 9-12 in. long and contain black seeds
<i>Phlox drummondii</i> Annual Phlox, Drummond Phlox	6-8 in. tall, 12 in. wide	Lavender, salmon, red, pink, blue, purple, white, bicolors	Prefers light soil, full sun; tolerates light shade	Bedding, edging, rock garden, window boxes
<i>Plumbago auriculata</i> Cape plumbago	2 ft. h, 2 ft. w	Clear light blue, white	Sun, hot and dry, well-drained soil	Groundcover, retaining wall, container
<i>Portulaca grandiflora</i> Moss Rose, Portulaca, Sun Plant	6-8 in., spreading	Rose, red, yellow, white, orange, cream, striped	Sun, hot and dry	Rock garden, groundcover, edging

Table 6.2. Partial list of Annual Flowers for Oklahoma (cont'd).

<i>Botanical and Common Name</i>	<i>Habit</i>	<i>Flower colors</i>	<i>Culture</i>	<i>Comments</i>
<i>Portulaca oleracea</i> Purslane	6-8 in., spreading	Rose, red, yellow, white, orange, cream, striped	Sun, hot and dry	Rock garden, groundcover, edging
<i>Ricinus communis</i> Castor Bean, Castor-Oil-Plant	5-10 ft.	Grown for leaf texture and color from green, red, bluish-gray, maroon, purplish, or variegated	Open sun and rich, fertile soil. Abundant water and fertilizer.	Large scale plant used for specimen. Seeds poisonous.
<i>Salvia coccinea</i> Texas Salvia, Scarlet Salvia	2-3 ft., upright	Red, white, salmon	Sun, well-drained soil	Mixed border, informal appearance
<i>Salvia farinacea</i> Mealycup Sage, Blue Salvia	2-3 ft. erect	Blue, violet-blue, white	Sun, prefers well-drained, moist soil	Cut, border, bed
<i>Salvia splendens</i> Scarlet Sage, Red Salvia	8-30 in., erect to round	Scarlet, purple, pink, lavender, white	Sun, part shade, well-drained moist soil	Bed border, cut
<i>Scabiosa atropurpurea</i> Pincushion Flower, Sweet Scabious	24-36 in.	Dark purple, pink, white	Average to dry soil, full sun	Bouquets, bedding, cut flower
<i>Scaevola aemula</i> Fan flower	4-6 in., spreading to 3 ft.	Lilac mauve, pink, yellow	Sun, part shade	Bed, edging, hanging basket, groundcover, rock garden
<i>Senecio cineraria</i> Dusty Miller	8-15 in., round	Small yellow, usually grown for silver-white foliage	Sun, dry soil with organic matter	Edging, foliage, specimen, pots
<i>Solanum quitoense</i> Bed-of-Nails	4 ft. h, 4 ft. w	White flowers; interesting, large leaves covered with spines, bright orange fruit	Full sun, moist, well-drained soil; heat tolerant	Fruits are edible; related to potato and tomato
<i>Tagetes erecta</i> American Marigold, African Marigold, Aztec Marigold	10-30 in., erect to round	Yellow to orange	Sun, tolerates dry, prefers moist soil	Cut, background, border, bed, edging

Table 6.2. Partial list of Annual Flowers for Oklahoma (cont'd).

<i>Botanical and Common Name</i>	<i>Habit</i>	<i>Flower colors</i>	<i>Culture</i>	<i>Comments</i>
<i>Tagetes patula</i> Dwarf French Marigold	6-18 in., round	Yellow, orange, red-brown, marked with crimson or maroon	Sun, tolerates dry, prefers moist soil	Edging, bed, cut
<i>Tecoma stans</i> Yellow bells	2-4 ft., bushy	Yellow or orange	Sun, thrives in heat, prefers moist soil	Background, border, bed, container
<i>Thunbergia alata</i> Black-eyed Susan Vine, Clock Vine	8 ft., twining vine	Yellow-orange with dark purple-black throat	Full sun, part shade, moist soil. Prefers cooler temperatures	Vine, trailing plant in containers, screen
<i>Tithonia rotundifolia</i> Mexican Sunflower	4-6 ft., coarse, erect	Orange-scarlet, yellow	Sun, intense heat, dry conditions	Cut, background, screen
<i>Torenia fournieri</i> Wishbone Flower, Torenia	6 in.h, 12 in. with mound	Pink, purple, blue	Partial shade	Shady locations, borders, beds, containers
<i>Tropaeolum majus</i> Nasturtium, Indian Cress	1 ft. tall, 2 ft. wide to 6-8 ft. vine	Orange, yellow, red, white, scarlet, bicolor	Sun, part shade, poor soils	Cut, trellis, hummingbirds
<i>Verbena bonariensis</i> Brazilian verbena, verben-a-on-a-stick	3-4 ft., upright	Rose-violet	Sun, tolerates dry soil; tender perennial, will reseed	Background, border, butterfly garden
<i>Verbena x hybrida</i> Garden Verbena	12 in., upright or spreading	White, pink, red, blue, lavender, purple	Sun, well-drained soil	Ground cover, bed, edging, rock garden, window box, hanging basket; select mildew resistant varieties
<i>Viola x wittrockiana</i> Pansy	4-8 in.	Purple, white, blue, dark red, rose, sienna, apricot, brown, yellow, combinations	Sun, part shade; cool moist well-drained soil	Border, edging, window box, cut, bed; best planted in Oct.-Nov.
<i>Zinnia angustifolia</i> Narrow-leaf Zinnia	6-12 in., spreading	White, gold, orange	Sun, well-drained soil	Ground cover, edging, border
<i>Zinnia elegans</i> Zinnia	10-36 in.	Rose, apricot, red, white, violet, pale yellow, green, orange, bicolors	Sun, hot, dry	Border, edging, cut, bed; disease resistant
<i>Zinnia marylandica</i> Zahara series	6-18 in.	Orange, red-orange, red, pink, scarlet, yellow, white	Sun, hot, dry	Border, edging, cut, bed; disease resistant

Table 6.3. A Partial List of Perennial Flowers for Oklahoma

<i>Botanical and Common Name</i>	<i>Habit</i>	<i>Flower/ foliage colors</i>	<i>Bloom Time</i>	<i>Culture</i>	<i>Comments</i>
Shade perennials					
<i>Acanthus mollis</i> bear's breach	3-4 ft.	Purple, white	Late spring to early summer	Shade-part shade.	Shade garden, texture plant.
<i>Aegopodium podagraria</i> bishop's weed	8-10 in.	White - ns, foliage green with white margins	Late spring to early summer	Shade.	Groundcover; can be invasive, cut back old foliage with mower.
<i>Ajuga reptans</i> carpet bugleweed	6-9 in. mat-like	Violet-blue, red, white or purple	Spring	Sun, shade, tolerates poor soil.	Groundcover.
<i>Alchemilla mollis</i> Lady's Mantle	8-10 in. tall (flower stems up to 18 in.), 24 in. wide	Yellowish-green or chartreuse	Late spring to early summer	Part shade; moist, fertile soil.	Border, ground cover, rock garden, cut flower.
<i>Anemone x hybrida</i> Japanese anemone	2-4 ft.	White or pink	Late summer and fall	Morning sun, part shade; fertile, moist, well-drained soil.	Border, woodland.
<i>Aquilegia</i> spp. columbine	1-3 ft. erect	Blue, purple, pink, red, yellow, white	Late spring to early summer	Full sun to part shade; excellent drainage.	Borders, naturalized settings, cut.
<i>Arum italicum</i> Italian Arum	12-18 in. clump	Whitish-green spotted with purple	Late spring	Full to part shade; keep moist spring/early summer.	Borders, naturalized settings; orange-red berries.
<i>Athyrium nipponicum</i> 'Pictum' Japanese painted fern	2-18 in., 1 clump	NS, foliage coarsely divided, gray to glaucous hue		Part to full shade, moist humus-rich soil; do not allow to dry.	Border, accent.
<i>Bletilla striata</i> hardy orchid	Stiffly upright, 12" tall, 9" wide	Purplish pink	Spring	Part shade, moist, organic amended soil; do not let dry out.	Border, rock garden, containers.

Table 6.3. A Partial List of Perennial Flowers for Oklahoma (cont'd)

<i>Botanical and Common Name</i>	<i>Habit</i>	<i>Flower/ foliage colors</i>	<i>Bloom Time</i>	<i>Culture</i>	<i>Comments</i>
<i>Brunnera macrophyllum</i> Siberian bugloss	12-18", clump	Blue	Spring	Part to full shade, moist, well-drained soil.	Perennial border, naturalized planting, deciduous groundcover.
<i>Caladium x hortulanum</i> fancy-leaved caladium	1-2 ft. erect plant	Leaves variously variegated with red, rose, salmon, white or green.	Not significant	Full sun to part shade, organic, well-drained soil. Needs abundant water.	Specimen plant, container, mass planting for shaded borders. Tender tuber usually needs to be dug in the fall and stored dry for winter.
<i>Convallaria majalis</i> Lily-of-the-valley	6-12 in. creeping	White, fragrant	Mid spring	Full or part shade, tolerant of most soils.	Groundcover, cut flower. Needs room to spread.
<i>Epimedium</i> spp. Epimedium, barrenwort	6-12 in. tall, 12 in. wide mounding habit	Crimson, pink, dark pink, yellow, white, rose to lilac	Mid spring	Part to full shade in moist soil.	Rock garden, perennial border, groundcover.
<i>Galium odoratum</i> sweet woodruff	4-6 in., ground-cover with erect stems	White, fragrant	Late spring	Part to full shade; moist, well-drained soil.	Rock garden, naturalized, ground cover.
<i>Helleborus</i> spp. hellebores, Lenten rose (<i>H. x orientalis</i>), Christmas rose (<i>H. nigra</i>)	12-18 in. tall and wide; evergreen foliage	White, pink, spotted, plum	Late winter to spring	Part shade, high organic, well-drained soil; neutral to slightly alkaline.	Border, cut, hummingbirds/bees; unpalatable to deer, rabbits, gophers and moles; poisonous.
<i>Heuchera sanguinea</i> bees; native; coral bells, alum root x <i>Heucherella</i>	12-20 in. tall, 12 in. wide spreading, red clump forming ground cover	White, pink, red	White, pink, early summer White, pink, early summer	Late spring to well-drained soil. Mid spring to well-drained soil.	Part shade, Border, cut, hummingbirds/ known for colorful leaves. Part shade, Border, ground cover.

Table 6.3. A Partial List of Perennial Flowers for Oklahoma (cont'd)

<i>Botanical and Common Name</i>	<i>Habit</i>	<i>Flower/ foliage colors</i>	<i>Bloom Time</i>	<i>Culture</i>	<i>Comments</i>
<i>Hosta</i> spp. plantain lily, hosta	1 ½-2 ½ ft. mound	White, lavender, to violet	Late summer	Full to part shade; organic, well-drained soil.	Border, rock garden, pools, mass plantings.
<i>Lamium maculatum</i> spotted deadnettle	Wide spreading clump 8-12 in. tall	Mauve-pink, pink, white	Late spring to midsummer	Part to full shade; well-drained, moist soil.	Ground cover, edging for border.
<i>Ligularia</i> spp. ragwort	Mounded, 3-4 ft. tall	Yellowish-orange	Midsummer to early fall	Part to full shade; well-drained, moist to wet soil.	Specimen, bog garden.
<i>Liriope</i> spp. monkeygrass	8-18 in. tall	Pale violet to white, lilac purple, violet blue, violet. Leaves are green to bluish-green or variegated with cream, white or yellow.	Summer	Sun or shade. Suitable for dry, sunny areas. Leaves are evergreen; old leaves should be removed in spring to promote new growth. Can be mowed.	Groundcover. <i>L. spicata</i> creeps and is more aggressive. <i>L. muscari</i> is more clump forming and spreads slower. Excellent grass-like plant for shady areas.
<i>Lysimachia clethroides</i> gooseneck loosestrife	2-3 ft. erect plant with 2-3 ft. spread	White	Summer	Full sun in moist, well-drained soil. Tolerates part shade.	Informal border or naturalized area. Can be an aggressive spreader.
<i>Ophiopogon japonicus</i> mondgrass, dwarf lilyturf	8-15 in. tall, mounding habit	Light blue	Summer	Full sun, part shade, with moist, well-drained soil.	Edging plant and groundcover. 'Nana' is compact growing only 3 in. tall.
<i>Polygonatum biflorum</i> Solomon's Seal	2-3 ft. tall with arching stems, 2 ft. wide	Yellowish green to greenish white; bluish black fruit in fall	Late spring	Shade; cool, moist soil.	Woodland, naturalized areas, perennial border; native.

Table 6.3. A Partial List of Perennial Flowers for Oklahoma (cont'd)

<i>Botanical and Common Name</i>	<i>Habit</i>	<i>Flower/ foliage colors</i>	<i>Bloom Time</i>	<i>Culture</i>	<i>Comments</i>
<i>Pulmonaria</i> spp. Lungwort	1 ft. spreading clump, 2 ft. wide	Pink, white or blue; variegated foliage	Early to late spring	Full shade, part shade; cool, moist soil.	Front of border or as groundcover; single specimen.
<i>Stylophorum diphyllum</i> celedine poppy, wood poppy	Upright, 18 in. tall, 12 in. wide	Bright yellow	Spring	Shade; well-drained, moist soil	Woodland garden, shade perennial border (native).
<i>Tiarella cordifolia</i> foam flower	6-12 in. tall, 12-24 in. spread	White, cultivars with pink to rose. Foliage is also quite attractive.	Mid spring	Best in part to full shade.	Borders, rock garden, woodland areas.
<i>Tricyrtis hirta</i> Toad Lily	Upright, 2-3 ft. tall, 2 ft. wide	Pale lilac, pink, or red with purple spots	Late summer, fall	Shade; well-drained, moist soil.	Woodland garden, shade perennial border, deer resistant.
Sun Perennials					
<i>Achillea</i> spp. yarrow	6-36 in. low spreading to erect	Yellow, white, pink, red, cherry-red, mauve	Late spring to late summer	Sun, well-drained soil.	Border, cut, groundcover. Quite drought tolerant once established.
<i>Agastache</i> anise-hyssop, hummingbird mint	3 ft. erect	Blue, red, pink, orange, white	Late summer	Sun, moist well-drained soil.	Border; bee, hummingbird, butterfly; flowers fragrant.
<i>Allium</i> spp. ornamental onion	3-4 ft., erect	Lilac, purple, white, or pink	Spring to early summer	Sun, well-drained soil.	Cut, border, specimen.
<i>Amorpha canescens</i> lead plant	3-4 ft. shrub	Purple with orange-tipped stamens	May-July	Sun, any soil.	Border; native garden (true prairie plant).
<i>Amsonia</i> spp. blue star (<i>A. hubrichtii</i> Thread-leaf or Hubricht's Blue Star)	3 ft. upright spreading	Blue	Spring	Sun, moist well-drained soil.	Border; native garden. <i>A. hubrichtii</i> has spectacular golden foliage in fall.

Table 6.3. A Partial List of Perennial Flowers for Oklahoma (cont'd)

<i>Botanical and Common Name</i>	<i>Habit</i>	<i>Flower/ foliage colors</i>	<i>Bloom Time</i>	<i>Culture</i>	<i>Comments</i>
<i>Armeria maritima</i> sea pink, sea thrift	Rounded mat 3-4 in. tall with flower scapes up to 12 in.	White or pink	Spring	Full sun; dry, infertile soil.	Planters, edging, rock garden, cut.
<i>Artemisia</i> spp. wormwood	1-4 ft. rounded	Not showy; silver-white foliage		Sun, dry well-drained soil.	Cut, bed, border.
<i>Asclepias tuberosa</i> butterfly weed	18-36 in. tall	Orange	Late spring to mid summer	Sun, dry infertile soil.	Border, meadow, cut, butterfly.
<i>Aster</i> spp. aster	1 – 5 ft.	Lavender , purple, red, white, pink and many shades in between	Late summer to fall	Sun, well-drained soil, average fertility. Can spread rapidly. Many cultivars.	Depends on height, naturalized areas.
<i>Aurinia saxatilis</i> basket of gold alyssum	9-12 in. prostrate habit, 18 in. wide	Yellow	Early to mid spring	Sun, tolerates dry, porous soil.	Rock garden, border, edge of wall.
<i>Baptisia australis</i> false indigo (<i>B. sphaerocarpa</i>) Golden false indigo (<i>B. sphaerocarpa</i>)	3-4 ft. erect, 4 ft. wide	Indigo-blue, white, yellow	Mid to late spring	Sun, part shade, well-drained soil, low fertility, drought tolerant.	Specimen, border; pods useful for dried arrangements. New cultivars are short, stocky, much branched, and floriferous.
Cactus	Varies	Yellow, pink, white, red, maroon	Varies	Sun, well-drained soil.	Rock garden, border, stone wall.
<i>Callirhoe involucrata</i> winecup, poppy mallow	6-12 in. tall, spread to 3 ft.	Deep reddish-purple	All summer	Sun, tolerates dry soils, tap root.	Border, rock garden, ground cover.
<i>Campanula</i> spp. bellflower, harebell	4 in. – 3 ft.	Blue, white, rose, violet-purple	Spring through summer	Sun to part shade, well-drained soil.	Edging, borders, rock gardens, naturalized areas, cut.
<i>Canna x generalis</i> Canna	1-5 ft.	Red, yellow, orange, pink white, variegated or speckled	Mid to late summer	Full sun; growth enhanced by fertilizing	Containers, background plant, perennial borders, accent plant.

Table 6.3. A Partial List of Perennial Flowers for Oklahoma (cont'd)

<i>Botanical and Common Name</i>	<i>Habit</i>	<i>Flower/ foliage colors</i>	<i>Bloom Time</i>	<i>Culture</i>	<i>Comments</i>
<i>Caryopteris x clandonensis</i> blue-mist, bluebeard	3-4 ft. high and wide	Blue	Late summer to fall	once a month. Well-drained soil, but tolerant of most soils. Full sun. Prune late winter, early spring.	Borders, specimen. Cut flower. Fragrant flowers attract birds, bees, and butterflies.
<i>Centranthus ruber</i>	Bushy to 3 ft. tall and 2 ft. wide	Pink, reddish or white fragrant.	Late spring to early summer	Full sun in well-drained, neutral to slightly acidic soil.	Border or naturalized areas. Vigorous red valerian spreader.
<i>Ceratostigma plumbaginoides</i> plumbago, leadwort	8-12 in. tall, 12-18 in. wide	Dark blue	Summer to late fall	Part shade or full sun, well-drained.	Ground cover, rock garden.
<i>Chelone lyonii</i> Pink Turtlehead	3 ft. tall, 2 ft. wide	Pink; also white and rose flowering species	Late summer to early fall	Part shade or full sun, consistently moist to wet.	Along stream or pond, border, or wild garden.
<i>Coreopsis verticillata</i> threadleaf coreopsis, whorled tickseed	2-3 ft., dense, erect clump, 2 ft. wide	Bright to clear yellow	Late spring to early summer	Sun, dry; drought resistant.	Border, naturalized area, wildflower garden.
<i>Crocosmia x crocosmiiflora</i> crocosmia, montbretia	1-3 ft. erect plant	Yellow, orange to orange-red	Mid to late summer	Full sun, moist, well-drained soil.	Border, container, cut, hummingbird plant.
<i>Delosperma nubigenum</i> hardy ice plant	1 in. high spreading 3 ft.	Yellow, purple (<i>D. cooperi</i> – purple)	Spring	Sun, needs well-drained soil; tolerates light, sandy soils.	Groundcover, rock garden.
<i>Dendranthema x morifolium</i> hardy Chrysanthemum	Mounded 1-3 ft.	Orange, yellow, red, bronze, white, lavender	Late summer to frost	Sun, well-drained soil; heavy feeder.	Border, massing, cut
<i>Echinacea purpurea</i> purple coneflower	2-4 ft. erect, 2 ft. wide	Purple, pink, yellow, orange, white	Summer	Sun, light shade; well-drained soil, drought resistant.	Border, cut, naturalized area.

Table 6.3. A Partial List of Perennial Flowers for Oklahoma (cont'd)

<i>Botanical and Common Name</i>	<i>Habit</i>	<i>Flower/ foliage colors</i>	<i>Bloom Time</i>	<i>Culture</i>	<i>Comments</i>
<i>Eryngium</i> spp. <i>E. yuccifolium</i> , Sea holly	1-3 ft. tall, depending on species	Blue	Midsummer	Full sun in sandy, dry areas.	Xeriscape plant, specimen. rattlesnake master, has greenish-white and yucca-like foliage.
<i>Euphorbia</i> spp. euphorbia, spurge	6 in.- 3 ft.	Yellow to chartreuse, orange-red	Spring to early summer	Sun to partial shade; moist or dry.	Border, rock garden.
<i>Gaillardia x grandiflora</i> blanket flower, Indian blanket	2-3 ft.	Red, yellow, combinations	Summer	Sun, light, well-drained soil.	Cut, border.
<i>Gaura lindheimeri</i> Gaura, whirling butterflies	Vase shaped to 5 ft.	Pink, white	Early summer to frost	Sun, well-drained soil; tap root, drought tolerant.	Border. Siskiyou Pink is OK Proven selection with loose growth habit.
<i>Geranium sanguineum</i> cranesbill, bloodred geranium	6-12 in., spread 24 in.	Magenta, pink, white	Late spring to early summer	Part shade, moist soil; will tolerate full sun.	Border, rock garden, ground cover.
<i>Helianthus angustifolius</i> Swamp or Narrow-leaf Sunflower	6-8 ft. tall	Golden yellow	Fall	Native to low, wet areas. Full sun.	Beds and borders. Attracts birds and butterflies.
<i>Heliotropium amplexicaule</i> Hardy Heliotrope	12 in. tall, 2-3 ft. wide	Violet with yellow centers	Spring to fall	Full sun or part shade.	Drought tolerant groundcover.
<i>Hibiscus coccineus</i> Scarlet Rose Mallow, Star Hibiscus	5-8 ft tall and wide	Scarlet. White and pink cultivars	Mid to late summer	Full sun to light shade; wet land such as swamps and marshes. Tolerant of drier soils.	Native plant. Border or accent plant, also bog garden or on edge of pond or stream.
<i>Hibiscus moscheutos</i> Rose Mallow, Hibiscus	3-8 ft. tall	Red, pink, white and bicolors	Midsummer to frost	Full sun or part shade. Tolerates moist conditions.	May naturalize in wet areas. Specimen, borders, temporary screens, along pond or lakes.
<i>Iberis sempervirens</i> candytuft	6-12 in. tall, 24 in. spread	White	Spring	Sun, well-drained soil.	Rock gardens, edging, evergreen foliage; cut back after flowering.

Table 6.3. A Partial List of Perennial Flowers for Oklahoma (cont'd)

<i>Botanical and Common Name</i>	<i>Habit</i>	<i>Flower/ foliage colors</i>	<i>Bloom Time</i>	<i>Culture</i>	<i>Comments</i>
<i>Linum perenne</i> blue flax	24 in., upright with arching stems	Sky blue and summer	Late spring	Sun, light well-drained soil.	Borders, rock garden, wildflower.
<i>Lysimachia nummularia</i> creeping jenny, moneywort	2-4 in., spreading	Yellow	Late spring	Sun or shade; moist soil.	Rock garden, groundcover, edging.
<i>Monarda didyma</i> beebealm, bergamot	2-4 ft. tall, 3 ft. wide	Scarlet, purple, pink, violet, white	Summer	Sun, part shade, well-drained moist soil; not drought tolerant.	Border, naturalized area, bees/hummingbirds. Choose mildew resistant varieties.
<i>Narcissus</i> spp. daffodil, narcissus	6-24 in., erect	White, yellow, orange, orange-red, pink shades	Spring	Sun, part shade, well-drained soil.	Naturalized area, border.
<i>Oenothera speciosa</i> Showy Evening primrose	6-24 in. tall, 18 in. wide	White to pinkish	Summer	Infertile, well-drained soil in full sun.	Native plant. Raised beds and rock gardens. <i>O. missouriensis</i> has yellow flowers.
<i>Paeonia</i> hybrids peony, (<i>P. suffruticosa</i>) tree peony	3 ft., round habit	Various	Late spring to early summer	Sun, light shade; well-drained, deep fertile soil.	Specimen in border, cut.
<i>Penstemon barbatus</i> penstemon, beardtongue	18-36 in., round	Scarlet pink, pink, orange, white	Late spring to mid summer	Sun, tolerates dry, prefers moist soil.	Naturalizing, border, cut. Quite drought tolerant once established. Indigenous species to Oklahoma – <i>P. oklahomensis</i> .
<i>Perovskia atriplicifolia</i> Russian sage	3-4 ft., upright	Lavender-blue	Summer	Sun, well-drained soil.	Background, border.
<i>Phlox paniculata</i> garden phlox	2-4 ft.	White, pink, red, blue, and purple	Summer and early fall	Full sun to part shade in fertile, moist soil.	Border. Plant powdery mildew resistant varieties.
<i>Phlox subulata</i> creeping phlox	3-6 in. tall, 2 ft. wide	Red-purple to violet-purple, pink or white	Early to mid-spring	Sun, well-drained, slightly alkaline.	Groundcover, edging.
<i>Rubus calycinooides</i> creeping raspberry	6-12 in. high, 5 ft. wide, evergreen groundcover	White. Attractive orangish-red fruit.	Early summer	Sun to part shade. Tolerant of most soil conditions.	Winter leaf color is burgundy. Attracts birds, butterflies and bees.

Table 6.3. A Partial List of Perennial Flowers for Oklahoma (cont'd)

<i>Botanical and Common Name</i>	<i>Habit</i>	<i>Flower/ foliage colors</i>	<i>Bloom Time</i>	<i>Culture</i>	<i>Comments</i>
<i>Rudbeckia grandiflora</i> large coneflower	2-3 ft.	Yellow with brown cones	Early to mid summer	Sun, prefers well-drained, dry soil.	Border, wildflower/native.
<i>Rudbeckia hirta</i> var. <i>pulcherrima</i> black-eyed-Susan	2-3 ft., erect to round	Golden yellow, orange, bronze; brown to black disk	Summer and fall	Full, light shade, hot, dry.	Cut, background, border, bed.
<i>Rudbeckia maxima</i> giant coneflower	5-6 ft.	Bluish-green leaves. Large yellow flowers with large black cones	Early to mid summer	Prefers full sun with moist, well-drained soil.	Specimen, border, native planting.
<i>Ruellia brittoniana</i> Mexican petunia, ruellia	6 in. to 36 ft. depending on species and cultivar	Blue, purple, pink, white	Summer to fall	Thrives in dry or soggy soils.	Compact cultivars good for border or edging. Taller species good for background. Several other species available.
<i>Salvia greggii</i> autumn sage	2-3 ft., semi-shrub	Pink, red, white	Early summer to frost	Sun, prefers well-drained, dry soil. Very drought tolerant	Border, container; hummingbird plant.
<i>Salvia guaranitica</i> Anise-scented sage, 'Black & Blue'	2-5 ft. tall and wide	Deep blue with purple-blue calyx	Summer through fall	Full sun, part shade.	Attracts butterflies, deer resistant. Calyx of 'Black & Blue' is dark purple appearing black.
<i>Saponaria</i> spp. Soapwort, Bouncing Bet	4-10 in. trailing habit	Deep pink, rose, white	Late spring, sporadic through fall	Full sun, well-drained soil.	Rock gardens, tone walls, groundcover.
<i>Sedum</i> spp. sedum	2-24 in., forming to erect growth habit	matPink, red, scarlet, yellow, white	Summer to fall	Sun or light shade, any soil well-drained.	Ground cover, rock garden, border.
<i>Silphium perfoliatum</i> Cup Plant, Rosin Cup Plant	3-8 ft.	Yellow	Mid to late summer	Sun, prefers moist, rich soil.	Wildflower/native plant gardens, naturalized and open woodland areas, pond and stream edges.
<i>Stachys byzantina</i> lamb's ear	12-15 in., spreading	Purplish pink	Summer	Sun, well-drained soil	Groundcover, edging, border.

Table 6.3. A Partial List of Perennial Flowers for Oklahoma (cont'd)

<i>Botanical and Common Name</i>	<i>Habit</i>	<i>Flower/ foliage colors</i>	<i>Bloom Time</i>	<i>Culture</i>	<i>Comments</i>
<i>Thymus</i> spp. slopes, Thyme	½ in. to 12 in. tall and 12-18 in. wide depending on species and cultivar	pink	Purple, lilac,	Spring loose, well- drained soil.	Full sun in a Containers, beds & borders, groundcover, rock garden. Some species have herbal and culinary properties.
<i>Verbena canadensis</i> 'Homestead' Homestead verberna	6 in., low spreading	Deep purple	Summer to frost	Sun, well- drained soil.	Groundcover, edging, rock garden, border.
<i>Veronica</i> spp. speedwell, <i>V. prostrata</i> - creeping veronica;					
<i>V. spicata</i> spike speedwell	8-18 in. tall	Blue, lavender, pink, white, rose-pink, purple	Late spring to mid summer	Sun or partial shade, well- drained soil.	Border, groundcover (<i>V. prostrata</i>), naturalized planting, rock garden.

Commonly Grown Bulbs Suitable for Oklahoma

(Taken from material prepared by Albert Sutherland, CPH, CCA)

Below is a list of perennial bulbs adapted to Oklahoma and their flower size, flower color, bloom time, planting depth and bulb spacing. All bulb planting depths are the distance from the top of the bulb; plant in October unless otherwise noted. Before planting, mix 3 inches of a well-composted organic material into the top 9 to 12 inches of soil and water on a regular basis.

Astroemeria ligtu (Peruvian lily): 2-inch white to pink, salmon, peach or orange flowers on 3- to 4-foot tall stems in May-June. Plant 8 inches deep and 1 foot apart where afternoon shade occurs. Great cut flower.

Allium giganteum (Giant allium): 5- to 6-inch wide round purple flower on a 3- to 6-foot tall stem in May-June. Plant 6 inches deep and 1 foot apart in full sun or light shade.

Allium sphaerocephalum (Giant allium): 3-inch wide round lavender flower on a 1- to 2-foot tall stem in June. Plant 4 inches deep and 6 to 9 inches apart in light shade. Multiple stems from one bulb, like chives.

Anemone coronaria (Poppy anemone): 2-inch wide white, red, blue or purple flowers on 5- to 10-inch stems in May to June. Plant 3 inches deep and 4 to 6 inches apart in light shade.

Anemone nemorosa (Wood anemone): 1-inch white, pink, blue or lavender flowers on 6- to 8-inch stems in March. Plant 3 inches deep and 4 to 6 inches apart in light shade or full sun.

Belamcanda chinensis (Blackberry lily or leopard flower): 2-inch wide orange blooms with reddish specks on 3- to 4-foot flower stalks in June. Blackberry like seed pods in the fall. Plant 2 inches deep and 6 inches apart in full sun.

Colchicum sp. (Autumn crocus): 2- to 8-inch wide star-shaped flowers of purple, lavender, pink or white borne on 4- to 8-inch tall stalks in September to October. Plant 4 inches deep 6 to 9 inches apart in full sun or light shade.

Convallaria majalis (Lily-of-the-Valley): Delicate bell-like flowers on 1-foot-tall plants with wide green leaves. Plant 3 inches deep and 4 to 6 inches apart in afternoon shade.

Crocus sp. (Crocus): 1-inch wide orange, yellow, gold, white-blue, purple, lavender or bicolor flowers borne on 2- to 4 -inch tall stalks in February-March. Plant 4 inches deep 2 to 3 inches apart in full sun or light shade. Lots of different species.

Fritillaria imperialis (Crown imperial): Large red, yellow, or orange flowers borne in a whorl atop 2- to 3-foot stems in April-May. Plant 7 inches deep and 6 inches apart in a location with afternoon shade.

Fritillaria melagris (Checkered lily): Delicate white flowers are checkered with varying colors from deep brown to lilac or deep purple and hang daintily on a 10-inch tall stem in April to May. Plant 7 inches deep and 6 inches apart in a location with afternoon shade.

Galanthus (Snowdrop): White 1-inch wide butterfly-like flowers on 1-foot tall plants in February to March. Plant 4 inches deep and 3 inches apart in light shade. Plant in large numbers and do not disturb.

Hyacinthus orientalis (Garden hyacinth): Clusters of purple or white blooms on a 6- to 9-inch stalk in March to April. Plant 5 inches deep and 6 to 8 inches apart in full sun or light shade.

Lilium sp. (Lily): Wide group of bulbs that includes plants in eight divisions, the most popular and easiest to find are:

1) Asiatic hybrids, Division #1: 4- to 6-inch wide red, pink, orange, yellow, lavender or white flowers on a 4- to 6-inch stalk in June to July. Plant 7 inches deep and 1 foot apart in full sun or light shade.

2) Oriental hybrids, Division #7: Up to 12-inch wide deep red, pink, white or bicolor flowers on 2- to 8-foot stalks in June to July. Plant 7 inches deep and 1 foot apart in full sun or light shade.

Lycoris radiata (Spider lily): Many crimson-red blooms on a 12-inch stem in September. Plant 3 inches deep and 6 inches apart in full sun. Plant bulbs in August before flower stems appear.

Lycoris squamigera (Magic lily or Resurrection lily): Cluster of rose-pink blooms on a 1.5- to 2-foot stem in August. Plant 3 inches deep and 6 inches apart in full sun. Easily confused with *Amaryllis belladonna*, which is not winter hardy in Oklahoma.

Muscari armeniacum (Grape hyacinth): Cluster of blue, lavender, white or white and blue flow-

ers on a 9-inch stem in March. Plant 3 inches deep and 1 to 4 inches apart in full sun or light shade.

Muscari botryoides (Common Grape hyacinth): Cluster of white flowers on a 12-inch stem in March. Plant 5 inches deep 1 to 4 inches apart in full sun or light shade.

Narcissus sp. (Daffodil, Narcissus or Jonquil): Contains 12 divisions and many species. Colors can be white, yellow, gold, orange, pink, red or bicolored in single or double trumpet-like blooms that appear in February to March. Plant 4 inches deep and 4 to 6 inches apart in full sun or light shade.

Scilla campanulata, also *Hyacinthoides hispanica* (Wood hyacinth or squill): Blue, purple, lavender or white flowers on a 12-inch stem in May. Plant 4 inches deep and 3 to 4 inches apart in full sun or partial shade. Can be invasive, so use to fill in wilder areas.

Scilla siberica (Siberian squill): Deep blue flowers on a 6-inch stem in February-March. Plant 4 inches deep and 3 to 4 inches apart in full sun or partial shade. 'Alba' is a white cultivar of *Scilla siberica*. *Scilla tubergeniana*, also *Scilla mischtschenkoana*: White flowers with a brilliant blue midrib on a 6-inch stem in February to March. Plant 4 inches deep and 3 to 4 inches apart in full sun or partial shade.

Tulipa sp. (Tulip): The king and queen of all the bulbs. Eleven groups are recognized by Dutch experts. The variety of color and flower form is too numerous to present here. Plant 6 inches deep and 3 to 6 inches apart in a location with afternoon shade. Plant in November. Bloom size and quantity decrease each year, prompting many folks to replant on a regular basis.

Table 6.4. Perennial Ornamental Grasses.

<i>Botanical and Common Name</i>	<i>Height (feet)</i>	<i>Light</i>	<i>Foliage</i>	<i>Flower</i>
<i>Arundo donax</i> Giant reed grass	14	Sun	Gray-green	White
<i>Arundo donax</i> 'Variegata' Variegated giant reed grass	10	Sun	Green/Cream	White
<i>Bouteloua gracilis</i> Blue grama grass	2	Sun	Green	White
<i>Calamagrostis acutiflora</i> 'Stricta' Feather reed grass	4	Sun-Lt. Shade	Green	Pink to beige
<i>Calamagrostis x acutiflora</i> 'Karl Foerster' Foerster's feather reed grass	3-4	Sun-Lt. Shade	Green	Pink to beige
<i>Calamagrostis arundinacea</i> var. <i>brachytricha</i> Foxtail grass, fall blooming reed grass	3	Sun	Green	White
<i>Erianthus ravennae</i> Ravenna grass, hardy pampas grass	12-14	Sun	Gray-green	White
<i>Festuca cinerea</i> cultivars	0.7	Sun	Blue-gray	None
<i>Hakonechloa macra</i> 'Aureola' Golden variegated hakone grass	1	Part shade	Yellow/Green; Pink-red in fall	None
<i>Koeleria pyramidata</i> Hairgrass	1.5	Sun	Green	Amber
<i>Miscanthus giganteus</i> (<i>M. floridulus</i>) Giant Miscanthus	10	Sun-Lt. Shade	Green/White	None
<i>Miscanthus sinensis</i> 'Adagio'	5-6	Sun	Green/White	White
<i>Miscanthus sinensis</i> 'Cosmopolitan' Variegated Miscanthus	5-6	Sun	Green/White	Beige
<i>Miscanthus sinensis</i> 'Gracillimus' Maiden grass	5	Sun	Green/White	Copper
<i>Miscanthus sinensis</i> 'Graziella' Slender Miscanthus	3-4	Sun	Green	White
<i>Miscanthus sinensis</i> 'Malepartus'	5-6	Sun	Green/White	White
<i>Miscanthus sinensis</i> 'Morning Light' Slender variegated Miscanthus	5-6	Sun	Green/White	Copper
<i>Miscanthus sinensis</i> 'Yaku Jima' Dwarf Miscanthus	4-5	Sun	Green	Amber
<i>Miscanthus sinensis</i> <i>condensatus</i> 'Silberpfeil' Silverarrow grass	5-7	Sun	Green	Gold
<i>Miscanthus sinensis</i> 'Purpurascens' Flame grass	4.5	Sun	Green	Purple
<i>Miscanthus sinensis</i> var. <i>strictus</i> Porcupine grass	5	Sun	Green/Yellow	Copper/Beige
<i>Miscanthus sinensis</i> 'Zebrinus' Zebra grass	5	Sun	Green/Yellow	Copper/Beige
<i>Molinia caerulea</i> subsp. <i>arundinacea</i> 'Windspiel' Windplay tall moor grass	6-7	Sun-Lt. Shade	Green	Yellow

Table 6.4. Perennial Ornamental Grasses (cont'd).

<i>Botanical and Common Name</i>	<i>Height (feet)</i>	<i>Light</i>	<i>Foliage</i>	<i>Flower</i>
<i>Panicum virgatum</i> Switch grass	4-6	Sun	Green	White
<i>Panicum virgatum</i> 'Haense Herms' Red switch grass	4-6	Sun	Red/Green	White
<i>Pennisetum alopecuroides</i> Fountain grass	3	Sun-Lt. Shade	Green	Reddish cast
<i>Pennisetum alopecuroides</i> 'Moudry' Black-seeded fountain grass	3	Sun-Lt. Shade	Green	Smoke black
<i>Pennisetum orientale</i> Oriental fountain grass	3	Sun	Red	Copper
<i>Phalaris arundinacea</i> var. <i>picta</i> Ribbon grass	2.5	Sun	White/Green	None
<i>Schizachyrium scoparium</i> Little bluestem	2-4	Sun	blueish tint	purple-bronze
<i>Spartina pectinata</i> 'Aureomarginata' Golden-edged prairie cord grass	2.5	Sun-Lt. Shade	Green/Yellow	None
<i>Stipa tenuissima</i> Mexican feather grass	1.5, clump	Sun	Green	Beige to light green
Annual Ornamental grasses:				
<i>Agrostis nebulosa</i> Cloud grass	1.5	Sun	Green	White
<i>Briza maxima</i> Large quaking grass	1.5	Sun	Green	Oat-like
<i>Melinis nerviglumis</i> 'Savannah' Pink Crystals Ruby Grass	1.5-2	Sun	Blue-green	Ruby-Pink
<i>Pennisetum setaceum</i> Pink fountain grass	3	Sun	Green	Pink
<i>Pennisetum setaceum</i> 'Atrosanguineum' (<i>P. setaceum</i> 'Cupreum')	3	Sun	Maroon	Red-purple
<i>Pennisetum villosum</i> Feathertop	2	Sun	Green	White
Sedges (semi-evergreen):				
<i>Carex morrowii</i> 'Variegata' Silver variegated Japanese sedge	1	Part to full shade	Green/White	None
<i>Carex ornithopoda</i> 'Variegata' Variegated Bird's foot sedge	0.5	Part to full shade	Cream/Green	None
<i>Carex stricta</i> 'Bowles Golden' Bowles golden grass	1.5	Full shade	Yellow	None

ORNAMENTALS PART 3

Woody Landscape Plants

Learning Objectives:

After completing this section, Master Gardener trainees will be able to:

- Know what criteria should be considered when selecting woody ornamental plants for a particular site.
- Understand and be able to apply good planting techniques for woody ornamental plants and understand how using proper techniques can improve survival and accelerate establishment.
- Be able to describe proper follow-up care after woody ornamental plants are installed in the landscape.
- Be able to describe the proper timing, procedures and techniques used in pruning deciduous and evergreen woody ornamental plants.
- Understand the reasons for fertilizing woody ornamental plants and describe the various methods of fertilizer application.
- Know the options for weed management in landscape plantings.
- Be familiar with major problems of woody ornamental plants.

Woody Landscape Plants

Woody ornamental plants are key components in a well-designed, useful landscape. This large group of plants can be divided into four general categories — trees, shrubs, groundcovers and vines. These categories are defined as follows:

Trees — Woody plants that produce one main trunk and a more or less distinct and elevated head (height of 15 feet or more).

Shrubs — Woody plants that remain quite low and usually produce multiple shoots or stems from the base (height of 15 feet or less).

Vines — Climbing or crawling woody plants without self-supporting upright stems.

Groundcovers — Very low growing, spreading, shrubs and vines.

This section will cover factors to consider in selecting plants based on desired uses. Environmental factors influencing plant growth and procedures for planting and caring for woody plants are also discussed. A listing of vines, groundcovers, shrubs and trees recommended for use in Oklahoma is provided at the end of this section.

Plant Selection

Vines

Vines are climbing plants that add interest to the landscape. Vines easily lend themselves for use in a large landscape setting as well as the patio garden. They serve many purposes, ranging from screening to shade, as well as serving as architectural accent plants. Vines are useful as groundcovers, forming a cascade of bloom on rough, steep banks while holding the soil in place. Vines also work well as groundcovers in shady areas to replace turf in an attempt to reduce irrigation and maintenance needs. The flexibility of vines in the home landscape is probably the main reason they are enjoying a resurgence in popularity.

Selection - Vines have the ability to grow toward the light they need. They can “climb” many different items for support and can be trained to grow on walls, fences, arbors, trellises, posts and even other plants. When searching for a vine, determine the sturdiness of the structure to be used, and plan accordingly for a vine that will not outgrow the structure and pull it down.

Vines use many different methods to climb. It is important to know how a particular vine attach-

es itself to its support to provide it with the proper tools for climbing. Some vines can attach to walls without support and others need trellises or wire to enable them to climb. There are five basic methods plants use to climb.

The first group uses aerial roots or “holdfasts” to attach itself to a structure. The aerial roots take hold of a roughened surface such as brick, stone or wood. These plants don’t need additional help to climb; however, they do require a roughened surface. Plants in this group include English ivy and climbing hydrangea.

The second group of plants climbs by using saucer-like appendages that exude an adhesive resin that firmly attaches to a surface. These plants will also climb unaided, and in addition to roughened surfaces, they can also climb smooth surfaces. Plants in this group include Virginia creeper and Boston ivy.

The third group climbs by using tendrils. Tendrils are modified stems that twist about any nearby support. These plants require something small enough for the tendril to wrap around such as a cord, some type of trellis or other plants. Grapes are an example of plants that use this method to climb. There are also several modifications of tendrils such as the leaf tip or leaf stalk acting as a tendril as in the case of Clematis.

The fourth way vines climb is by twining. As the young shoots elongate, they make a rotary motion and encircle a small support such as a wire, twig or other object small enough for them to encircle. They cannot sweep around a large pole or tree but can easily encircle a wire or a cord. Some of these plants twine clockwise and some twine counter-clockwise when viewed from the top. This is handy to know if you desire to help the vine along by twisting it around its support. Study the direction it wraps and wrap the new growth in the same direction. If you wrap it in the opposite direction, it will unwrap itself and start over in the direction it is naturally growing.

The final group of plants aren’t really considered vines, rather they are shrubs with elongated, arching stems. They are known as ramblers. Many contain thorns or prickles that will catch on nearby plants or other supports enabling the plant to climb. Plants in this category include Climbing Roses. These plants benefit from some help in climbing by tying or otherwise attaching the branches to a fence, arbor or other support for the best effect.

Culture – Most vines will quickly revert to a tangled mass of foliage on the ground if not given the proper means of support and a reasonable amount of care and maintenance. The best type of support for vines gives the required structural strength and stability, and at the same time, is neat in appearance.

Like most other plants, vines require some maintenance. Pruning is necessary to remove old wood. This may require several cuts to each stem so they can be untangled. It often is necessary to prune occasionally to keep the plant within bounds and to guide future growth. As with other plants, vines are pruned to produce better bloom. Insect and disease control is important. This involves regular visual inspection for pest damage, and if necessary, use of environmentally sound control methods.

The area to be covered should be studied carefully to determine what type of vine should be used. Rate of growth is a critical consideration, since there are vines that exhibit rampant growth and can soon become a nuisance.

Groundcovers

In a broad sense, groundcovers include any material covering the ground surface so the ground cannot be seen from above and rain does not strike directly upon the soil. With this definition, grass, various types of paving, shrubs and even trees could be called groundcovers. However, for this section, groundcovers are referred to as low-growing (up to 18 inches), mat-forming or trailing plants, other than grasses or other plants that tolerate walking or mowing. Most ground covers are not intended to be walked upon and will be severely damaged by pedestrian traffic.

When groundcovers are chosen carefully and placed correctly, they greatly enhance the beauty of the landscape composition. In addition to their aesthetic value, they fulfill a number of other important functions including the following:

- Control erosion on slopes.
- Obstruct traffic without impeding view.
- Conserve soil moisture and lower temperatures during periods of extreme heat.
- Reduce lawn maintenance.
- Fill narrow, odd-shaped areas where mowing and edging might be difficult.
- Provide vegetative growth where grass is difficult to maintain.

- Produce interesting patterns with variation in height, texture and color.

In practice, the groundcovers most frequently used are plants that are easily propagated, vigorous and hardy perennials.

Selection – Selection of a groundcover will depend upon the area where it will be used. Is the area flat or sloping? Is it sun, or partially or deeply shaded? Soil conditions must be studied. Some groundcovers prefer a moist soil, rich in organic matter, while others will adapt to a dry, sandy situation. Give consideration to color, texture, height and habit as well, since some groundcovers tend to grow rampantly. One problem that may limit the use of groundcovers is the cost of installation since large numbers of small, individual plants are required. In addition, a well-prepared planting bed is essential to the establishment of groundcovers and can be costly and time-consuming. Weed control in a newly planted groundcover bed can likewise be difficult and labor-intensive.

Culture – Significant maintenance is necessary for the first one to three years or until the groundcover becomes established. Cultivation is necessary to control weeds and other plant invaders; fertilization to encourage fast, vigorous growth to achieve good cover; irrigation in time of dryness; and disease and pest control. When these maintenance considerations are ignored, the progress toward achieving a good ground cover planting is disappointing.

Wherever paving, lawn or cultivated beds are not desirable, groundcovers can be successfully used. Newly cut banks and any slopes greater than 12 percent are best treated with groundcover plantings. Around buildings, groundcovers are superior to paving or structural controls for reducing heat, glare, noise and dust.

Trees and Shrubs

Because there are so many woody plants for use in landscaping, carefully select plants appropriate for your needs.

Selecting Trees and Shrubs. Selection should be based on several different factors. The intended purpose should influence selection of plants with appropriate shape, size and other physical characteristics. Trees are used for shade, ornamentation, screening, windbreak and sound-reducing purposes. Shrubs are used for screens, barriers,

windbreaks, ornamentation, groundcovers and wildlife shelters. Both trees and shrubs can be selected to provide edible fruit or nuts.

Providing shade usually requires tall, sturdy, long-living species. Density of foliage, which determines the amount of shading, is important. A tree such as red maple will produce a very dense shade that prevents other plants from growing under it, while a Kentucky coffeetree will produce a light partial shade, allowing other plants enough sunlight to grow. Deciduous trees should be used to shade the south windows of a home in the summer, allowing the sun to penetrate in the winter.

Screens usually require plants that produce dense foliage. Windbreaks must be able to survive rigorous climate conditions. Evergreen plants are usually chosen for screening. Barrier plantings usually require sturdy plants with dense growth and possibly thorns or spines.

Ornamental attributes are quite varied. Both trees and shrubs can be selected for flowers, colorful fruit, interesting foliage, fall or winter color, interesting bark or interesting shapes of the plants themselves.

Consider the size of mature trees and shrubs and where they are to be used. Trees that grow tall, such as the American elm, white oak, sycamore, and tulip tree, are suitable for larger buildings and spaces. They tend to dominate or hide one-story buildings. For attractive and proper balance with one-story buildings, trees shorter than about 35 feet when full grown are recommended. Shrubs that outgrow their spaces can hide windows, block walkways or crowd out other plants. Shrubs can sometimes be kept small by pruning, but this requires continuing maintenance. Careful consideration of mature size will reduce the need for pruning.

Shape is especially important in selecting trees for ornamental and shade purposes. Tall trees with long, spreading or weeping branches give abundant shade. Small trees and trees of other shapes, including narrow, columnar, pyramidal and clump forms and the low growing types such as hawthorn, crabapple and dogwood have ornamental purposes, but do not give abundant shade.

Environmental conditions should influence the selection of plants. Size of the planting area is important, as are site characteristics such as sunny or shady, wet or dry, exposed to winter winds or pollution. Plants selected should be tolerant of ex-

isting conditions, and be hardy in the appropriate climate zone. The country is defined in a series of zones, based on the average minimum winter temperature (Figure 6.30).

Finally, consider how much maintenance the plant will require and any possible disadvantages including susceptibility to attack by disease and insect pests; soft or brittle wood that is easily damaged by wind and ice; fruits and seeds that are large, messy, smelly or otherwise obnoxious; and abundant shedding of twigs and small branches. Some examples of these conditions are killing of Lombardy poplar by *Cytospora* canker or by borers, breaking of Siberian elm branches by wind and ice and the production of bad-smelling fruit by the female ginkgo. The production of fruit by the mulberry, which attracts birds, can also be an undesirable characteristic. Since this fruit is soft and decomposes rapidly when ripe, it is messy on walks and attracts flies and other insects.

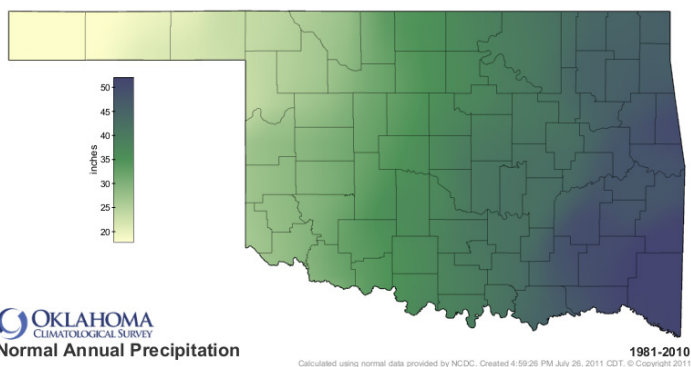
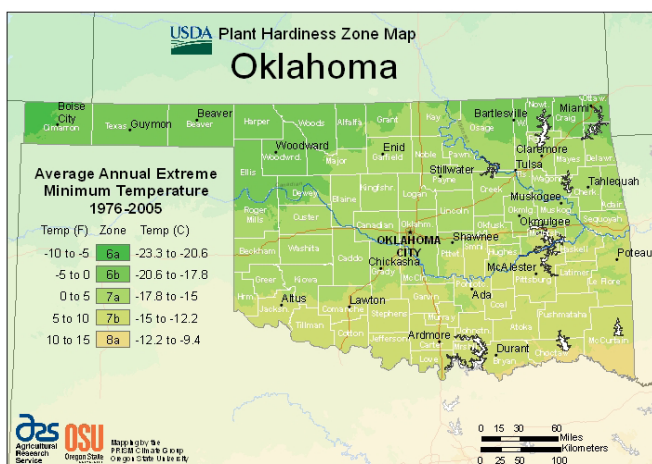

Figure 6.30. USDA Plant Hardiness Zone Map for Oklahoma and State Annual Precipitation map.

Purchasing Trees and Shrubs. Once the selection process is completed, plants can be purchased. Transplants can be classified into four classes according to the way they are dug and/or shipped: bare-root plants, balled and burlapped plants (B&B), container grown plants and tree spade dug.

Bare-Root Plants – These have had the soil washed or shaken from their roots after digging. Most mail-order plants are of this class because plants in soil are too heavy to ship economically. Plants available in nurseries in early spring with roots wrapped in damp sphagnum and packaged in cardboard or plastic containers are also bare-root plants. These need special attention because their roots are tightly bunched up in unnatural positions to force them into the package. Discard the sphagnum packing and be sure to spread the roots out to a natural position.

Plants in the bare-root class are planted while they are dormant; therefore, late winter planting is best for these plants. Never let the roots dry out; this is perhaps the single, most common cause for failure with bare-root plants. Keep roots in water or wrapped in plastic or wet paper until ready to place the plant in the hole.

Balled and Burlapped Plants – B&B plants are primarily trees and some shrubs. They are usually grown in nursery rows for some time and are root-pruned so the root system within the balls is compact and fibrous. Such plants rapidly reestablish themselves. This method is primarily used for plants that never lose their foliage and not amenable to bare-root treatment. B&B plants include broadleaf evergreens like rhododendrons and azaleas, and conifers of all types. A number of deciduous trees and shrubs that have branching root systems and easily contained in a soil ball are also sold as B&B plants. They can be planted almost anytime the ground can be worked. Plants put out in summer will need special attention to keep them adequately watered.

When selecting a balled and burlapped plant, be sure the ball is sound and hasn't been broken. Avoid those plants that feel loose in the soil balls. Be sure the soil ball does not dry out. These plants will usually need very little pruning at planting.

Container-Grown Plants – These are usually grown in the container in which they are sold and are becoming a standard in the nursery trade. Because of their appearance, many home gardeners

are often misled into thinking that all they have to do is place these plants into the ground and forget about them. However, these plants need the same careful planting and maintenance as other plants — proper watering is critical. Container-grown plants can be planted throughout the year.

Container-grown plants have the least amount of root disturbance of all forms. In Oklahoma, fall planting is best for deciduous trees, shrubs and pines, and spring planting is best for broadleaf evergreens. Inspect the roots to make sure they are not circling the top of the pot or growing heavily out of the bottom. If this is the case, choose a different plant. Circling roots can continue to circle after planting, eventually girdling the plant. If the plant does have a few circling roots in the bottom of the pot, this condition can be treated at planting by scoring the root ball to promote new root growth and break the circling habit.

When selecting plants, look for a good, natural shape free from thin spots or broken limbs. Make sure the root ball is solid and the bark has no splits or cracks. Avoid any container-grown plant where roots circling on the surface or coming out of the drainage holes are seen. Plants chosen should be free of any insects or diseases. Generally, the smaller sizes of a plant will cost less and may establish faster.

Trees Spade Dug Trees – Tree spades are large machines that cut the roots and soil around a tree. They are often used to dig balled and burlapped trees in the nursery. Tree spades are used by landscape contractors to transplant larger trees into holes previously dug with the same machine. The best time for this procedure is in the spring or fall.

Planting Trees and Shrubs

The proper installation of plants in the landscape involves much more than just digging holes and setting plants in them. The planter is responsible, as far as possible, for developing a satisfactory microclimate for optimum growth and development of the plant. A healthy and vigorous plant is required if the landscape is to achieve the desired effect. Healthy plants will need less maintenance in the years following establishment.

The planting hole is important since this is the environment of the plant root system. Plant professionals make many suggestions about how large

the planting hole should be, but generally if the hole is twice as wide in diameter and no deeper than the soil ball, the size will be adequate. In general, research shows the wider the hole is, the better the plant will grow.

A traditional recommendation for preparing a planting hole for trees and shrubs has been to incorporate organic matter into the backfill soil before returning it to the hole around the plants. However, recent research indicates this can actually be detrimental to the long-term establishment of the landscape plant. By backfilling the hole with native soil, the plant is immediately forced to establish new roots in the backfill and beyond.

Apparently, the addition of organic matter into backfill soil creates an interface between the amended soil and the undisturbed soil around the planting hole that is detrimental to root growth and water movement between the two soils. In tests conducted at the University of Georgia, examination of plant root systems in holes with amended soil revealed that the majority of the roots were confined to the original planting hole. Therefore, it is recommended to use only excavated soil as backfill.

Generally, it is best to excavate the hole no deeper than the depth of the soil ball. Place the top of the soil ball at soil level or slightly higher than the surrounding soil. The finished planting depth (after the soil settles) should be such that the plant is exactly the same depth after replanting as it was when grown in the nursery. When planting in a poorly drained site, set the plant so a few inches of the rootball are above the soil level to enhance drainage (Figure 6.31). More plants are probably lost because they were planted too deeply than for any other reason. This is especially true with large, balled and burlapped trees and shrubs, such as yaupon holly or mountain laurel, which are often top-heavy and planted deeply so they will not topple.

Once the appropriate size hole has been dug, carefully place the plant in the hole. Carefully handle B&B plants when placing in the hole. For most species, if the soil ball is broken for any reason, many of the roots will be severed from the trunk and the plant will die. Always pick the plant up by the soil ball or container, but never by the trunk or stem. Recently, some nurseries have been using woven plastic or synthetic materials to wrap B&B

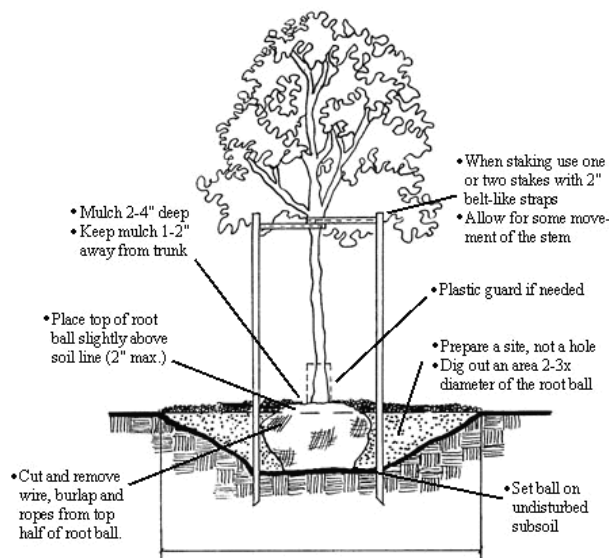

Figure 6.31. Diagram of properly planted tree.

plants. These materials do not rapidly decompose and can girdle roots as they enlarge after passing through the material. While it is not necessary to remove the burlap, always remove these plastic and synthetic materials after the plant is placed in the hole. On all B&B plants, cut and remove any strings (plastic or natural fiber) from around the trunk after planting to prevent girdling the plant.

For container-grown plants, always remove plastic or metal containers before planting. Small containers with tapered sides can be removed by turning the plant upside down and giving the top edge of the container a sharp rap. Catch the soil ball in the hands as it slips from the container. Do not let the soil ball break apart. Larger containers (5 gallons or more) should be cut away. If plants have become overgrown in the container and the root mass is growing in a tight, compact circle around the soil ball, cut the outer roots out with a sharp knife in two or four places around the soil ball. Make the cut from the top to the bottom of the soil ball. Though decomposable containers, such as paper maché, are meant to be left on at planting, it is generally best to treat it like any other container and remove it at planting to avoid the potential of inhibiting root development.

Bare-root plants should have the packing material and all damaged or dead roots removed. Do not allow roots to be exposed to sunlight or to dry out before planting. It is best to keep bare roots

covered with moist burlap or some reasonable substitute until planting time.

After the B&B or container-grown plant has been placed in the hole, fill the hole around the plant with backfill until it is two-thirds full. With bare-root plants, the soil should be worked gently in and around the roots while the plant is being supported. The most satisfactory way to firm the soil and remove air pockets is by filling the hole with water, firm the soil by hand around the plant ball or roots. However, be sure not to use excessive force since soil compaction should be avoided.

Before finishing the filling process, make certain the plant is straight and at the proper depth; then complete the filling process with the backfill. If it is an individual specimen, construct a ring of earth 2 to 3 inches high at the edge of the outside diameter of the hole to form a water basin. Plants in beds probably will not require a water basin. Water the plant thoroughly as soon as the water basin is complete. After the water has soaked away, fill the basin with mulch. Organic mulches such as pine needles, bark or wood chips provide the best environment for future root development.

Note that fertilizer is not added to the backfill. Too much fertilizer can damage newly developing roots. If soil testing indicates fertilizer is needed, add a water-soluble material at the recommended rate during the final watering phase. Large areas should already have an established fertility level based on soil test results before individual plant specimens are planted. A fertility program should begin in late fall of the first growing season.

One final activity in planting is to remove all tags and strings. These items, whether made of wire, plastic or natural fibers, can potentially girdle fast-growing stems and trunks.

Pruning and supporting

An initial pruning may be needed immediately after planting; however, this pruning should be directed only at the removal of all broken and damaged branches. The traditional practice of removing part of the top growth to reduce transpiration and to bring the top back in proportion to the root system (for example, bare-root trees) is no longer recommended. For better success of newly planted woody species, avoid heavy pruning at planting. Ensure the plants will be well watered during the first year or two in the ground. Pruning reduc-

es the leaf area, thus reducing transpiration, but it also reduces the leaf surface area, which produces photosynthates for root growth. Since the plant will not resume a normal growth rate until the original root system size is re-established, it is better to avoid wilting by watering than by canopy pruning. This also avoids a proliferation of suckers in the inner canopy.

Most shrubs do not need to be supported after planting, unless the bare-root stock planted is quite large or very tall B&B specimens have been used. If so, use the same techniques for shrubs as described for trees.

A general rule is to provide support for all bare-root trees more than 8 feet in height. Smaller B&B or container-grown trees usually do not need support. Trees 6 inches or more in diameter should be supported. Any one of several methods for supporting smaller trees is satisfactory.

1. A single stake about $\frac{3}{4}$ the height of the bare-root tree should be driven at a distance of 2 to 4 inches from the center of the planting hole on the southwest side. This should be done before the tree is placed into the hole. Plant the tree according to the procedures described previously. After the planting, fasten the tree to the stake with a strap and grommet type system formed in a loose loop (Figure 6.35). The advantage of this method of support is that the stake is close to the trunk and does not cause maintenance problems. In turf areas, stakes and guy wires outside the perimeter of the mulched area can be troublesome, since they hinder mowing operations. Under no circumstances should this method of support be used on B&B or container-grown stock. It is usually not possible to locate a stake close to the trunks of such stock before planting, and if driven through the soil ball, the stake will cause damage to the soil ball and roots.
2. A more satisfactory method of supporting small trees is to use two parallel stakes driven solidly at least 18 inches into the firm soil about a foot beyond the planting hole on opposite sides of the tree (Figure 6.32). The height of the stakes after being driven into the ground should be approximately $\frac{2}{3}$ that of the tree. The tree is then supported by straps looped loosely around the trunk and wires attached to straps on both stakes.



Figure 6.32. Strap-and-grommet system for staking trees. Stakes should be located outside of rootball in solid ground.

3. This is the most commonly used method. Fasten three wires to stakes that have been fixed in firm soil around the edge of the planting hole at an equal distance from the hole and from each other. Stakes are generally used on smaller plants. They should be driven 18 to 24 inches into the ground at a 45-degree angle away from the tree trunk. It is absolutely essential all three stakes be firmly fixed so they will not pull out in high winds. The tops of the stakes are notched to hold the wire. The wire is then fastened to straps, which are fastened $\frac{2}{3}$ of the way up the trunk by a loose loop. The other ends of all wire should be fastened equally tight to the stakes without putting a strain on the trunk. The wires should be firm, but loose enough to allow slight movement of the tree, a factor essential to its proper development.

All support should be removed from small trees within one year after planting. The tree should have become established within this period of time. Growth and trunk strength are reduced if the supports are left in place for longer periods.

Watering

Newly planted trees and shrubs should be well watered at planting time. Young trees need an

equivalent of 1 inch of rain per week as a minimum. Newly planted trees and shrubs may need to be watered two or three times a week in extremely hot, dry weather because their root system cannot take up the needed amount of water to replenish the water transpired by the growing leaves. Signs of wilting usually indicate the tree or shrub needs water.

Apply water slowly at the base of the newly planted trees and shrubs. This is especially important for container-grown plants, as their soilless mixes can be dry while, the bed or surrounding soil remains damp.

Mulching

Keep a 4- to 6-foot, grass- and weed-free circle around young trees and shrubs the first two to three years. Keep the area covered with 2 to 3 inches of organic mulch, such as leaf mold, compost, shredded hardwood bark, well-rotted manure, grass clippings or straw. Never apply mulches if they have been recently exposed to herbicides. The herbicides may damage or kill the plant.

A 2- to 3-inch layer is usually sufficient for one season. This helps conserve moisture, retard weed growth and maintain a more even soil temperature for newly planted trees or shrubs. For fall transplants, mulch can increase to 4 or 5 inches. The deeper mulch will delay deep frost penetration, allowing more time for root growth and establishment. Keep mulch at least 2 to 4 inches away from the trunk of trees.

DO NOT use plastic under the mulch to prevent weeds. Roots are drawn to the surface and can be damaged by summer heat and winter cold. The plastic also prevents air and moisture exchange in the soil, stressing the plant. Landscape fabrics, which allow air and water to pass through, block weeds while allowing the plant to develop a healthy root system. Do not use rock mulches as they transfer heat directly to the roots. Do not mound mulch up against the trunk of trees or shrubs. Keep the mulch 2 to 4 inches away from the trunk; this is particularly helpful in preventing rodent damage during winter months. Excessive mulch against a trunk may also result in an environment favorable to disease and insect attack.

Wrapping

Young, thin-barked trees such as maples and other species often sunscald unless protected.

The twigs that shade the trunk should be left, but cut back a few inches so they become denser. A twiggy trunk is preferable to tree wraps, but not all trees have enough twigs, nor is it always practical or aesthetically pleasing to leave lower limbs.

Commercial tree wraps are available and may provide protection for thin-barked trees. Plastic wraps may provide better protection than paper wraps against lawn mower, trimmer and rodent damage. If misused, damage may occur in the form of trunk girdling or constriction, insects, disease and excessive moisture.

Protective wraps may not be necessary at planting. Tree trunk wraps are normally applied between October and March for the first two growing seasons. Wraps should be removed each spring prior to spring growth. During spring growth, the trunk expands and increases in size. Wraps applied too tightly or left on during this time may result in trunk constriction. Tree wraps should be applied loosely from the base up to the first branch by overlapping for a shingle effect. Plastic wraps should fit loosely and include holes or slits for good air movement. Periodically inspect the wraps for trunk damage and insects.

Seedling trees and shrubs may need a shelter during weather extremes in winter and summer. Cheesecloth or various other windbreaks can be used. Unfortunately, antidesiccants do not relieve plant stress with Oklahoma conditions.

Fertilizing

A new tree has a very limited capacity of utilizing fertilizer until it becomes established. Fertilization is not recommended at planting. Excessive fertilizer in the root zone can be damaging, so do not add it to the back fill. If fertilizer is needed based on a soil test, apply a controlled release or liquid fertilizer.

Do not dump fertilizer into the bottom of the planting hole. Fertilize young plants on the soil surface after the first two to three growing seasons. Small amounts of fertilizer applied regularly are preferred to one large dose.

Transporting and protecting ornamentals

It is important to plan ahead to allow sufficient time to transplant ornamentals so digging and planting are done without delay. From the time a plant is dug until it is planted in its new location, the

roots should never be allowed to dry. Prolonged exposure to air will cause the roots to dry out and die. Determine the new location and prepare the new hole before digging the plant. However, packing them in moist straw, sphagnum, peat moss, bark or other suitable material and wrapping with moist burlap can protect roots. Tops of plants should be protected from drying winds when transporting them by car or truck. Cover the shoots with a sturdy fabric or transport in a covered van or truck. Guard against trunk and stem injury by using protective padding.

Ten tips for planting and caring for new trees

- Dig the planting hole two to three times the diameter of the tree's rootball.
- Avoid digging the hole too deep, since the tree should be planted at its original grade or slightly higher (1 to 2 inches above grade). If the tree is planted above grade, it is important to cover the edges of the exposed rootball with soil tapered down to the surrounding soil line.
- Fill in the planting hole with native soil and tamp lightly. Avoid soil amendments.
- Do not over fertilize the new tree. A newly planted tree has a very limited capacity for utilizing fertilizer until it starts to establish itself.
- Stake young trees (top-heavy or planted in windy areas) when necessary, but allow for sway. Remove all stakes after the first season if possible.
- Avoid overpruning new trees. Try to leave lower limbs intact the first season.
- Keep a 4- to 6-foot weed- and turf-free circle around the tree for at least two years. Place an organic mulch (pine bark, straw, etc.) 2 or 3 inches deep around the tree; keep mulch a couple inches away from base of the tree trunk. Do not put plastic under mulch.
- Apply at least 1 inch of water weekly.
- Wrap young trees as fall approaches. Tree wraps protect tender bark from rodent damage and environmental stresses as a result of temperature fluctuations. Note that some young trees benefit from summer wrapping to avoid sunscald.
- Winter irrigate when temperatures remain above freezing for more than a few days to avoid dehydration injury.

Care and Maintenance

Landscape plants require periodic maintenance to produce the best results. This includes fertilization, winterizing, mulching, watering and pruning.

Fertilizing trees and shrubs

Ornamental trees and shrubs planted in fertile, well-drained soil or in a regularly fertilized lawn should not require annual fertilization. Trees and shrubs that are growing well don't require extra nutrients. If trees and shrubs are doing poorly, fertilization may be helpful, but only after the problem causing poor growth has been corrected.

Poorly growing plants will exhibit any or all of these symptoms:

- light green or yellow leaves
- leaves with dead spots
- leaves smaller than normal
- fewer leaves and/or flowers than normal
- short annual twig growth
- dying back of branches at the tips
- wilting of foliage

These symptoms of poor growth may be caused by inadequate soil aeration, moisture or nutrients; adverse climatic conditions; wrong pH; disease; or other conditions. Attempts should be made to determine the specific cause in each particular situation so appropriate corrective measures can be taken. Do not assume an application of fertilizer will quickly remedy any problem encountered. Soil and leaf tissue analyses are necessary to prescribe correct solutions.

The cause of poor growth may or may not be evident. Ornamentals transplanted or those whose roots have been disturbed by construction within the past 5 or 10 years may be in shock. Traditionally, pruning has been recommended to bring the top growth into balance with the reduced root system; however, recent research indicates such pruning may be detrimental. Efforts should be concentrated on maintaining the existing foliage that produces the necessary photosynthates to regenerate injured roots. Irrigation, aeration and fertilization are all recommended to keep leaves on the tree.

Most trees and shrubs tolerate a wide range of soil acidity. A range of pH 6.0 to 7.5 is suitable for most landscape plants. They usually will make sat-

isfactory growth without special treatment to raise or lower the pH of the soil. Plants such as azalea, blueberry, camellia, pin oak and rhododendron are exceptions. They grow best in an acid soil with a pH of 5.0 to 5.5. On soils with a pH of 6.0 or higher, these acid-loving plants may become quite yellow and grow poorly. Soils in eastern Oklahoma tend to be more acidic, and therefore, more suitable for acid-loving plants.

Fertilizer for small trees and shrubs should be based on soil analysis. Spread fertilizer evenly under the branches in late winter or early spring. As with turfgrasses, fall fertilization has been shown to be beneficial to poorly growing plants.

Large trees that need fertilization require large doses of nitrogen. Research indicates complete fertilizers are usually not essential and the growth response is primarily associated with nitrogen fertilization. On large trees, fertilizer applications should be concentrated at the dripline of the tree, which is the area directly below the outermost tips of the branches. The feeding root system of the tree is in this perimeter and, consequently, is where fertilizer and water should be applied. Placing fertilizer in small holes in the soil has been tested and research now indicates that surface application of fertilizer is sufficient.

Depending on the reason a large tree is doing poorly, fertilization might be needed each year. However, a feeding program must be combined with proper cultural practices. For example, neglecting necessary insect or disease control and failure to remove dead wood from a large shade tree will negate the positive effects of fertilization. Fertilizer is not a substitute for water during drought.

A moderate growth rate and good green color are all that is desired of woody plants. Excessive vigor, evidenced by lush green leaves and long shoot growth, is undesirable. Such plants require more maintenance, are more susceptible to winter cold injury and are more likely to be broken during wind or ice storms. These plants also will usually have a shorter life than woody plants with moderate growth rates.

Mulching

For year-round benefits of mulching, apply a 2-inch mulch of compost, shredded bark or wood chips around shrubs, roses and recently planted trees. This mulch will conserve moisture and help suppress the growth of weeds and grass. A 2-inch

layer should be used under the branches of shrubs and roses of all ages.

A circular area of mulch should be maintained for at least three or four years around newly planted ornamental trees. It should extend at least 3 feet from the trunk and be renewed as often as necessary to maintain a layer 2 inches thick. A circle of mulch will make it easier to mow around young trees without damaging the bark.

In some cases, mice may tunnel in the mulch and cause damage by chewing the bark from the stems of shrubs or trunks of trees. This is more likely to happen when coarse materials like straw, hay or pine needles are used. The best control is to keep the mulch back about 6 inches from the stems or trunk and trap or poison the mice.

Both organic and inorganic mulches can be useful in the landscape. Some of the more readily available and more commonly used mulches include sawdust, compost, pine needles, rock, gravel and woven plastics.

Watering the landscape

Of the tremendous amounts of water applied to lawns and landscapes, much of it is never absorbed by the plants. Some water is lost to runoff by being applied too rapidly, and some water evaporates from exposed, unmulched soil. But the greatest waste of water is applying too much too often. By simply using effective and efficient watering methods, irrigation requirements can be cut by 10 to 30 percent, plus landscape beauty and quality can be increased dramatically.

Correct watering of plants is vital for developing and maintaining a landscape planting. Lack of water can cause a plant to wilt, and ultimately die. Excessive water can cause root rot, in which case the plant wilts because it is oxygen-starved, and consequently, is unable to take up moisture. As a rule, plants are capable of withstanding moderate drought more easily than too much moisture. For this reason, it is important to water thoroughly, yet allow the soil to become fairly dry between waterings.

Wilting is a condition brought about in plants when roots are unable to supply sufficient moisture to the stems and leaves. Wilting for short periods of time will not harm plants; but over a prolonged period will cause permanent damage. Sometimes a plant will wilt on a hot day because moisture is evaporating from the leaves faster than the roots

can supply it. If there is ample soil moisture, the plant will absorb water in the evening to firm up the stems and leaves. However, when leaves remain wilted the following morning, watering is recommended.

It is difficult to make broad recommendations about when to irrigate due to tremendous variations in climatic conditions. However, when there is an extended period without rain during summer, newly planted trees and shrubs should be deeply watered once a week. By allowing the soil surface to dry out somewhat between waterings, major root development is encouraged at greater depths where soil moisture is highest. Plants watered frequently, but lightly are more apt to proliferate roots close to the surface, making them more vulnerable to wilting. This happens with automatic overhead sprinkler systems that are designed only to moisten the surface and run for a short period of time each night.

Environmental conditions are the primary factor affecting plant water needs. During cool seasons, less watering is necessary because evaporation from the leaves and soil is slow. During dry autumn or winter days and before the ground freezes, water all garden plants thoroughly to help prevent root damage from cold winter temperatures. Damage from unusually cold temperatures around the roots shows up in the spring in the form of leaf drop because there are not enough roots



Figure 6.33. Too much mulch (often called a mulch volcano) can weaken the bark and lead to serious problems.

to support the foliage. Water use under clear blue skies can be twice as high as use under cloudy conditions.

The best time to water is in the morning or evening, when air temperatures are lower than at midday. In the evening, do not wet foliage because this can encourage fungus or mildew, making plants unsightly and jeopardizing their health. Be prepared to control diseases if irrigating at night.

Trees and shrubs. All trees and shrubs need more frequent watering from planting time until becoming well rooted, which may take two growing seasons. Once established, water-efficient plants can then be weaned to tolerate less frequent watering. Proper weaning develops deep roots and makes the plants more drought tolerant.

Water established trees, shrubs and groundcovers infrequently, yet thoroughly. In the absence of rain, most trees and shrubs benefit from a once-a-month thorough watering during the growing season. Remember, normal lawn watering is not necessarily a substitute for thorough tree and shrub watering.

The feeding root system of a tree or shrub is located within the top 12 to 18 inches of the soil and at the dripline of the plant. The dripline is the area directly below the outermost reaches of the branches. Apply water and fertilizer just inside and a little beyond the dripline, not at the trunk. An effective way to water trees and large shrubs is to simply lay a slowly running hose on the ground at the dripline. Move the hose around the dripline as each area becomes saturated to a depth of 8 to 10 inches. For large trees, this watering technique may take several hours. A general rule is that 1 inch of water penetrates 6 inches of soil. If a sprinkler is set up to water a group of plants, a can with straight sides such as a coffee or tuna can, should be placed in range of the sprinkler. When 1 inch of water accumulates in the can, 1 inch of water has been distributed in the soil.

Container-grown landscape plants may be susceptible to drought stress once they are transplanted to the landscape. Drought stress occurs because the well-drained organic mix in which the plants are grown in the nursery is prone to rapid loss of moisture due to plant transpiration (loss of water from plant leaves) and evaporation from the soil surface. Even though moisture is available in the soil surrounding the organic mix, it does not move into the transplanted root ball rapidly enough

to prevent moisture stress from developing. Research has shown that the available moisture in the container mix can be depleted in about two days in the absence of irrigation. For this reason, these plants are watered at least every other day while in the nursery. This routine should be followed after transplanting until the root system penetrates the surrounding soil backfill (approximately 3 to 4 weeks) where moisture is available for absorption by the plant.

Care should be taken not to allow the transplanted root ball to dry out because the organic mix is very difficult to rewet once it becomes dry. Water can be applied to a drought-stressed plant where the root ball has become very dry and not successfully relieve the moisture stress because the medium does not readily absorb the applied water. In this case, water should be applied two or three times each day until the root ball has been rewet.

Learn the cultural requirements of plants being grown. Different plants have different water needs; good reference books should provide information on various water requirements. For example, azaleas require more moisture than cacti. It is particularly important to irrigate evergreen plants during winter. Evergreen leaves continue to lose water during winter, especially when the temperature is above 40 F. If the soil is dry, the plants may become desiccated, turn brown and die. Therefore, water shrubs several times during winter if soil moisture is low.

Know the condition of the soil. It is important to observe how quickly soil dries out after a rain or watering. For example, a clay soil will need less watering than a sandy one. Clay soil drains slowly, sandy soil quickly. The addition of organic matter to the soil will increase drainage in clay soil and moisture retention in sandy soil. When preparing a hole for planting, if the subsoil at the bottom of the hole is very hard and prevents water from draining quickly, it should be broken up with a shovel or pick.

Irrigation systems

The goal of any irrigation system is to supplement natural rainfall to give plants a sufficient amount of water without waste. By zoning an irrigation system, grass areas can be watered separately and more frequently than groundcovers, shrubs and trees. Both sprinkler and drip irrigation can be

incorporated to achieve water conservation in the landscape.

Sprinkler irrigation. Sprinkler irrigation is the most commonly used method of landscape watering. The two most common types of sprinkler irrigation systems are the hose-end sprinkler and the permanent underground systems. Even though a permanent sprinkler system is more water efficient than a hose-end sprinkler, both systems require little maintenance and apply large volumes of water in a short time.

If a permanent sprinkler system is used, make sure the sprinkler heads are adjusted properly to avoid watering sidewalks and driveways. Also, a properly adjusted sprinkler head sprays large droplets of water instead of a fog or fine mist. A mist is more susceptible to evaporation and wind drift.

With either hose-end sprinklers or permanent systems, water between late evening and mid morning to avoid excessive waste through evaporation.

Drip irrigation. In the future, drip irrigation may become the most common and efficient way to water a landscape. Presently, drip irrigation is not as widely used as sprinkler irrigation. Fear of the unknown is probably the biggest reason drip is not used more often. New equipment, which is more user friendly, has been developed in recent years. In fact, watering lawns with subsurface drip irrigation is being more widely accepted and used in home and commercial landscapes and sports turf.

Drip irrigation slowly applies water to soil. The water flows under low pressure through emitters, bubblers or micro-spray heads placed at each plant. Or, the emitters are fastened inside a hose (called tubing) by the manufacturer. The goal is to water the entire rootzone of a plant or bed of plants, instead of watering individual plants. These products are called tape-type drip or in-line drip tubing. Regardless of the type of drip products used, water applied by drip irrigation has little chance of waste through evaporation or runoff.

Seeking professional irrigation advice and experimenting with available drip irrigation products in small sections of the landscape are the best ways to become familiar with the many benefits of this watering technique.

Pruning landscape plants

To prune or not to prune? This is a question gardeners often face. Many feel they should prune, but are not sure why or how. Pruning is an accepted practice for the orchard and fairly frequent in the rose garden, but it may be rather haphazard in the landscape. Most often it is only performed when a shrub or tree begins to encroach on surrounding plants, a path or a building.

Pruning is the removal of a part or parts of a woody plant for a specific purpose. This section explains the reasons for pruning, the proper techniques and when various types of plants should be pruned.

Reasons for pruning

Pruning is done for the following reasons:

- To train the plant
- To maintain plant health
- To improve the quality of flowers, fruit, foliage or stems
- To restrict growth

Training trees. The first pruning after trees and shrubs are received consists of removing broken, crossing and pest-infested branches. The traditional rule of pruning one-third of the top growth at transplanting to compensate for root loss is no longer valid for properly pruned, nursery-grown plants. According to recent research, excessive pruning at transplanting reduces plant size and does not aid in plant survival.

The central leader of a tree should not be pruned unless the leader is unwanted, as is the case with some naturally low-branched trees or where multiple-stemmed plants are desired. Trees with a central leader, such as Shumard oak, sweet gum or magnolia, may need little or no pruning except to eliminate branches competing with the central leader. These competing branches should be shortened. Some pruning may be necessary to maintain desired shape and to shorten extra-vigorous shoots.

The height of the lowest branch can range from a few inches above the ground for screening or windbreaks to more than 7 feet high when the tree is near a street or patio. Removal of lower limbs is usually done over a period of years beginning in the nursery and continuing for several years after transplanting until the desired height is reached. The concept in training a tree called “the trashy trunk” refers to this gradual raising of the lowest

branches of a tree. Lower branches on the main trunk help create a thicker trunk more quickly. A common mistake in pruning young trees is to strip them of small branches, leaving only a tuft of leaves at the top of the tree. This training is incorrect and forms a weak, “buggy whip” trunk. Remove lower limbs when they reach 1 inch in diameter. This prevents permanent scarring of the trunk caused by removing larger limbs.

Another important concept in training trees is light versus heavy cuts. This refers to the length of the branch being removed and the desired growth response of that branch. On a young, vigorously growing branch, if the terminal end is lightly cut back (less than 6 inches), then lateral branching is induced up and down the branch. On the contrary, if this branch is heavily cut back (from 6 inches to several feet), the one or two buds located just below the cut are forced and grow at a very rapid rate. The importance of this pruning concept lies in the development of bushy, well-shaped trees through light pruning.

For greatest strength, branches selected for permanent scaffolds must have a wide angle of attachment to the trunk. Branch angles less than 30 degrees from the main trunk have a very high percentage of breakage, while those between 60 and 70 degrees have a very low breakage rate.

Vertical branch spacing and radial branch distribution are important (Figure 6.34). If this has not been done in the nursery, it can be started at transplanting.

Major scaffold branches of shade trees should be vertically spaced at least 8 inches apart and preferably 20 to 24 inches apart. Closely spaced

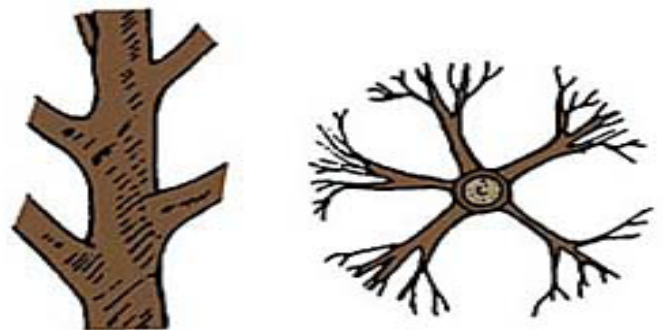

Figure 6.34. Scaffold branches of trees should have proper vertical and radial spacing on the trunk.

scaffolds will have fewer lateral branches, resulting in long, thin branches with poor structural strength.

Radial branch distribution should allow five to seven scaffolds to fill the circle of space around a trunk. Radial spacing prevents one limb from overshadowing another, which in turn reduces competition for light and nutrients. Remove or prune shoots that are too low, too close or too vigorous in relation to the leader and selected scaffold branches.

Maintaining plant health. In pruning to maintain plant health, the first consideration is sanitation to eliminate dead, dying or diseased wood. Any dying branch or stub can be the entry point or buildup chamber for insects or fungi that could spread to other parts of the tree. When removing wood infected by disease, such as a fungal canker or fire blight, it is important that the cut be made in healthy wood beyond the point of infection.

The development of a sound framework will help prevent branches from shading other branches lower on the plant. Evergreen shrubs will usually benefit from an occasional thinning of foliage. Thinning allows light and air to penetrate throughout the shrub, resulting in even foliage growth.

Improving the quality of flowers, Fruit, foliage or stems. The more flowers and fruit a plant produces, the smaller they become, as seen on an unpruned rose bush or fruit tree. By reducing the amount of wood, pruning diverts energy into the production of larger, though possibly fewer, flowers and/or fruit. Most flowering shrubs will bloom either on last year's growth or on new growth. Properly timed pruning increases the production of wood that bears flowers.

Restricting growth. Over time, trees and shrubs often grow to sizes exceeding the space allowed of them. When space is limited, regular pruning becomes necessary to keep plants in bounds. Regular pruning is necessary on formal hedges to maintain a uniform growth rate. To reduce labor, select plants that will not exceed allotted space. Know the mature size of the plants and place them accordingly in the landscape.

Pruning techniques

Through the years, great discussions (arguments) have been had concerning pruning techniques from topping to hedge clipping. The following techniques are well documented and provide guidelines in pruning trees and shrubs properly.

Pruning twigs and small branches.

When pruning twigs and small branches, always cut back to a vigorous bud or an intersecting branch; when cutting back to a bud, choose a bud that is pointing in the direction you wish the new growth to take (Figure 6.35). Be sure not to leave a stub over the bud or cut too close the bud.

When cutting back to an intersecting (lateral) branch, choose a branch that forms an angle less than 45 degrees with the branch to be removed. Also, the branch being cut back should have a diameter at least half that of the branch to be removed. Make slanting cuts when removing limbs that grow upward; this prevents water from collecting in the cut and expedites wound closure.



Figure 6.35. Proper pruning of twigs is demonstrated on the left. The others are improper cuts – too steep an angle, not close enough and too close.

Pruning thick, heavy branches. According to Dr. Alex Shigo, plant pathologist at USDA Forest Service, thick and heavy branches should be removed flush to the collar at the base of the branch, not flush with the trunk (Figure 6.36). The collar is an area of tissue that contains a chemically protective zone. In the natural decay of a dead branch, when the decay advancing downward meets the internal protected zone, an area of strong wood meets an area of very weak wood. The branch falls away at this point, leaving a small zone of decayed wood within the collar. The decay is walled off in the collar. When all goes according to nature's plan, this is the natural shedding process. When the collar is removed, the protective zone is removed, causing a serious trunk wound. Wood decay fungi can easily infect the trunk. If the pruned branch is living, removal of the collar at the base still causes injury.

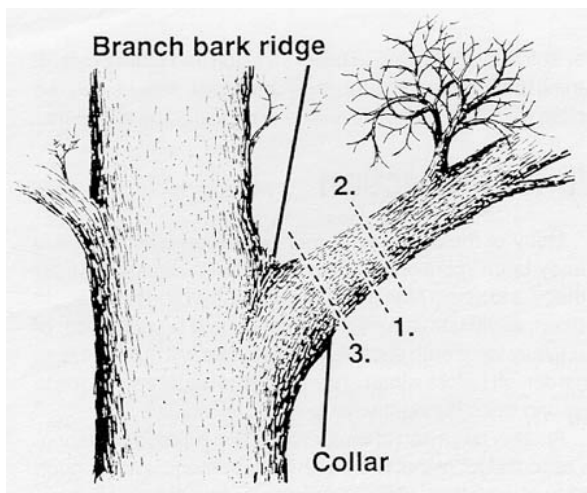

Figure 6.36. The three-step cutting method is used when removing large, heavy limbs.

When cutting branches more than 1 ½ inches in diameter, use a three-part cut. The first step is to saw an undercut from the bottom of the branch about 6 to 12 inches out from the trunk and about one-third of the way through the branch. Make a second cut from the top about 3 inches further from the trunk than the undercut until the branch falls away. The resulting stub can then be cut back to the collar of the branch. If there is danger of the cut branch damaging other limbs or objects on the ground, it should be properly roped and supported, then carefully lowered to the ground after the second cut.

For more than half a century, recommendations for pruning have been to flush-cut and paint. The flush-cut increases tree injury, and the paint only hides it. Pruning paint is primarily cosmetic, a psychological treatment for the person doing the pruning to show they have done something to “help” the tree. In fact, paints or wound dressings may trap moisture and increase disease problems. The only exception to the need for pruning paint is a result of the threat of disease. Painting freshly cut limbs seems to reduce the chance of infection caused by insects, which transmit disease through new wounds.

Topping versus thinning. All too often trees are topped (“dehorned”) to reduce size or rejuvenate growth. In either case, topping is not a recommended practice. Topping is the process whereby a tree is cut back to a few large branches (Figure 6.37). After two to three months, regrowth

on a topped tree is vigorous, bushy and upright. Topping can seriously affect the tree’s structure and appearance. The weakly attached regrowth can break off during severe wind or rainstorms. Topping may also shorten the life of trees by making them susceptible to attacks by insects and disease.

Thinning is a better means of reducing the size of a tree or rejuvenating growth. In contrast to topping, thinning removes unwanted branches by cutting them back to their point of origin. Thinning conforms to the tree’s natural branching habit and results in a more open tree, emphasizing the branches’ internal structure. Thinning also strengthens the tree by forcing diameter growth of the remaining branches.

Pollarding. Pollarding is a pruning technique used extensively in Europe. It results in thousands of healthy trees lining city streets in what is considered a very adverse environment. For example, London planetrees have lived for 100 years through the use of pollarding. In a sense, pollarding allows an urban home gardener to grow a “bonsai” of a mature tree.

Pollarding is often confused with topping; both techniques severely prune the tree back to large diameter branches. The difference is that with



Figure 6.37. Topping is never warranted and can shorten the life of the tree.

pollarding, follow-up thinning is performed one and perhaps two years later. By thinning out the dense flush of new growth, the tree's integrity and strength are assured.

Pruning deciduous shrubs. Pruning recommendations for most deciduous shrubs include thinning out, gradual renewal and rejuvenation pruning. In thinning out, a branch or twig is cut off at its point of origin from either the parent stem, a lateral side branch the "Y" of a branch junction or at ground level (Figure 6.38). This pruning method results in a more open plant; does not stimulate excessive new growth but does allow room for growth of side branches. Considerable growth can be cut off without changing the plant's natural appearance or habit of growth. Plants can be maintained at a given height and width for years by thinning out. This method of pruning is best done with hand pruning shears, loppers or a saw, but it should not be done with hedge shears. Thin out the oldest and tallest stems first.

In gradual renewal pruning, a few of the oldest and tallest branches are annually removed at or slightly above ground level (Figure 38). Some thinning out pruning may be necessary to shorten long branches or maintain a symmetrical shape.

To rejuvenate an old overgrown shrub, remove one-third of the oldest, tallest branches at or slightly above ground level before new growth starts.

The general pruning procedure shown for crapemyrtle (Figure 6.39) applies to many large shrub and small tree species. In general, Crape-myrtles require little pruning and the common practice of butchering them back to stubs each year should be avoided. Instead only remove or

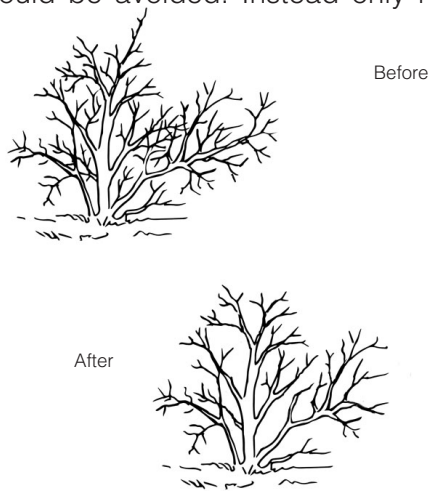

Figure 6.38. Thinning and gradual renewal pruning of deciduous shrubs.

**Proper method of pruning
Crapemyrtle**



This plant, before pruning, need to have all weak and dead stems removed.



Same shrub after removal of weak and interfering wood and base sucker growth.



Results of proper pruning are graceful, vigorous growth and distinctive shape.

**Improper method of pruning
Crapemyrtle**



Cutting on the dotted line is the usual course taken by those who prune shrubs



The same plant after bad pruning, as indicated above. The sucker growth remains.



Results: the lovely natural shape of the shrub is lost and blooms will be sparse.

Figure 6.39. Proper pruning of crapemyrtle.

cut back branches and twigs with winter damage and thin out to see through the shrub instead of seeing over it.

If annual pruning of crapemyrtles is a result of a plant growing too big for the area, consider replacing it with a dwarf or miniature form of crape-myrtle. Many new cultivars are available of all sizes, including tree forms and groundcover forms, which will reduce the need for annual pruning.

If a shrub is grown for its flowers, pruning must be timed to minimize disruption of blooming. Spring flowering shrubs bloom on last season's growth and should be pruned soon after they bloom. This allows for vigorous summertime growth and results in plenty of flower buds the flowing year. Examples of shrubs that bloom on last season's growth include the following:

- | | |
|--------------------|------------------------|
| <i>Amelanchier</i> | Shadblow, Serviceberry |
| <i>Chaenomeles</i> | Flowering quince |
| <i>Chionanthus</i> | Fringetree |

<i>Cotinus</i>	Smoketree
<i>Forsythia</i>	Forsythia
<i>Lonicera</i>	Honeysuckle
<i>Philadelphus</i>	Mockorange
<i>Pyracantha</i>	Firethorn
<i>Rhododendron</i>	Rhododendron and Azalea
<i>Rosa</i>	Climbers and other shrub roses
<i>Spiraea</i>	Early white spirea species
<i>Syringa</i>	Lilac
<i>Viburnum</i>	Viburnum
<i>Weigela</i>	Weigela

Some shrubs that bloom after June usually do so from buds that are formed on shoots grown the same spring. Such shrubs should be pruned in late winter to promote vigorous shoot growth in the spring. Examples of shrubs that bloom on current season's growth include the following:

<i>Abelia x grandiflora</i>	Glossy Abelia
<i>Buddleia davidii</i>	Butterfly bush
<i>Callicarpa</i>	Beautyberry
<i>Hibiscus syriacus</i>	Shrub althea
<i>Hydrangea arborescens</i>	Smooth hydrangea
<i>Hydrangea paniculata</i>	
'Grandiflora'	P. G. hydrangea
<i>Hypericum</i>	St. Johnswort
<i>Rosa cvs.</i>	Hybrid tea roses

Pruning evergreen shrubs. For most evergreen shrubs, thinning out is the most desirable pruning procedure. Some evergreens can be sheared for a stiff, formal appearance; however, they still need to be thinned occasionally. Prune both evergreen and deciduous shrubs grown for foliage in late winter before new growth starts. Minor corrective pruning can be done at any time.

Pruning hedges. Hedges are a row of plants that merge into a solid linear mass. They have served gardeners for centuries as screens, fences, walls and edgings.

A well-shaped hedge must be trained from the beginning. The establishment of a deciduous hedge begins with the selection of nursery stock. Choose young trees or shrubs 1 to 2 feet high, preferably multiple stemmed. Cut the plants back to 6 or 8 inches when planting; this induces low branching. Prune off half of the new growth late in the first season or before bud break in the next season. In the following year, again trim off half.

In the third year, start shaping. Trim to the desired shape before the hedge grows to its desired size. Never allow the plants to grow untrimmed to the final height before shaping; by that time, it is too late to get maximum branching at the base. Do not allow lower branches to be shaded out. After the hedge has reached the desired dimensions, trim closely to keep the hedge within chosen bounds.

Evergreen nursery stock for hedging need not be as small as deciduous material and should not be cut back when planted. Trim lightly after a year or two. Start shaping as the individual plants merge into a continuous hedge. Do not trim too closely because many needle-bearing evergreens do not easily generate new growth from old wood.

Hedges are often shaped with flat tops and vertical sides; however, this unnatural shape is seldom successful. As far as the plant is concerned, the best shape is a natural form with a rounded or slightly pointed top and with sides to a wide base (Figure 6.40).

After plants have been initially pruned to induce low branching, the low branching is maintained by trimming the top narrower than the bottom so sunlight can reach all of the plant leaves (Figure 6.41).

These questions often arise and the answers depend to some extent on how formal an appearance is desired. How often should this hedge be trimmed? When should I trim? In general, trim before the growth exceeds 1 foot. Hedges of

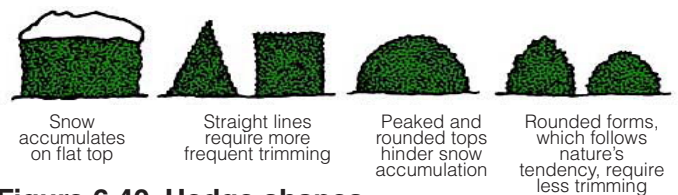

Figure 6.40. Hedge shapes.

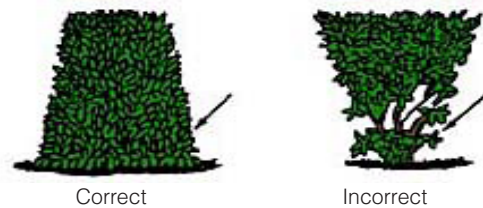

Figure 6.41. Proper hedge pruning.

slow-growing plants such as boxwood need to be trimmed sooner. Excessive untrimmed growth will kill lower leaves and will pull the hedge out of shape. Trimming frequency depends on the kind of shrub, the season and desired neatness.

What can be done with a large, overgrown, bare-bottomed and misshapen hedge? If it is deciduous, the answer is fairly simple. In spring before new leaves appear, prune to 1 foot below the desired height. Then carefully trim for the next few years to give it the desired shape and fullness. Hedge plants may occasionally decline too much to recover from this treatment, making it necessary to replace them.

Rejuvenating evergreen hedges is more difficult. As a rule, evergreens cannot stand the severe pruning described. Arborvitae and yew are the exceptions. Other evergreen hedges may have to be replaced.

Tools. What tools should be used to trim hedges? The traditional pair of scissor-action hedge shears is still the best all-around tool. It will cut much better and closer than electric trimmers, which often break and tear twigs. Hand shears can be used on any type of hedge, while electric trimmers do poorly on large-leaved and wiry-twigged varieties, and sometimes jam on thick twigs. Hand shears are also quieter, safer and are less likely to gouge the hedge or harm the operator.

Hand pruners are useful in removing a few stray branches and are essential if an informal look is desired. Large individual branches can be removed with loppers or a pruning saw. Chain saws are not recommended for use on hedges.

Pruning roses. All roses need some type of pruning. If roses are not pruned for a number of years, the plants deteriorate in appearance, flowers become smaller and smaller, and disease and insect problems are more likely.

Hybrid Tea, Grandiflora and Floribunda roses require annual pruning in the spring just prior to bud break. If rosebushes are pruned too early, injury from late frost may make a second pruning necessary.

Steps in pruning. Begin in late winter by removing all dead and diseased wood at least 1 inch below the damaged area. Remove all weak shoots. If two branches rub or are close enough to do so soon, remove one. On old, heavy bushes, cut out one or two of the oldest canes each year.

Cut back the remaining canes. The height to which a rose should be cut back varies, depending on the normal growth habit of the particular cultivar. The average pruning height for Floribundas and Hybrid Teas is between 12 and 18 inches, but taller-growing Hybrids and most Grandifloras may be left at 2 feet.

Make cuts at a 45 degree angle above a strong outer bud. Aim the cut upward from the inner side of the bush to push growth outward and promote healthy shoots and quality flowers.

Other types of roses have special pruning considerations, some of which are described below.

Standard or tree roses. A tree rose is a Hybrid Tea, Grandiflora or Floribunda budded at the top of a tall trunk. Prune tree roses as you do Hybrid Teas, cutting the branches to within 6 to 10 inches of the base of the crown to encourage rounded, compact and vigorous new growth.

Miniature roses. Miniature roses are 6 to 12 inches high with tiny blooms and foliage. Miniature roses do not need special pruning; just cut out dead growth and remove the hips.

Ramblers. Old-fashioned rambler roses have clusters of flowers, usually less than 2 inches in diameter. They often produce pliable canes 10 to 15 feet long in one season. Ramblers produce best on 1-year-old wood; this year's choice blooms come from last year's growth. Prune immediately after flowering. Entirely remove some of the large old canes, and tie new canes to a support for next year.

Large-flowering climbers. Climbing roses have flowers more than 2 inches across that are borne on wood two years old or older. Climbing rose canes are larger and sturdier than Rambler canes. Some climbing roses flower only in June, but others called ever-blooming climbers, flower more or less continuously. This group should be pruned in autumn before cold weather sets in. First, cut out dead and diseased canes. Remove one or two of the oldest canes each season at ground level to make room for new canes. The laterals, or side shoots, are shortened 3 to 6 inches after flowering. If the plant is strong, keep five to eight main canes; these should be tied to a trellis, fence, wall or other support. If it is not strong, leave fewer canes.

Cultural and Environmental Problems

Leaf Scorch

Leaf scorch appears mid- to late-summer when tree or shrub leaves show a browning or drying at the outer margin or in the areas between the veins (Figure 6.42). The areas near the veins generally remain green. However the entire leaf may dry and fall prematurely in extreme cases. Scorch itself will not kill a plant, but may weaken it to the point where insects or disease pathogens can cause further injury. Scorch symptoms develop when leaves transpire (lose water by evaporation) at a faster rate than water can be absorbed through the roots. This can be caused by too little water in the soil or a physical restriction of the roots. Scorch symptoms usually appear during hot, dry, windy weather. Newly transplanted trees or trees planted in poorly selected sites, growing along streets or sidewalks (reflective heat) or in areas where the roots are restricted or underdeveloped seem to suffer the most.

Trees and shrubs most likely to develop scorch in Oklahoma include azalea, birch, dogwood, maples, oak, ornamental pear, redbud, rhododendron and sweetgum.

Deep watering during dry periods lessens, but does not eliminate leaf scorch. Planting trees adapted to Oklahoma's climate will lessen or prevent leaf scorch.



Figure 6.42. Leaf scorch.

Drought

Severe drought is likely to cause less injury to plants native to an area or are well adapted and established on a given site. Non-adapted trees and shrubs, on the other hand, often show symptoms of severe water stress. Perhaps more importantly, a water deficiency predisposes plants to infection by pathogens, attack by insects and injury by severe summer and winter weather extremes.

Drought damage develops in plants when the transpiration rate exceeds the rate of water absorption by the roots, as it does almost daily during the growing season. The water deficiency is normally made up at night or during periods of rain or dew formation, when transpiration slows or ceases. As soil dries, roots fail to absorb as much water as the tree has lost and physiological stress develops. If this condition intensifies, leaves wilt, turn yellow and die.

Drought damage also occurs in dormant plants, especially narrow-leaf and broadleaf evergreens. During warm weather in winter or early spring, water evaporates from leaves and stems, while the roots absorb little to no water from the cold or frozen soil.

Plants vary in their ability to tolerate drought. Recently transplanted plants are at greatest risk of drought damage. Trees or shrubs recently transplanted have lost many root hairs, so the creation of a water deficiency is unavoidable. Also, their root balls may contain a highly porous growing medium instead of soil, creating a water shortage even though the surrounding soil contains sufficient water for plant growth. This problem continues until roots grow beyond the root ball.

When green leaves wilt and turn brown, the oldest leaves usually succumb first. Severely stressed, deciduous species may drop all their leaves. Similarly, the oldest needles (nearest the trunk) on pine trees may turn yellow and drop. Drought symptoms on pine trees should not be confused with natural shedding of older needles. This can be discerned by experience and tracking of soil moisture levels.

Drought damage can be prevented by deep watering during dry periods throughout the year, including winter months when temperatures remain above freezing for prolonged periods. Also select plant species that tolerate drought conditions. The following are just a few examples of drought-tolerant plants: lacebark elm, goldenrain-

tree, hackberry, fruitless mulberry, bur oak, callery pear cultivars, Chinese pistache, smoketree and soapberry.

Winter burn of evergreens

Winter burn is common in Oklahoma for such plants as azalea, boxwood, holly, magnolia, rhododendron and viburnums, but it can affect narrow-leaf evergreens, pines and deciduous species as well. Winter burn is often misdiagnosed as an infectious disease or damage from excessively cold temperatures. Winter burn is caused from desiccation, which is a type of dehydration injury. When roots are in dry or frozen soil, the roots cannot replenish water lost through transpiration and dehydration occurs.

Water loss through transpiration is normally low during winter months, but it increases when plants are subjected to drying winds or are growing in warm sunny spots.

Symptoms of winter burn include scorching of leaf tips or outer margins, complete browning of needles or browning from the needle tips downward, or death of terminal buds and/or twigs (Figure 6.43).

Several means of eliminating or minimizing winter burn may be used. Avoid planting evergreens in areas of high wind exposure. Deep-water plants during dry periods throughout winter months when temperatures remain above freezing for prolonged periods. Erect physical windbreaks. Burlap "walls" can help cut down wind and subsequent moisture loss to evergreen shrubs and small trees (Figure 6.44). Antitranspirants of various types are available, but have shown limited success with Oklahoma's climatic conditions.



Figure 6.43. Winter burn on boxwood.



Figure 6.44. Burlap "walls" for wind protection.

Injury by freeze or frost

Plants undergo seasonal changes in their ability to tolerate low temperatures. In autumn, perennial plants become acclimated to withstand low temperatures. The degree of cold acclimation varies during winter in relation to ambient temperature. The hardiest trees or shrubs that are fully acclimated can withstand much lower temperatures. The majority of woody plants of the temperate zone become acclimated to withstand minimum temperatures between -4 F and -40 F. As temperatures rise in late winter and early spring, plants deacclimate until, by the time growth begins, they can no longer tolerate more than a few degrees below freezing.

Southwest injury

Southwest injury (Figure 6.45) is a local injury that develops on the south and southwest side



Figure 45. Southwest injury.

of the trunk or on the upper surfaces of limbs exposed to the sun. The temperature of the sun-warmed sides of limbs or trunks may exceed 68 F in late winter when the air temperature and the temperature of shaded bark barely exceed 32 F. This heating causes deacclimation, which is followed by lethal freezing when the temperature drops at night.

Damaged bark and cambium dry out, crack, separate from the wood and eventually fall away, exposing dead sapwood. Young trees with thin, smooth bark are most susceptible to this type of injury. Southwest injury has been diagnosed on trunks and limbs of flowering cherry, maple, callery pear, weeping willow, various fruit trees, ginkgo, red oak and Japanese pagodatree. Any other young tree with thin, green bark also is susceptible.

Winter freeze injury

Freezing during dormancy occurs when unusually warm weather in autumn retards acclimation, and/or warm weather in winter or early spring induce partial deacclimation. Most damage by freezing during winter follows untimely deacclimation during temporary warm weather. Often, after periods of unusual warmth, the temperature drops rapidly to a level normal or subnormal for the season and severe freeze damage can occur to plants that are marginally hardy in a given region.

The most common external symptoms caused by winter freezing are dieback, foliar browning, sunscald and bark splitting on the trunk or branches. Dieback of twigs and branches and foliar browning in evergreens commonly follow freeze injury when winter temperatures arrive suddenly



Figure 46. Winter freeze injury.

after warm autumn weather (Figure 6.46). Plants that survive may produce new branch systems from dormant or adventitious buds. Major freeze injury that kills the cambium leads to cankers, dieback and often wilting and death during the next growing season because water loss by transpiration cannot be sufficiently replaced by conduction through damaged wood.

Decay fungi can soon invade wood exposed by bark splitting or branch dieback. In trees prone to bacterial wetwood, elms for example, this condition becomes more widespread within trees after damage by freezing. Also, freezing insufficient to cause evident stress in plants may interfere with defenses against opportunistic fungal pathogens causing cankers, dieback, sapwood decay or root rot. Some of the common diseases for which predisposition is important include *Cytospora* canker on poplar, willow and cottonwood; dieback of sycamore and oak caused by *Botryosphaeria*; and *Sphaeropsis* (formerly *Diplodia*) tip blight of pine.

Secondary insects often join opportunistic fungi in the attack on stressed trees. Bark beetles and blue-stain fungi can attack stressed conifers. The two-lined chestnut borer and *Hypoxyton* fungal species attack stressed oaks, resulting in their death.

Hail damage

In Oklahoma, injuries to woody plants by hail commonly occur. Hail stones lacerate leaves, defoliate branches, remove twigs and/or bruise or break the bark of twigs and small branches. Bruises and wounds tend to be elliptically shaped and vary in length from 1/16 to 3 inches or more (Figure 6.47). Severe hail wounds may kill all the bark on one side of a stem, branch or trunk. All wounds occur on the upper sides of branches and on the side of the tree facing the storm. After the storm, bruised bark can crack as a result of drying and mechanical stress from the callus growth at the edge of the injured area. Application of pruning paint is not recommended for injured bark.

Ice damage

Ice damage is most destructive when a heavy glaze forms on plants during freezing rain. The weight of the glaze breaks twigs, branches and trunks. It can even uproot trees (Figure 6.48). The amount of damage increases if the wind rises before the ice melts. Trying to break off or remove ice



Figure 6.47. Hail damage.



Figure 6.49. Bark split and falling off after a lightning strike.



Figure 6.48. Ice damage.

prior to warmer temperatures can prove even more damaging to affected plants.

Lightning damage

Lightning can cause significant damage to landscape trees. Struck trees often have a strip of bark and sapwood blown off the trunk (Figure 6.49), leaving a continuous or intermittent rough groove that follows the wood grain. Trees that are struck, but not killed are likely to be disfigured by limb death. In addition, wounds and destroyed parts provide entry for borers and fungi that decay wood. Conifers weakened by lightning strikes may be attacked and killed by bark beetles.

Lightning rods are sometimes installed on large, valuable trees. Copper cables are directed down the trunk and through the soil to grounding rods driven into soil beyond the branch spread of the tree. However, some experts question the degree of protection these rods provide.

Damage by misapplied pesticides

Those who apply pesticides to plants or soil rely on the principle of selective toxicity. The pesticide is intended to suppress or kill specific plants or plant pests, while causing little or no damage to nontarget plants or pests. Environmental contamination and injury to nontarget plants can occur occasionally, even when all normal precautions are taken. However, such contamination and injury are more common when pesticides are mishandled or applied under improper conditions.

Herbicide injury. Herbicides are normally separated into two general categories in regards to their intended purpose – selective and nonselective herbicides. Selective herbicides are used to kill established broadleaf weeds in turf or landscape plantings. Well-known herbicides in this group include the phenoxyacetic acids (2,4-D, MCPA, MCPP and related compounds) and the benzoic acid derivative dicamba. These herbicides act as plant hormones that disrupt normal growth processes. Selective herbicides have the

potential to become nonselective when applied at rates higher than specified, improper environmental conditions or to plants not specified on product labels. Herbicides in this group may reach and enter nontarget plants by as many as three modes. The most common is absorption from droplets that drift from the site of application. A second mode of absorption is the gaseous phase caused by drifting vapor after the evaporation of spray droplets or of liquid on sprayed surfaces. This occurs with highly volatile herbicides in warm weather. The third mode is through soil, where roots absorb the herbicide. The phenoxy herbicide 2,4-D is the best known example of a chemical that may reach nontarget plants by any or all three modes. Dicamba is more likely to cause injury as the result of uptake by the roots.

The second group of herbicides includes chemicals intended to prevent emergence of weed seedlings (preemergence herbicides) or to kill all vegetation to which they are applied (soil sterilants). Some of these herbicides persist in soil for a year or more. Some preemergent herbicides result in unwanted residual effects after application to landscape soils. Herbicides such as glyphosate will kill all vegetation, but will not persist in the soil. The use of herbicides with short-term residual is ideal in the landscape, since plants may be safely introduced (planted) into a treated area.

Soil sterilants sometimes cause trouble for nontarget trees or shrubs when sprayed on target plants or applied to areas adjacent to landscapes. These herbicides are commonly used to control vegetation along highways, railroads, fences, power lines and similar places. Never use soil sterilants in a landscape setting.

Symptoms of herbicide injury vary with the type of chemical and are not easily diagnosed, except for the atypical growth caused by hormone-type herbicides. Some diseases, insects, insufficient or excessive water or heat can cause symptoms similar to those caused by herbicides. Also, deficiencies of certain nutrients and other kinds of misapplied pesticides can mimic herbicide injury.

Tree or shrub roots growing in the area of the treated grass take up hormone-type herbicides. Such herbicides may cause drastic growth suppression, leaf cupping, bending and sometimes coiling of shoot tips, yellowing of new growth, bud failure, browning or blackening of foliage, defoliation and sometimes death (Figure 6.50). Hor-



Figure 6.50. Leaf damage from hormone-type herbicide.



Figure 6.51. Tip damage from hormone-type herbicide.

mone-type herbicides are translocated to growing points and cause multiple deformities in new leaves and shoots (Figure 6.51). Symptoms develop several days to several weeks after exposure or may appear in the spring following an autumn exposure. Nontarget plants usually receive sublethal doses and outgrow the symptoms within one to two years. Symptoms include cupped leaves; abnormally prominent veins; wavy, frilled or curled leaf margins; tough or leathery leaves; partial failure of chlorophyll development; delayed bud break in the spring; and abnormal purple coloration of normally green stems.

Preemergence herbicides and nonselective soil sterilants tend to halt growth and cause chlorosis of new and old leaves. If the dose is sufficient, they cause foliar browning, leaf cast and dieback of twigs and branches. Others cause marginal and interveinal chlorosis of broadleaf plants and at needle bases of conifers. Trees or shrubs severely injured by these herbicides are less likely to recover than plants injured by hormone-type herbicides.

Herbicides generally cause damage on plants treated or inadvertently exposed during growth in warm weather. Water shortage or heat stress may enhance toxic effects. Dormant plants or those in a resting phase are less sensitive. Herbicides are commonly applied to sites containing ornamental trees and shrubs. Careful attention should be given

to prevent drift to nontarget plants. There are many herbicides that should never be applied under or near the dripline of established trees or shrubs. Some may even cause damage when applied outside the dripline. Avoid using soil sterilants around ornamental plantings. Never apply long-lasting soil sterilants under new pavement or sidewalks if trees or shrubs are growing or will be planted nearby. Tree and shrub roots from nearby species will eventually grow into the site and translocate the herbicide throughout the plant. These trees will be severely injured or killed as a direct result of the soil sterilant applied (Figure 6.52). Purchase herbicides from nurseries or garden centers that are staffed by qualified individuals who can recommend the appropriate chemical control when necessary. To avoid drift, apply herbicides on calm days. When possible, use a coarse-droplet spray and apply at low pressure. Strive to use herbicides early in the morning when winds are likely to be calm. Excessive temperatures also can be avoided in the morning hours. Intense heat can cause phenoxy-type herbicides to volatilize and injure nearby nontarget plants. Also, avoid applying herbicides at their highest labeled rates in soils low in organic matter. Less herbicide is required for proper weed control in soils low in organic matter.

Phenoxy herbicides and dicamba are the weed killers that most commonly injure nontarget trees and shrubs. Most ornamental plants have varying degrees of sensitivity to these types of herbicides, so extreme care should be used when applying herbicides in the home landscape.



Figure 6.52. Soil sterilant damage.

Insecticide or fungicide injury. Plant injury by insecticides and fungicides is infrequent compared to that by herbicides. The active ingredients in modern insecticides and fungicides seldom cause visible symptoms unless applied at rates higher than specified, improper environmental conditions or to plants not specified on product labels.

Symptoms of plant injury by insecticides and fungicides are not usually diagnostic and cannot reliably be interpreted unless the history and treatment of the plant are known. Visible symptoms include yellow to brown leaf spots; chlorosis of the leaf tips, margins or interveinal areas; general chlorosis; browning of leaf margins or interveinal area; stunted shoots; and abnormal crinkling or curling of leaves. Foliar yellowing or browning is often followed by premature leaf drop.

Inorganic pesticides such as lime-sulfur and copper fungicides, including a Bordeaux mixture, can cause injury to many kinds of plants if not applied at the proper rate and the right environmental conditions. To prevent plant injury by pesticides, always read and follow the label directions. Choose pesticides that least affect the plants in the surrounding environment.

Grade changes and construction/oxygen deficiency

Cultivation. Many shrub and tree species decline from chronic movement or cultivation of even the top few inches of soil (Figure 6.53). The majority of critical roots reside in the top 10 to 14 inches of soil. Keep this in mind when annual flowers or spring flowering bulbs are desired around or underneath established woody ornamentals. Also, consider that roots grow beyond the dripline of a tree.

Spring flowering bulbs should be planted at the time when the tree or shrub is planted. Insert bulbs carefully at original soil grade when planting in later years. Always plant winter-hardy bulbs that can remain in place year-round, this will minimize disruption of the plant's root system. After planting annuals or bulbs, mulch to keep weeds in check. Without mulch, weeds will have to be hoed, resulting in disruption of tree or shrub roots. If not mulched, cultivate lightly—enough to keep the weeds out—or hand pull weeds. One of the best solutions is to place a perennial ground cover that, once established, will choke out potential weeds.



Figure 6.53. Damage to trees from construction and excavation of soil too close to the tree.

Additional irrigation and fertilizer may be needed for young trees or shrubs with competition from ground covers.

Soil grade change. Anytime the soil grade is lowered or raised even a few inches, existing shrubs and trees become predisposed to various stresses. Raising the grade is particularly damaging to woody plants. Normally, the plant is forced to grow a new root system up higher, where oxygen relations are best. Unfortunately, these adventitious root systems are not always formed quickly enough and the tree or shrub dies. Common causes of tree and shrub decline from grade changes are construction and raised flowerbeds around established trees or shrubs (Figure 6.54). Make necessary soil changes as far away from the woody



Figure 6.54. Soil grade change.

plants as possible. Damage can occur far outside the dripline.

Barriers. Construction, such as asphalt paving, can reduce soil oxygen levels by as much as 18 percent. Besides pavement, plastic barriers or black plastic, which have been widely used with various mulch materials, have created problems by reducing gaseous exchange. One improvement is the advent of numerous weed barriers (landscape fabric) that “breathe.”

Secondary effects of oxygen starvation. Sublethal stresses from oxygen deprivation can lead to numerous secondary problems. Disease and insect-related problems resulting from oxygen-induced stresses can decrease leaf production needed for proper root growth. These stresses create a cyclical effect on shoot and root growth, leading to decline and possibly death of the plant. In addition, water and mineral relationships are adversely affected by reduced permeability of roots to water. Hormonal products may also be altered in roots growing with low oxygen conditions. Lastly, excessive moisture resulting in low oxygen may severely hamper effective mycorrhizal colonization. Some tree species need mycorrhizae for effective water and nutrient uptake and utilization.

In many commercial urban areas, the most common cause of trees dying is the pouring of cement around the existing trunks. This can be commonly seen in parking lots and other such areas. The concrete acts as a grade change and prevents the trees’ roots from functioning properly.

Waterlogged soils. Roots in flooded or waterlogged soils often die of oxygen deficiency. Damage occurs not only to plants on obviously wet sites, but also to those in planting holes along city streets and in landscapes where soil drainage is impeded by high clay content. Most trees and shrubs cannot grow for long periods in waterlogged soil, and some die if flooded for only a few days during the growing season.

External symptoms of injury include downward bending of leaf petioles, stem swelling, chlorosis, red or purple pigmentation in leaves, browning of leaf margins, twig dieback, death of roots, wilting, leaf drop and death of the entire plant (Figure 6.55).

Plants with roots injured by waterlogged soil may subsequently suffer drought stress or death when, after the soil drains, the root system is un-



Figure 6.55. Waterlogged soils.

able to meet transpiration demands of the top. This commonly occurs in trees planted in holes in concrete landscapes (parking lots). Plants stressed or injured by waterlogging also become abnormally susceptible to soil-borne pathogens. *Phytophthora* species cause root rot most often in soils that are periodically waterlogged.

The following tree species tolerate waterlogged or flooded soils: birch, button bush, bald cypress, deciduous holly, red maple, native pecan, sweet gum and willow. These tolerant tree species could be planted in soils with poor drainage or areas that tend to flood, but then recede quickly. Also, organic amendments should be incorporated into soils with high clay content to improve the drainage. Do not, however, amend just the planting hole because that will intensify the problem.

Girdling roots

Trees are often stressed or killed by their own roots when they circle around the main trunk and cause girdling (Figure 6.56). Often, strangulation or root girdling leads to the restriction of carbohydrates to the root system, ultimately leading to root starvation. Also, when roots are stressed, they transport less water and nutrients to aboveground portions of the tree, leading to decline in the aboveground portion of the plant as well. Girdling roots slowly weaken trees through a period of several years, where decline can be observed to become worse each growing season. Soil may have to be removed around the trunk's base to find the roots.

Girdling roots are usually found on trees grown in nurseries, but not on those growing naturally in an area. Containerized trees are particularly susceptible to circling roots, which ultimately girdle the plant. If circling roots are not corrected at a



Figure 6.56. Girdling roots.

young age, they will need to be removed with a mallet and chisel or axe later.

Mowers and flexible-line trimmers

Injury and infection started by wounds from lawn mowers and flexible-line trimmers can often be the most serious threat to tree health. Most arborists and tree pathologists have been aware of this problem for some time. Extensive research has been conducted on the importance of caring for tree wounds. This research has led to significant adjustments in pruning, cabling, bracing, injection and cavity treatment. Lawn mowers cause the most severe injury during periods when tree bark is slipping in early spring during leaf emergence and in early fall during leaf drop. If the bark slips, a large wound is produced even when the injury was minor.

Most tree injuries occur when a power mower is used to trim close to tree trunks. This can be avoided by removing turf around trees or by hand trimming. Care must also be used to avoid harm-



Figure 6.57. Lawnmower injury.

ing trees with flexible-line trimmers. They can do a great deal of damage to the bark, particularly on young trees.

Injury usually occurs at the root buttress, since it flares out from the trunk and gets in the path of the mower. However, injury is common anywhere below 1 foot high. Although large wounds are most serious, repeated small wounds also can add up to create problems.

While the wound itself is serious enough, the wounded tree also must protect itself from pathogens invading the wound. These microorganisms often attack the injured bark and invade adjacent healthy tissue, greatly enlarging the affected area. Trees can be completely girdled from microbial attack following lawn mower wounds.

Decay fungi also become active on the wound surface and often result in structural deterioration of the woody tissues beneath the wound. Many wounded trees that are not girdled may eventually break off at the stem or root collar because of internal decay.

Sapsucker damage

The sapsucker is a woodpecker that feeds on tree sap, the inner bark of trees and insects caught in the sap flowing from wounds on the trunk. The most common trees attacked by the sapsucker are apple, birch, magnolia, maple and pines. Sapsuckers peck holes in the bark of trees, causing trees to “bleed” sap. Trees are often repeatedly attacked and on rare occasion may die. The injury also permits insects and diseases to enter the tree. Do not confuse sapsucker damage with bor-er invasion. Sapsucker feeding damage can be identified by evenly spaced rows of holes through the bark on the trunk. These holes are arranged



Figure 6.58. Sapsucker damage.

characteristically in horizontal lines (Figure 6.58) and are sometimes aligned in vertical rows. These birds are protected under federal law, so preventing damage caused by sapsuckers is difficult.

Selecting Plants for the Landscape

The plants listed in Tables 6.5 through 6.9 should help guide the homeowner in making informed plant selections. Not all of the plants listed will necessarily thrive throughout Oklahoma, nor have all been listed which could be grown in various locations within the state. Remember that all plants have inherent problems with various susceptibilities to diseases, insects and environmental stresses. Strive for plant diversity in the home landscape. Try a variety of plants, not only to guarantee survivability of the plantings, but also to increase the diversity, which enhances the aesthetic quality of the landscape.

Table 6.5. Vines/Climbers/Wall Plants for the Landscape*

<i>Scientific Name</i> (Common Name)	<i>Hardiness</i> Zone	<i>Comments</i>
<i>Actinidia arguta</i> (Bower Actinidia, Hardy Kiwi)	3-7	Vigorous, high climbing, twining vine. Flowers delicately fragrant, whitish or greenish white in May to June. Fruit are greenish, yellow berries with lime green flesh. Will tolerate any type of soil. Full sun to partial shade.
<i>A. kolomikta</i> 'Arctic Beauty' (Arctic Beauty, Hardy Kiwi)	4-8	It has variegated pink to green foliage. Other species and cultivars are available as well.
<i>Akebia quinata</i> (Five-Leaf Akebia)	5-9	Interesting "five-leaved," semi-evergreen foliage, climbs by twining. Flowers are rosy purple in late March to early April. Potentially invasive.
<i>Ampelopsis aconitifolia</i> (Monkshood Vine)	4-8	Deciduous vine. Beautiful, deeply cut leaves. Fast-growing vine to 20 feet. Orange-yellow berries in fall. Potentially invasive.
<i>Ampelopsis arborea</i> (Pepper Vine)	7-9	Deciduous vine. Bipinnately compound leaves, four to eight inches long. Fast-growing vine to 30 feet. Dark purple berries in fall, going through the same color transition as porcelain vine. Commonly found throughout Oklahoma. Potentially invasive.
<i>Ampelopsis brevipedunculata</i> (Porcelain Vine, Porcelain Berry)	6-9	Deciduous vine, climbs by tendrils and twining stems. Berries ripen from yellow-green to lavender to turquoise to blue-black in early fall. Potentially invasive.
<i>Ampelopsis cordata</i> (Heartleaf Ampelopsis)	7-9	Deciduous vine, climbs by tendrils and twining stems. Leaves heart-shaped. Fast-growing vine to 48 feet. Berries orange to turquoise-blue in fall. Commonly found throughout Oklahoma. Potentially invasive.
<i>Aristolochia macrophylla</i> (Dutchman's-pipe)	4-8	Vigorous, climbing, twining vine. Ginger-scented brown flowers early fall, full sun, but shade roots, rampant grower. Plant with care.
<i>Bignonia capreolata</i> 'Tangerine Beauty' (Crossvine)	5-9	Semi-evergreen, showy orange flowers, glossy green foliage. Native to North America.
<i>Campsis radicans</i> (Trumpet Creeper)	4-9	Deciduous. Native vine climbs by twining and holdfasts; rampant and suckers. Difficult to eradicate. <i>C x taliabuana</i> 'Madame Galen' is a less aggressive cultivar. Orange flowers, interesting fruits.
<i>Celastrus scandens</i> (American Bittersweet)	3-9	Deciduous, full sun to partial shade. Attractive orange fruit in autumn. Can be rampant. Dioecious plant needing male and female plants in close proximity for good fruit set. Great for floral arrangements. Tolerant of drought and poor soils. Related species include <i>C. loeseneri</i> (loesener bittersweet) with red seed, and <i>C. orbiculatus</i> (chinese bittersweet) both growing 20 to 30 feet.

Table 6.5. Vines/Climbers/Wall Plants for the Landscape* (cont'd)

<i>Scientific Name</i> (Common Name)	<i>Hardiness</i> <i>Zone</i>	<i>Comments</i>
<i>Clematis x jackmanii</i> (Jackman Clematis)	4-8	Deciduous, climbs by twining while leaves clasp or fold over any object, violet-purple flowers from early summer to first frost, many cultivars available. Full sun, but shade roots, rampant grower. Plant with care.
<i>Clematis montana</i> (Anemone Clematis)	5-7	Vigorous almost rampant vine. White to pink flowering species late spring to early summer, several cultivars available.
<i>Clematis orientalis</i> (Oriental Clematis)	6-9	A more restrained clematis to perhaps 10 to 20 feet. Slightly fragrant yellow flowers in late summer, flowers produce a three-inch diameter tuft of glistening feathery achenes.
<i>Clematis tangutica</i> (Golden Clematis)	5-7	Has bright yellow, three to four inches in diameter, campanulate to lantern-shaped flowers in June to July. Seed heads are silky.
<i>Clematis terniflora</i> (Sweet Autumn Clematis)	3-9	Deciduous. Climbs by twining; fragrant white flowers early fall. Full sun, but shade roots, (formerly <i>C. paniculata</i>) rampant grower. Plant with care.
<i>Clematis virginiana</i> (Virgin's Bower, Old Man's Beard)	3-9	Deciduous. Climbs by twining; flowers early fall; and tolerant of full sun, poor soils, and drought.
<i>Euonymus fortunei</i> (Wintercreeper Euonymus)	5-8	Evergreen groundcover or high climbing, true clinging vine. Tolerates full sun and heavy shade. Many cultivars available, including variegated forms. Grows in about any situation except swampy, extremely wet conditions. Scale insects can prove to be a serious problem.
<i>Gelsemium sempervirens</i> (Carolina Yellow Jessamine)	7-10	Evergreen, climbs by twining, medium water; very toxic if eaten. Sun to shade. Often not winter hardy in northern half of Oklahoma.
<i>Hedera helix</i> (English Ivy)	5-9	Evergreen, climbs by holdfasts, shade to part sun, medium water. Can overtake trees. Plant with forethought/caution. Cultivars available.
<i>Hydrangea anomala</i> <i>ssp. petiolaris</i> (Climbing Hydrangea)	4-8	Deciduous; climbs by holdfasts; may need early support. White summer flowers and exfoliating bark on older vines.
<i>Lonicera sempervirens</i> (Trumpet or Coral Honeysuckle)	4-9	Deciduous; possibly semi-evergreen in southeastern Oklahoma. Twining with new growth, reddish purple turning bluish green at maturity. Flowers are non-fragrant and variable in color from orange-red to red on the outside of the tubular corolla, generally yellow to yellow-orange inside. May produce red berries. Prefers moist, well-drained, acid or near neutral soils.
<i>Parthenocissus quinquefolia</i> (Virginia Creeper)	4-9	Deciduous, climbs by adhesive discs. Nice fall color. Showy purple fruits. Grows in sun or shade.

Table 6.5. Vines/Climbers/Wall Plants for the Landscape* (cont'd)

<i>Scientific Name</i> (<i>Common Name</i>)	<i>Hardiness</i> <i>Zone</i>	<i>Comments</i>
<i>Parthenocissus tricuspidata</i> (Boston Ivy)	4-9	Deciduous, climbs by adhesive discs. Leaves are brilliant red in fall. Grows in sun or shade.
<i>Passiflora incarnata</i> (Passionflower Vine)	6-8	Native throughout Oklahoma except in southwest and panhandle. Produces large, interesting flowers that are white to deep purple. Fruits are edible.
<i>Periploca graeca</i> (Grecian Silkvine)	5-9	Deciduous, tolerant of most soils, low water, and sun. Provides fast cover.
<i>Polygonum aubertii</i> (Silver Lace Vine, Silver Fleeceflower)	4-7	Deciduous, climbs by twining, white flowers, rampant, tolerant of low water.
<i>Rosa</i> spp. (Climbing Rose)	4-9	Available in a variety of colors, longed lived plants.
<i>Vitis</i> spp. (Grape)	6-10	Deciduous, climbs by tendrils. Showy edible fruits. Red, yellow, purple fall color.
<i>Wisteria floribunda</i> (Japanese Wisteria)	4-9	Deciduous, climbs by twining. Vigorous grower, medium water, more cold tolerant than Chinese wisteria.
<i>Wisteria sinensis</i> (Chinese Wisteria)	5-9	Deciduous, climbs by twining. Vigorous grower, medium water. Purple and white cultivars.
<i>Wisteria frutescens</i> (American Wisteria)	5-9	Native deciduous vine. Not as vigorous as Chinese and Japanese species. Dear tolerant. Tolerates moist soils. Lilac-purple flowers in spring.

* Many varieties and cultivars of vines and plants with related growth habits exist that are not listed. For the sake of brevity, only one or two samples are provided for any given group of plants. For example, there are numerous variations or cultivars of passiflora and its hybrids selected for flower color, hardiness, etc.

Tree Selection Guide

Mature height (**MHt**) will vary considerably by cultivar and site and is shown here assuming adequate care: **Low**: <20 feet; **Medium**: 20 to 40 feet; and **High**: >40 feet.

Growth rate (**GR**) refers to height growth for the first 10 years after a tree is planted and is shown as follows: **Low**: <12 inches per year; **Medium**: 12 to 24 inches per year; and **High**: >24 inches per year.

Region refers to the area of Oklahoma in which the plant grows best.

P - Panhandle

NW - Northwest

SW - Southwest

NE - Northeast

SE - Southeast

A - all regions

See Table 6.6

Selecting Shrubs for the Landscape

Shrubs serve an important role in landscaping. They can be used as hedge borders, focal points, along the foundation of a home to “tie” it to the ground by softening strong architectural lines, and to fill large areas. Shrubs screen and separate private areas, create garden rooms and absorb noise. Many are evergreen, providing a backbone for the winter landscape (Table 6.7).

Unlike annual flowers or even some herbaceous perennials, shrubs are usually planted with permanence in mind. As such, it is important to carefully select plants to ensure long-term success. It is important to consider the plant’s adaptability to the proposed planting site as well as its mature size. For best results, choose a plant best adapted to the climatic zone or region and will fit in the space designated for planting even after it reaches full size.

When selecting shrubs for the landscape, it also is important to consider each plant’s ornamental characteristics. Consider plant height, width and shape; foliage color and texture, including that in the fall; bark attributes; and flowering and fruiting habits to obtain the right shrub for your landscape design.

Ornamental Characteristics of Shrubs

Many shrubs are planted for their showy floral displays. A long season of bloom can be obtained by planting various types of shrubs. The time any shrub remains in bloom varies from a few days to a few months, however, the time of year a shrub blooms remains the same year after year. Use a variety of shrubs that bloom in sequence to develop a planting with a long blooming period. Most landscapes have lots of flowers in spring, with few in summer or fall. Prolong the ornamental season through careful shrub selection. Choose shrubs known to bloom at alternate times of year or choose plants that provide other ornamental traits during hot weather and into the fall such as colorful bark, fall foliage or fruit.

A number of ornamental shrubs produce attractive fruits after flowering. Some have black or dark purple fruit that often go unnoticed unless sited for contrast. Brightly colored fruit make a better show than dull colors. The time fruit is ornamental should be a consideration. Fruit persisting into winter provides color in the winter landscape. A shrub may produce beautiful fruit, but too few to be noticed, so their ornamental value is low. Within limits, the larger the fruit the more ornamental it may be. Conversely, large fruit can be a problem to clean up.

For shrubs such as holly and yew, male and female flowers are produced on separate plants and fruit is only produced on the female plants. A plant with this flowering and fruiting habit is called dioecious. When female, fruiting plants are desired, a male plant must also be grown to ensure pollination. Usually one male shrub pollinates several female plants.

Foliage color, other than green, can occur in fall, in spring or from spring to fall. Spring only foliage color fades to green or off green by summer. Colored foliage or variegated shrubs can be less vigorous than the same plant with green foliage. Shrubs with colored or variegated foliage may need different light intensity. Sunlight is often necessary for good fall color development or summer foliage coloration. For example, barberry cultivars with purple leaves in the sun may have nearly green leaves in the shade.

Bark is another ornamental feature. The bark may be highly colored or have interesting texture. Shrubs with evergreen foliage, brightly colored

and/or striking bark textures and patterns also can provide winter color and interest.

Attracting wildlife may be a reason for selecting a particular shrub. Some shrubs produce fruits eaten by birds, others provide shelter and some yield flowers that attract butterflies.

Some shrubs have safety concerns to consider. Don't plant shrubs with poisonous berries near public walkways. Plants with poisonous parts or spiny foliage or stems should be avoided in high traffic areas. On the other hand, spiny shrubs/hedges may provide "traffic control" and security for an area.

Select shrubs hardy enough to survive the winter and durable enough to endure the Oklahoma summer heat.

Avoid shrubs with serious pest problems. The large selection of available shrubs makes it unnecessary to use those notorious for annual infestations of insects or diseases. Pests attack most shrubs at some point during their lives, but most can be easily controlled or ignored. Shrubs to avoid are those with annual serious pest problems that last long periods of time and render the plant aesthetically unacceptable.

Table 6.6. Deciduous Trees.

<i>Broadleaves (mostly deciduous)</i>	<i>Region</i>	<i>GR</i>	<i>MHt</i>	<i>Comments</i>
Ash, Green (<i>Fraxinus pennsylvanica</i>)	A	H	H	Grows well in a variety of soils. Good fall color. Borers may be a problem.
Ash, White (<i>Fraxinus americana</i>)	A	M	M	Not as adaptable to various soils as green ash. Needs well-drained soil. Borers may be a problem.
Beech, American (<i>Fagus grandifolia</i>)	NE, SE	L	H	Beautiful tree in spring and summer. Prefers moist, well-drained, sandy soils.
Birch, River (<i>Betula nigra</i>)	NE, SE NW, SW	H	H	Less susceptible to borers. Thrives in moist soils of various textures. Leaves may turn yellow and drop during the heat of the summer. Best birch for Oklahoma.
Buckeye, Red (<i>Aesculus glabra</i> ssp. <i>pavia</i>)	NE, SE	M	M	Grows best in deep, rich, well-drained, moist, sandy loam soils. Leaf scorch as well as some diseases and insects can be a problem if not grown in ideal conditions. Provide partial shade.
Buckthorn, Carolina or Indiancherry (<i>Rhamnus carolinianus</i>)	A	M	S	Oklahoma Proven Selection.
Catalpa, Southern (<i>Catalpa bignonioides</i>)	A	M	M	Will grow in just about any soil. Flowers in spring are quite showy. Tree is rather weak wooded and messy.
Chestnut, Chinese (<i>Castanea mollissima</i>)	NE, SE	M	L	Prefers full sun and reasonably well-drained soil. Drought tolerant. Edible fruit.
Chittimwood (<i>Bumelia lanuginosa</i>)	A	L	M	Underutilized native, adaptable, drought tolerant tree.
Coffeetree, Kentucky (<i>Gymnocladus dioicus</i>)	A	M	H	Prefers deep, rich, moist, sandy loam soils, but very tolerant of a wide range of soil conditions and drought. Attractive, open, loose structure. Few problems. Female trees produce bean pods; male selections like 'Espresso' are available. Oklahoma Proven Selection.
Cottonwood, Eastern (<i>Populus deltoides</i>)	A	H	H	Tolerant of dry, less favorable sites. Best used in large open areas, grows too big for a typical landscape. Over time roots grow on the surface. Fast growing, weak wooded, messy, and susceptible to diseases and insects. Choose cottonless male cultivar when possible.
Crabapple, Flowering (<i>Malus</i> spp.)	A	M	L	Excellent spring flower. Attractive fruit. Tolerant of most soil conditions. Choose disease resistant varieties. 'Prairiefire' - Oklahoma Proven Selection.
Crapemyrtle, Common (<i>Lagerstroemia indica</i>)	NE, SE, NW, SW	M	L	Very adaptable. Excellent summer flowers, fall color; some have great bark color and texture. Select mildew resistant varieties.

Table 6.6. Deciduous Trees (cont'd).

<i>Broadleaves (mostly deciduous)</i>	<i>Region</i>	<i>GR</i>	<i>MHt</i>	<i>Comments</i>
Cypress, Bald (<i>Taxodium distichum</i>)	A	M	H	Wonderful fern-like foliage and strong, pyramidal form. Found in swampy conditions, but is very drought tolerant and grows in many soils. No serious pest problems. May become chlorotic in highly alkaline soils. Oklahoma Proven Selection.
Cypress, Pond (<i>Taxodium ascendens</i>)	A	M	H	Similar to bald cypress, but more narrow in habitat and have needle-like leaves.
Dawn Redwood (<i>Metasequoia glyptostroboides</i>)	NE, SE NW, SW	H	H	Prefers moist, deep, well-drained, slightly acid soils. Best suited for large areas.
Desert-Willow (<i>Chilopsis linearis</i>)	A	M	M	Loose, gangly in appearance. Requires well-drained, dry soils. Pink, purple, or white flowers in summer.
Dogwood, Cornelian Cherry (<i>Cornus mas</i>)	A	M	M	Flowers are yellow in small clusters. Bright red edible fruit in mid-summer. More tolerant of soil conditions than flowering dogwood. Attractive bark with age.
Dogwood, Flowering (<i>Cornus florida</i>)	NE, SE	L	L	Grows best in areas with partial shade and protected from hot dry winds. Prefers rich, well-drained, acid soils.
Dogwood, Kousa (<i>Cornus kousa</i>)	NE, SE	L	M	Needs well-drained, acid soils. Sun to part shade. Spring flower and attractive fruit in late summer/fall. Good fall leaf color.
Elm, American (<i>Ulmus americana</i>)	A	H	H	Select Dutch elm disease resistant varieties/hybrids, Oklahoma Proven Selection - Collector's Choice.
Elm, Lacebark or Chinese (<i>Ulmus parvifolia</i>)	A	M	H	Exfoliating, multi-colored bark. Extremely tough and drought tolerant. Golden form available.
Elm, Cedar (<i>Ulmus crassifolia</i>)	A	M	H	Prefers well-drained, moist areas, but is tolerant of less favorable soil sites. Attractive native elm that produces a corky wing-like extension along sides of branchlets. Oklahoma Proven Selection.
Euonymus, Pink Lady Winterberry (<i>Euonymus bungeanus</i> 'Pink Lady')	A	M	L	Attractive pink fruit that open exposing a white or pinkish seed with an orange aril. Occasionally contracts scale insects.
Fig, Common (<i>Ficus carica</i>)	NE, SE NW, SW	H	L	Easy to grow and tolerates a wide range of soil conditions. Needs protection during winter in the northern portions of Oklahoma. Grow for novelty and edible fruit.
Fringetree, White (<i>Chionanthus virginicus</i>)	NE, SE	L	L	Excellent specimen tree with white, fragrant flowers appearing in spring, and a nice yellow, fall color. Should be planted in soils that are fertile, moist, and well-drained. Will not tolerate windy, exposed or harsh conditions.

Table 6.6. Deciduous Trees (cont'd).

<i>Broadleaves (mostly deciduous)</i>	<i>Region</i>	<i>GR</i>	<i>MHt</i>	<i>Comments</i>
Ginkgo (<i>Ginkgo biloba</i>)	NE, SE	M	H	Unique fan-shaped leaves medium to dark green in summer turning golden-yellow in fall. Tolerant of soil conditions and excellent for urban conditions. Usually slow rate of growth in Oklahoma. Male trees should be used to avoid foul smelling fruits.
Goldenraintree (<i>Koelreuteria paniculata</i>)	A	M	M	Bright yellow panicles of flowers appear in June to July. Papery fruit capsules can be rather showy. Very adaptable small tree that grows well in a variety of soils and conditions. Drought tolerant. Red-shoulder bugs may be a nuisance to the homeowner.
Hackberry (<i>Celtis occidentalis</i>)	A	H	H	Small, purple to black fruits appear in fall and are relished by birds and wildlife. Yellow fall color. Grows in about any soil type imaginable. Hackberry nipple gall insects can lessen overall appearance.
Hackberry, Southern or Sugarberry (<i>Celtis laevigata</i>)	NE, SE NW, SW	H	H	Good tree for urban situations. Fruit relished by birds.
Hawthorn, English (<i>Crataegus laevigata</i>)	A	M	L	Grows just about anywhere and shows a great degree of drought tolerance. Spring flowers, with colorful fruit in fall. Good fall color. Cedar hawthorn rust and fireblight may be problems along with borers and spider mites.
Hawthorn, Washington (<i>Crataegus phaenopyrum</i>)	A	M	L	Spring flowers; attractive summer and fall foliage color; attractive fruit. Cedar hawthorn rust, on occasion, usually lessens aesthetic value.
Holly, Possumhaw or Deciduous (<i>Ilex decidua</i>)	A	M	L	Excellent fall/winter berries. Tolerates a wide variety of soil conditions.
Hophornbeam, American, Ironwood (<i>Ostrya virginiana</i>)	NE, SE	L	M	Rugged, dependable, disease and insect resistant tree.
Hornbeam, American (<i>Carpinus caroliniana</i>)	NE, SE NW, SW	L	M	Will tolerate shade, and often found as an understory plant.
Japanese Pagodatree, Scholar- tree (<i>Styphnolobium japonicum</i>)	NE, SE NW, SW	M	M	Fragrant, creamy white blooms in mid-summer. Showy winter fruits. Withstands heat and drought well. Some canker problems may occur resulting in slight limb dieback.
Jujube or False Date (<i>Ziziphus jujuba</i>)	A	M	L	Will tolerate just about any soil except poorly drained soil. Date-like fruit are slightly sweet and edible. Great as an accent, specimen plant, or shade tree.

Table 6.6. Deciduous Trees (cont'd).

<i>Broadleaves (mostly deciduous)</i>	<i>Region</i>	<i>GR</i>	<i>MHt</i>	<i>Comments</i>
Katsuratree (<i>Cercidiphyllum japonicum</i>)	NE, SE	M	L	Good for small residential properties. Foliage emerges with a reddish-purple tint, changing a bluish-green by mid-summer, and then a yellow to yellow-orange in fall. Marginally drought tolerant. May be subject to scorch and other stresses due to the Oklahoma heat. Sometimes challenging to grow.
Lilac, Japanese Tree (<i>Syringa reticulata</i>)	A	M	L	Creamy white, fragrant flowers appear in early summer. Tolerates Oklahoma heat. Resistant to mildew, scale, and borer.
Linden, American or American Basswood (<i>Tilia americana</i>)	A	M	H	Good shade or street tree. Adaptable and tolerant of drier, harsher landscape sites. Bees are attracted to flowers in spring. Occasional pests.
Linden, Crimean (<i>Tilia x euchlora</i>)	A	M	H	Graceful in habit with lower branches skirting the ground. Leaves dark lustrous green. May be less susceptible to aphids. Can develop basal suckers on grafted forms.
Linden, Littleleaf European (<i>Tilia cordata</i>)	A	M	M	Very attractive tree forming a densely pyramidal shape. Good tree for urban situations. Drought tolerant, however, may lose considerable leaves during severe stress.
Linden, Silver (<i>Tilia tomentosa</i>)	A	M	H	Good street tree that tolerates heat and drought better than the other lindens. Oklahoma Proven Selection.
Magnolia, Saucer (<i>Magnolia x soulangiana</i>)	A	M	M	Beautiful, large flowers appearing before leaves in early spring. Many cultivars available. Mulch to conserve moisture and maintain slightly acidic pH. Excellent specimen tree. Flowers are sometimes killed by late frosts. Locate plant on the north or east side of a building to reduce early development of flowers that may be damaged by late frosts.
Magnolia, Star (<i>Magnolia stellata</i>)	A	L	L	White, slightly fragrant, flowers appear early spring before leaves appear. Cultural comments are same as saucer magnolia.
Maple, Amur or Ginnala (<i>Acer tataricum</i> ssp. <i>ginnala</i>)	A	M	L	Excellent small tree, usually multi-stemmed. Brown to red, winged, fruit mature in late summer early fall. May have fall color of shades of yellow and red. Chlorosis in high pH soils.
Maple, Hedge (<i>Acer campestre</i>)	A	M	M	Urban tolerant. Excellent small tree.
Maple, Japanese (<i>Acer palmatum</i>)	NE, SE NW, SW	L	L	Should be protected from hot dry winds and late afternoon sun. Many cultivars and varieties available. Prefers deep, rich, slightly acid soils. Slow growing.

Table 6.6. Deciduous Trees (cont'd).

<i>Broadleaves (mostly deciduous)</i>	<i>Region</i>	<i>GR</i>	<i>MHt</i>	<i>Comments</i>
Maple, Paperbark (<i>Acer griseum</i>)	NE, SE	L	M	Adaptable to a variety of soils. Performs well in clay soils. Good fall color. Good specimen tree. Provides partial shade.
Maple, Purpleblow or Shantung Maple (<i>Acer truncatum</i>)	NE, SE, NW, SW	L	M	Leaves are reddish purple when emerging, changing to dark glossy green. Good fall color. Very drought tolerant. Good urban tree resistant to leaf scorch. Oklahoma Proven Selection.
Maple, Red (<i>Acer rubrum</i>)	NE, SE	M	H	Fairly tolerant of soil conditions, but not particularly drought tolerant. Leaf scorch is common when planted in dry, rocky soils. Prefers moist, slightly acid conditions. Excellent fall color. Many cultivars available. Chlorosis can be a problem in western Oklahoma.
Maple, Silver (<i>Acer saccharinum</i>)	A	H	H	Shallow root system that can invade flowerbeds. Fast growing. This results in weak, brittle wood. Very tolerant of poor growing conditions.
Maple, Sugar (<i>Acer saccharum</i>)	A	M	H	Large tree with brilliant fall color. Slower growing than most other maples. Best adapted to deep, rich, moist, sandy loam soils. Caddo sugar maple is native to west-central Oklahoma making it suitable for most regions of the state. Caddo is more resistant to leaf scorch. Oklahoma Proven Selection - Collector's Choice.
Maple, Tatarian (<i>Acer tataricum</i>)	NW, SW	M	M	Excellent small tree similar to amur maple. Good for residential landscape, street tree use, and perhaps planter boxes. Tolerant of adverse conditions including drought.
Maple, Trident (<i>Acer buergeranum</i>)	NE, SE NW, SW	L	M	Well-drained, acid soils. Good drought resistance. Leaves emerge rich bronze to purple, maturing to glossy dark green. Handsome small tree.
Mulberry, White (<i>Morus alba</i>) (fruitless)	A	H	H	Choose a fruitless variety to avoid the messy fruit. Not generally recommended except for the harshest landscape conditions. Weeping cultivars available.
Oak, Bur (<i>Quercus macrocarpa</i>)	A	M	H	Slow growing, eventually becomes very large. Perhaps too big for the average-sized landscape. However, very tolerant of many soil conditions, even dry, clay soils. Very tolerant of city conditions. Oklahoma Proven Selection.
Oak, Chinkapin (<i>Quercus muehlenbergii</i>)	A	M	H	Drought tolerant. In wild grows on dry limestone outcrops with alkaline reaction; prefers and grows largest in rich, bottomland soils.

Table 6.6. Deciduous Trees (cont'd).

<i>Broadleaves (mostly deciduous)</i>	<i>Region</i>	<i>GR</i>	<i>MHt</i>	<i>Comments</i>
Oak, English (<i>Quercus robur</i>)	A	M	H	Prefers well-drained soil, pH tolerant, full sun. Powdery mildew and scale can sometimes be a problem.
Oak, Live (<i>Quercus virginiana</i>)	NE, SE SW	M	M	Not cold hardy in most of Oklahoma. Best grown in the extreme southern regions of the state. Look for selections for the western part of the state.
Oak, Northern Red (<i>Quercus rubra</i>)	A	M	H	Prefers moist, rich soils, but adapts well to less hospitable soil sites.
Oak, Pin (<i>Quercus palustris</i>)	NE, SE	H	H	Develops iron chlorosis in alkaline soils.
Oak, Sawtooth (<i>Quercus acutissima</i>)	NE, SE NW, SW	M	H	Leaves open a brilliant yellow to golden yellow in spring turning a dark lustrous green in summer. Quite adaptable to soils, may develop chlorosis in high pH soils. Subject to ice damage.
Oak, Scarlet (<i>Quercus coccinea</i>)	A	M	H	Similar to pin oak, but may be found on dry, sandy sites. Subject to, but does not develop chlorosis to the degree of pin oak.
Oak, Shingle (<i>Quercus imbricaria</i>)	NE, SE	M	H	Prefers moist, rich, deep, well-drained, acid soils although tolerates drier soils.
Oak, Shumard (<i>Quercus shumardii</i>)	A	M	H	Excellent tree for Oklahoma. Oklahoma Proven Selection.
Oak, Swamp White (<i>Quercus bicolor</i>)	NE, SE	M	H	Will grow in swampy areas. Also drought tolerant. Requires neutral to acidic soil.
Oak, Water (<i>Quercus nigra</i>)	NE, SE	H	H	Moisture loving, bottomland tree, native to wetlands. Semi-evergreen foliage. Fast growing.
Oak, White (<i>Quercus alba</i>)	NE, SE	M	H	Slow grower, becoming very large with age. Brilliant fall color. Prefers rich, moist, acid soils. Chlorosis occurs in high pH soils.
Oak, Willow (<i>Quercus phellos</i>)	NE, SE	M	H	Good yellow fall color. Fast growing. Needs moist, acid soil conditions for best growth. Chlorosis in high pH soils.
Orange, Trifoliolate (<i>Poncirus trifoliata</i>)	NE, SE	L	L	White citrus-like spring flowers, very fragrant. Edible fruit. Dark green trifoliolate leaves that turn yellow in fall. Grows in a wide range of soil conditions. Used primarily as a hedge or small tree. Produces thorns.
Osage-orange (<i>Maclura pomifera</i>) 'Whiteshield'	A	M	M	Will grow anywhere and is extremely drought tolerant. Choose male cultivars such as 'Whiteshield' to alleviate the problem of large messy fruits and thorns.
Parrotia, Persian (<i>Parrotia persica</i>)	A	M	M	Oklahoma Proven Selection - Collector's Choice.
Pawpaw (<i>Asimina triloba</i>)	NE, SE	M	L	Nodding purple flowers appearing before leaves emerge. Edible fruit. Used primarily as a novelty plant. Provide shade for best growth.

Table 6.6. Deciduous Trees (cont'd).

<i>Broadleaves (mostly deciduous)</i>	<i>Region</i>	<i>GR</i>	<i>MHt</i>	<i>Comments</i>
Pear, Callery (<i>Pyrus calleryana</i>) (Aristocrat, Chanticleer, Whitehouse, Capital)	A	M	M	Very tolerant of soil types and drought conditions. Spring flowers, good fall color. Best to choose cultivars that develop better branching structure than Bradford.
Pecan (<i>Carya illinoensis</i>)	A	H	H	Native to deep, rich, moist, well-drained soils. Not a good tree for poor soils. Provides excellent shade, but will often drop large limbs as it becomes older. Will usually produce nuts that are edible, but some consider them messy. Subject to many pests.
Persimmon, Common (<i>Diospyros virginiana</i>)	NE, SE, NW, SW	L	M	Edible fruit. Prefers moist, well-drained, sandy soils, but will do well on low fertility and dry soils; pH adaptable. Will sucker, forming thickets. Wildlife attracted to fruit. More of a novelty type plant. Attractive alligator hide bark. Webworms or tent caterpillars can be pests.
Persimmon, Japanese (<i>Diospyros kaki</i>)	NE, SE	L	M	Tolerant of soil conditions except poorly drained soil. Large colorful fruit and excellent fall color. More of a novelty plant. Check with a grower for most cold hardy selections.
Pistache, Chinese (<i>Pistacia chinensis</i>)	A	M	M	Widely adaptable. Excellent urban tree. Brilliant fall color. Oklahoma Proven Selection.
Planetree, London (<i>Platanus x acerifolia</i>)	A	H	H	Excellent bark color and texture. Good tree for large areas. Grows just about anywhere. More resistant to anthracnose than sycamore. Other diseases and insect problems may occur.
Plum, Mexican (<i>Prunus mexicana</i>)	A	M	L	Interesting bark, white flower in spring and colorful purplish red fruit in late summer. Adaptable to various soil conditions, quite drought tolerant. Native to central and eastern Oklahoma.
Plum, Purpleleaf (<i>Prunus cerasifera</i>)	A	M	L	Does not grow well in heavy clay soils and are often prone to borers and leaf eating insects. Short-lived tree. Good purplish leaf color, white to pink spring flowers.
Poplar, White (<i>Populus alba</i>)	A	H	H	Extremely tolerant of soil conditions. Surface roots. Many disease and insect problems. Weak wooded. Attractive, but inferior tree.
Redbud, Eastern (<i>Cercis canadensis</i>)	A	M	L	Oklahoma state tree. Not finicky of growing conditions. Full sun to part shade. Showy clusters of flowers appearing before leaves in spring. Flower color purplish in color or white.

Table 6.6. Deciduous Trees (cont'd).

<i>Broadleaves (mostly deciduous)</i>	<i>Region</i>	<i>GR</i>	<i>MHt</i>	<i>Comments</i>
Redbud, Oklahoma (<i>Cercis canadensis</i> var. <i>texensis</i> 'Oklahoma')	NE, SE, NW, SW	M	L	Similar to eastern redbud except leaves are thick, lustrous, shiny, and dark green. Compact 10 to 12 foot at maturity. Flowers deep purple. Oklahoma Proven Selection.
Sassafras (<i>Sassafras albidum</i>)	NE, SE	M	H	Outstanding native tree for fall color. Yellow flowers appear early spring before foliage. Excellent for naturalized settings. Needs moist, loamy, well-drained, acid soils. Develops chlorosis in high pH soils.
Serviceberry (<i>Amelanchier arborea</i>)	A	L	L	White showy spring flowers. Small, round, dark purple fruit. Colorful fall foliage. Good as small specimen tree or naturalized landscape plant.
Serviceberry, Saskatoon (<i>Amelanchier alnifolia</i>)	A	L	L	Bluish-purple berries that ripen in mid-summer are edible. Tolerates harsh climate and alkaline soil.
Silverbell, Carolina (<i>Halesia tetraptera</i>)	NE, SE	M	M	Bell-shaped, white flowers in spring. Showy winged fruit. Prefers rich, well-drained, moist, slightly acid soils high in organic matter. Very effective as a specimen plant. Provide light shade.
Smoketree, American (<i>Cotinus obovatus</i>)	NE, SE, NW, SW	M	M	Bluish to dark green summer foliage with magnificent fall color. Well adapted to limestone soils. Native to Oklahoma.
Smoketree, Common (<i>Cotinus coggyria</i>)	A	M	L	Produces large, loose terminal panicles of pinkish flowers in late May and June, somewhat feathery and delicate in appearance. Foliage color variable depending on cultivar from green to purple. Fall color is orange to red. Tough, adaptable, and drought tolerant.
Soapberry (<i>Sapindus drummondii</i>)	A	M	M	Very drought tolerant and tolerant of a variety of poor, dry soil sites. Leaves turn golden yellow in fall. Small yellow-orange fruit. Red shoulder bugs seem to be attracted to this tree and can be a nuisance.
Sourgum, Black (<i>Nyssa sylvatica</i>)	NE, SE	L	H	Brilliant fall color. Does very well on rich, moist, well-drained sites, but is tolerant of less favorable sites.
Sourwood (<i>Oxydendrum arboreum</i>)	NE, SE	L	M	Good summer foliage color and excellent fall color. White fragrant flower in early summer. Grows in peaty, moist, well-drained, acid soils. Not good for urban sites; challenging to grow.

Table 6.6. Deciduous Trees (cont'd).

<i>Broadleaves (mostly deciduous)</i>	<i>Region</i>	<i>GR</i>	<i>MHt</i>	<i>Comments</i>
Sweetgum, American (<i>Liquidambar styraciflua</i>)	NE, SE, NW, SW	M	H	Grow Rotundiloba or Cherokee - sterile selections. Excellent fall color. Thrives in damp, moist, rich, well-drained soils. Not as tolerant to drought or drier, upland sites. May develop shallow root system; may develop iron chlorosis in high pH soils, particularly in western Oklahoma. Easiest to grow in eastern half of the state.
Sycamore, American (<i>Platanus occidentalis</i>)	A	H	H	Large tree and should be used in large open areas. Anthracnose is most common problem. Adapted to a wide range of soil conditions. Can be messy dropping fruit, leaves, twigs, and bark nearly year round.
Vitex, Chastetree (<i>Vitex negundo</i>)	A	H	L	Produces blue-purple, lilac, or lavender flowers in mid-summer. May freeze back, but will come back from roots.
Walnut, Black (<i>Juglans nigra</i>)	A	M	H	Thrives in deep, rich, moist soils, tolerates drier soils. Large shade tree.
Willow, Corkscrew (<i>Salix matsudana</i> 'Tortuosa')	A	H	M	Fast growing and like any other willow is susceptible to many diseases and insects. This tree has uniquely twisted branches that are used in floral arrangements.
Willow, Weeping (<i>Salix babylonica</i>)	A	H	H	Grows best in moist to wet soils. Susceptible to many disease and insect problems especially when stressed.
Witchhazel (<i>Hamamelis virginiana</i>)	NE, SE, NW, SW	M	L	Yellow, fragrant flowers appear in winter. Prefers a moist soil and partial shade; avoid extremely dry areas. Yellow fall color.
Yellowwood (<i>Cladrastis kentukea</i>)	NE, SE	M	H	White, fragrant flowers on pendulous terminal panicles in spring. Spring foliage has yellowish-green color turning to bright green in summer. Yellow to golden yellow in fall. Attractive smooth gray bark. Prefers deep, fertile, moist, sandy loam soils and is pH adaptable. Shows some degree of drought tolerance.
Yellow-poplar or Tuliptree (<i>Liriodendron tulipifera</i>)	NE, SE	H	H	Produces a tulip-like flower in spring, usually high in the tree so it often goes unnoticed. Best for large and open landscapes.
Zelkova, Japanese (<i>Zelkova serrata</i>)	A	H	H	Elm relative with similar characteristics, thus sometimes planted as replacement for American elm. Dutch elm disease resistant. Once established is very wind and drought tolerant; pH adaptable. Good for streets and urban areas. Subject to elm leaf beetle feeding damage. Several cultivars and related species available.

Table 6.7. Evergreen Trees.
Needle, scale and broadleaf evergreens.

	<i>Region</i>	<i>GR</i>	<i>MHt</i>	<i>Comments</i>
Arborvitae, American or Eastern (<i>Thuja occidentalis</i>)	A	M	M	Numerous cultivars available. Should be planted in deep, well-drained soil; once established will tolerate heat and drought. Susceptible to strong winds, ice and snow. Good for hedges, screens, specimen.
Arborvitae, Oriental (<i>Platyclusus orientalis</i>)	A	L	M	Tolerant of most soils except those that are extremely wet; pH adaptable. Good for hedges and specimens. Many cultivars.
Cedar, Atlas (<i>Cedrus atlantica</i>)	A	M	H	Primarily used as a specimen tree. Good substitute for Colorado spruce. Blue and weeping forms available.
Cedar, Deodar (<i>Cedrus deodara</i>)	NE, SE	M	H	Less cold hardy than atlas cedar. Full sun, should be protected from sweeping winds. Moderate degree of drought tolerance.
Cedar, Western Red, giant Arbrovitae (<i>Thuja plicata</i>)	NE, SE, C	S-M	H	Prefers moist, well-drained, fertile soils. In wild grows near rivers and swamps, even found in bogs; pH adaptable. Growth will be stunted on dry soils.
California Incense Cedar (<i>Calocedrus decurrens</i>)	NE, SE, C, NW, SW	S-M	H	Prefers moist, well-drained, fertile soil; but it shows good adaptability to different soil types, tolerates poor soils. Very drought and heat tolerant when established. Not tolerant of wind-swept areas. Handsome specimen for large areas.
Cherry Laurel (<i>Prunus caroliniana</i>)	A	H	M	Good for screens, background plant and as small patio tree.
China Fir (<i>Cunninghamia lanceolata</i>)	NE, SE	L	H	Prefers, moist, acid, well-drained soils. Grows best in open spaces shaded by trees and protected from windswept sites.
Cypress, Alaska or Nootka (<i>Chamaecyparis nootkatensis</i>)	NE, SE, C, NW	M	H	Bagworms and mites can be problems. Full sun. Avoid southwest Oklahoma.
Cypress, Arizona (<i>Cupressus arizonica</i>)	NE, SE, C, NW, SW	M	H	Will grow well as far north as Woodward. Full sun.
Cypress, Hinoki False (<i>Chamaecyparis obtusa</i>)	NE, SE, C	M	H	Shelter from hot wind and afternoon sun.
Cypress, Italian (<i>Cupressus sempervirens</i>)	SE	M	M	Columnar 30' tall by 2' wide. Bagworms and mites. Sun to part shade.
Cypress, Japanese False (<i>Chamaecyparis pisifera</i>)	NE, SE, C	M	H	Loam soils. Part sun. Shelter from hot wind and afternoon sun.
Cypress, Leyland (<i>X Cupressocyparis leylandii</i>)	SE, C	H	H	Loam to clay loam. Feathery foliage. Grows to 50' tall and 30' wide.
Holly, American (<i>Ilex opaca</i>)	NE, SE, C	L	M	Well-drained, acid soils. Sun to part shade. Leaves have spines. Foliage is not glossy. Medium drought tolerance, mulch. Much variation by species and cultivars. Most are tree-like from 20-30' tall by 12-20' wide.

Table 6.7. Evergreen Trees (cont'd).

	<i>Region</i>	<i>GR</i>	<i>MHt</i>	<i>Comments</i>
Juniper, Eastern Red Cedar (<i>Juniperus virginiana</i>)	A	M	M	Has become a weed for ranchers, but makes good windbreak. Many cultivars to choose from. Co-host for Cedar-Apple Rust disease.
*Juniper, Rocky Mountain (<i>Juniperus scopulorum</i>)	P, NW, SW	M	M	Susceptible to phomopsis blight east of I-35 highway. Many cultivars.
Magnolia, Southern (<i>Magnolia grandiflora</i>)	NE, SE, C	M	M	Grow to 50 to 60 feet tall and 30 to 50 feet wide. Should be given adequate space for growth. Large white fragrant flowers. Avoid hot dry windy sites. Mulch, water and fertilize. Not drought tolerant. Remove narrow forks, but don't over prune.
Myrtle, Wax (<i>Myrica cerifera</i>)	NE, SE, C	H	L	Thrives in full sun to part shade. Tolerates wide range of soil conditions and seems to tolerate poorly drained soils.
Pine, Austrian (<i>Pinus nigra</i>)	A	M	H	One of the most pest free, but can be affected by Diplodia Tip Blight and the devastating Pine Wood Nematode disease. Very drought tolerant. Full sun. Well to moderately drained soil.
Pine, Eastern White (<i>Pinus strobus</i>)	NE, SE	H	H	Loam soil. Protect from hot wind and drought. Soft needles. Full sun to part shade.
Pine, Japanese Black (<i>Pinus thunbergiana</i>)	NE, SE, C, SW	M	M	Looks like Austrian pine. Loam to clay. Tolerates salty soils. Very susceptible to Pine Wood Nematode.
Pine, Japanese Red (<i>Pinus densiflora</i>)	A	M	H	Sun to part shade. Loam to clay loam. Many stems, orange with age. Shelter from cold northwest winter wind. Very susceptible to Pine Wood Nematode.
Pine, Lacebark (<i>Pinus bungeana</i>)	A	L	H	Prefers well-drained soil in sunny location. Interesting exfoliating bark.
Pine, Limber (<i>Pinus flexilis</i>)	A	L	M	Better north than south. Nematode resistant. Well-drained moist soil. Flexible limbs. Five needled tree.
Pine, Loblolly (<i>Pinus taeda</i>)	NE, SE, C, W	H	H	Loam to clay loam. Sun to part shade. Southeast U.S. forest pine, thus do not make suitable specimen or windbreak plants. Pine Tip moth a problem when young.
Pine, Mugo (<i>Pinus mugo</i>)	A	L	L	Loam to clay loam. Full sun. Better adapted north of I-40.
Pine, Pinyon (<i>Pinus cembroides edulis</i>)	P, NW, SW	L	M	Compact to 30 feet. Excellent for panhandle. Sandy loam, full sun.
*Pine, Ponderosa (<i>Pinus ponderosa</i>)	A	M	H	Very drought and wind tolerant. Well-drained loam to rocky soil. Full sun. Pine Tip borer may be a problem when tree is young.
Pine, Red or Norway (<i>Pinus resinosa</i>)	A	M	H	Well-drained soil. Full sun. Better adapted north of I-40. Pine Tip borer when young.

Table 6.7. Evergreen Trees (cont'd).

	<i>Region</i>	<i>GR</i>	<i>MHt</i>	<i>Comments</i>
Pine, Scots or Scotch (<i>Pinus sylvestris</i>)	A	M	H	Common Christmas tree. Compact forms are available. Pine Tip moth when young. Very susceptible to Pine Wood Nematode. Loam to clay loam.
Pine, Short Leaf (<i>Pinus echinata</i>)	SE, C	L	H	Fairly drought tolerant. Does well in drier, rocky, upland soils. Very picturesque with age.
Pine, Slash (<i>Pinus elliottii</i>)	SE, C	H	H	Loam to clay loam. Sun to part shade. Southeast U.S. forest pine, thus do not make suitable specimen or windbreak plants. Pine Tip moth a problem when young.
Pine, Southwestern White (<i>Pinus strobiformis</i>)	A	M	M	Loam soil. Full sun to part shade. Plants growing well in Stillwater, OK, and Wichita, KS. Grows to 80' tall in New Mexico and southwest U.S.
Pine, Virginia (<i>Pinus virginiana</i>)	A	L	M	Not very ornamental. Grown for Christmas tree industry. Very susceptible to pine tip borer. Clay loam to sandy loam.
Redwood, Dawn (<i>Metasequoia glyptostroboides</i>)	NE, SE, C	H	H	Thrives in deep, well-drained, rich, moist soils. Full sun. May be surface rooted.
Spruce, Dwarf Alberta (<i>Picea glauca</i> 'Conica')	A	L	L	Compact to about 10 feet in 30 years. Spider mites can be a problem in hot weather. Better adapted to northern portions of Oklahoma. Locate in area that is protected from dry winds and late, hot sun. Does best in sandy loam soil with adequate irrigation.
Yew, Anglojap (<i>Taxus x media</i>)	A	L	L	Thayerae and Runyan have performed well in Oklahoma. Yews require excellent drainage. Anything less than excellent and the plants will suffer, decline and die. Do best in deep, rich, moist acid soils. Protect from harsh afternoon sun and dry winter winds. Can be sheared as a hedge.
Yew, Japanese (<i>Taxus cuspidata</i>)	A	L	M	Yews require excellent drainage. Anything less than excellent and the plants will suffer, decline and die. Do best in deep, rich, moist acid soils. Protect from harsh afternoon sun and dry winter winds. Can be sheared as a hedge.

Table 6.8. Deciduous Shrubs (some can grow naturally as small trees or be found grafted as a standard)*

Common Name Botanical Name	Species Characteristics			Comments
	Height ft.	Spread ft.	Region	
Deciduous Shrubs				
Althea or Rose of Sharon (<i>Hibiscus syriacus</i>)	8-12	6-10	A	Wildscape candidate. Red, white, pink and purple flowers.
Barberry, Japanese (<i>Berberis thunbergii</i>)	3-6	4-7	A	Green foliage, small thorns, red fruits.
Barberry, Mentor (<i>B. x mentorensis</i>)	5	5-7	A	Yellow flowers, semi-evergreen.
Barberry, Red leaf (<i>B. thunbergii atropurpurea</i>)	3-6	4-7	A	Reddish or purple foliage, many selections available.
Bayberry (<i>Myrica pensylvanica</i>)	5-12	5-12	NE, SE	Male and female plants needed for good fruit development.
Beautyberry, Purple (<i>Callicarpa dichotoma</i>)	3-4	4-5	A	White fruits available.
Beauty Bush (<i>Kolkwitzia amabilis</i>)	6-10	5-8	A	Prune to expose exfoliating bark.
Blue Mist or Bluebeard Shrub (<i>Caryopteris x candonensis</i>)	3-5	3-5	A	Sometimes freezes back, but regenerates from roots. True blue flowers.
Buddleia, Butterfly Bush (<i>Buddleia davidii</i>)	5-10	4-5	A	Wildscape plant. Attracts butterflies.
Bush Cinquefoil (<i>Potentilla fruticosa</i>)	1-4	2-4	A	May suffer from heat stress. Flowers in a variety of colors.
Buttonbush (<i>Cephalanthus occidentalis</i>)	3-6	3-6	A	Good for growing in or near ponds, but also tolerant of normal landscaping conditions. Glossy foliage, white flowers, button-like fruit.
Carolina Allspice (<i>Calycanthus floridus</i>)	6-9	6-12	A	Fragrant flowers. Prefers deep, moist loam. Adapts to acid and alkaline soils. Shade or sun.
Chokeberry, Black (<i>Aronia melanocarpa</i>)	3-5	3-5	A	Suckers profusely forming large colonies over time. Provides year-round interest.
Chokeberry, Purple-fruited (<i>A. x prunifolia</i>)	8	4-6	A	Tends to sucker. Good for banks and difficult to mow areas.
Chokeberry, Red (<i>A. arbutifolia</i>)	6-10	3-5	A	Tends to sucker. Good for banks and difficult to mow areas.
Cotoneaster, Cranberry (<i>Cotoneaster apiculatus</i>)	3	3-6	A	Occasional disease and insect problems. Showy fruits.
Cotoneaster, Rock (<i>C. horizontalis</i>)	2-3	5-8	A	Occasional disease and insect problems. Showy fruits.
Cotoneaster, Spreading (<i>C. divaricatus</i>)	5-6	6-8	A	Occasional disease and insect problems. Showy fruits.
Crapemyrtle (<i>Lagerstroemia indica</i>)	6-20		A	Many cultivars available. Actual size of plant is based on cultivar. Choose powdery mildew resistant varieties. In colder areas, may freeze back, but will regrow from roots.
Currant, Clove, Missouri, or Golden (<i>Ribes odoratum</i>)	6-8	4-5	A	Yellow, clove-scented flowers, edible fruit.
Dogwood, Red-Osier of Red Twig (<i>Cornus sericea</i>)	7-9	10	A	Hot, humid conditions may lead to decline. Red twigs showy in winter.
Eastern Wahoo (<i>Euonymus atropurpureus</i>)	12-24	8-10	A	Attractive fall color and fruits. Can be trained as a tree.
Euonymus, American or Strawberry-bush (<i>E. americanus</i>)	4-6	3-4	A	Can be infected by scale. Red fall color and showy fruits.

Table 6.8. Deciduous Shrubs (some can grow naturally as small trees or be found grafted as a standard)* (cont'd).

Common Name Botanical Name	Species Characteristics			Comments
	Height ft.	Spread ft.	Region	
Euonymus, Winged (<i>E. alatus</i>)	15-20	15-20	A	Does not contract scale. Dwarf cultivars available, five to 10 feet high and wide.
Fig, Common (<i>Ficus carica</i>)	8-10	5-7	NE, SE	Fruit is edible. May freeze back from harsh winters.
Forsythia (<i>Forsythia x intermedia</i>)	8-10	10-12	A	Very early yellow flowers.
Fothergilla (<i>Fothergilla</i> spp.)	6-10	5-8	NE, SE	Prefers acid soils. Interesting white flowers appear before leaves in early spring. Provide shade for optimal growth; leaf scorch may occur if planted in full sun.
Honeysuckle, Morrow (<i>Lonicera morrowii</i>)	6-8	6-10	A	Red fruits, shrub type habit.
Honeysuckle, Tatarian (<i>L. tatarica</i>)	10-12	10	A	Considered weedy. Many cultivars.
Honeysuckle, Winter (<i>L. fragrantissima</i>)	6-10	6-10	A	Exceptional fragrance. Blooms in Feb.-March. Semi-evergreen.
Hydrangea (<i>Hydrangea</i> spp.)	3-6	3-6	A	Showy flowers, pH sensitive.
Hydrangea, Oakleaf (<i>Hydrangea quercifolia</i>)	4-6	4-6	A	Best in shade, moist soil. Showy flowers, good fall color, many cultivars available. Oklahoma Proven selection.
Jasmine, Winter (<i>Jasminum nudiflorum</i>)	3-4	4-7	A	Flowers December - March. Bright yellow flowers. Young stems bright green.
Kerria, Japanese (<i>Kerria japonica</i>)	3-6	6-9	A	Full shade; bright yellow flowers in late spring/early summer. Green stems are showy in winter. Oklahoma Proven Selection.
Lilac, French or Common (<i>Syringa vulgaris</i> and other related species.)	8-15	6-12	A	Seek out local expertise when choosing lilacs. Besides finding mildew-resistant types, inquire about fragrance, and other ornamental characteristics.
Mockorange, Sweet (<i>Philadelphus coronarius</i> and related spp.)	10-12	10-12	A	Many types available for white, fragrant spring flowers.
Ninebark, dwarf (<i>Physocarpus opulifolius</i>)	5-7	5-6	A	Diablo™ and other purple leaf selections are available.
Paradise Poinciana or Bird of Paradise (<i>Caesalpinia gilliesii</i>)	10	6-8	NE, SE, SW	May freeze out depending upon variety and planting location, but often root hardy. Grow for tropical looking flowers.
Pearl Bush, common (<i>Exochorda racemosa</i> ; <i>E. x macrantha</i>)	10-15	10-15	NE, SE	White flowers.
Pomegranate (<i>Punica granatum</i>)	12-20	12-20	NE, SE	Glossy foliage, orange flowers, edible fruit, may freeze back.
Privet, Common or Hedge plant (<i>Ligustrum vulgare</i>)	12-15	12-15	A	Good for "instant" hedge.
Privet, Golden or Golden Vicary (<i>L. x vicaryi</i>)	10-12	6-8	A	Golden yellow foliage color.
Quince, Flowering (<i>Chaenomeles speciosa</i>)	6-10	6-10	A	White, pink, or red flowers.
Rose (<i>Rosa</i> spp.)	4-6	4-6	A	Seek grower advice for disease resistant cultivars.
Saint John's-wort (<i>Hypericum patulum</i>)	3-4	3-4	A	Yellow summer flowers.

Table 6.8. Deciduous Shrubs (some can grow naturally as small trees or be found grafted as a standard)* (cont'd).

Common Name Botanical Name	Species Characteristics			Comments
	Height ft.	Spread ft.	Region	
Siberian Peashrub (<i>Caragana arborescens</i>)	15-20	12-18	A	Grows well in tough sites, yellow flowers.
Snowberry (<i>Symphoricarpos albus</i>)	3-6	3-6	A	White fruits. <i>S. orbiculatus</i> has pink fruits.
Spirea, Anthony Waterer (<i>Spiraea x bumalda</i> 'Anthony Waterer')	3-4	4-5	A	Pink summer flowers.
Spirea, Magic Carpet (<i>S. japonica</i> 'Magic Carpet')	2-3	2-3	A	Orange-red to reddish purple young new shoots, yellow-gold at maturity, pinkish flowers.
Sumac, Cutleaf (<i>Rhus glabra</i> 'Laciniata')	10-15	10-15	A	Leaflets deeply cut and lobed; produces bright scarlet fruit.
Sumac, Smooth (<i>R. glabra</i>)	10-15	10-15	A	Excellent fall color; crimson fruits on female plants. Suckers form colonies. Tough plant found growing in difficult sites.
Sumac, Staghorn (<i>R. typhina</i>)	15-25	15-25	A	Excellent fall color; crimson fruits on female plants. Suckers form colonies. Tough plant found growing in difficult sites.
Sweetspire, Virginia (<i>Itea virginica</i>)	3-5	3-5	NE, SE	White flower, showy fall color.
Viburnum, Arrowwood (<i>Viburnum dentatum</i>)	6-8	6-15	A	Showy blue fruits. Several cultivars available.
Viburnum, Burkwood (<i>V. x burkwoodii</i>)	8-10	6-8	A	Fragrant flowers.
Viburnum, Doublefile or Japanese (<i>V. plicatum</i> var. <i>tomentosum</i>)	8-10	9-12	NE, SE	White flowers, heavily floriferous.
Viburnum, European or Snowball (<i>V. opulus</i>)	8-12	10-15	A	White flowers, red fruits.
Vitex, or Chaste Tree (<i>Vitex agnus-castus</i>)	8-10	8-10	A	Lavender, pink, or white flowers, attractive foliage. Attracts butterflies. May freeze, but regenerate from roots.
Weigela (<i>Weigela florida</i>)	6-9	9-12	A	Many cultivars.
Willow, Goat or Pussy (<i>Salix caprea</i>)	15-25	12-15	A	Fast growth, showy winter/early spring flowers.
Witch Hazel (<i>Hamamelis vernalis</i>)	6-10	4-5	SW, NE, SE	Grow for winter flowers.

* Many varieties and cultivars of shrubs exist that are not listed. For the sake of brevity, only one or two samples are provided for any given group of plants. For example, there are numerous variations or cultivars of barberry, viburnum and others selected for foliage or flower color, size, etc.

Table 6.9. Evergreen Shrubs.

Common Name – Botanical Name		Species Characteristics		
		Height ft.	Spread ft.	Region
Coniferous Shrubs (Narrowleaf)				
Juniper, Chinese (<i>Juniperus chinensis</i>)		1-25+	3-10	A
Juniper, Creeping (<i>J. horizontalis</i>)		1-2	4-8	A
Juniper, Japgarden (<i>J. procumbens</i>)		3/4-2	10-15	A
Juniper, Rocky Mountain (<i>J. scopulorum</i>)		30-40	3-15	NW, SW
Juniper, Savin (<i>J. sabina</i>)		4-6	5-10	A
Juniper, Shore (<i>J. conferta</i>)		1-2	6-9	A
Pine, Mugo (<i>Pinus mugo</i>)		15-20	25-30	A
Yew, Anglojap (<i>Taxus x media</i>)		2-20		A
Yew, Japanese (<i>T. cuspidata</i>)		5-15	5-15	A
Broadleaf Evergreen Shrubs				
Abelia, Glossy (<i>Abelia x grandiflora</i>)		3-6	3-6	NE, SE, SW
Aucuba (<i>Aucuba japonica</i>)		6-10	5-8	SE (NE)
Azalea, (<i>Rhododendron</i> spp.)		Varies	Varies	NE, SE
Barberry, William Penn (<i>Berberis x gladiwynensis</i> 'William Penn')		4	4	A
Barberry, Wintergreen or Juliane (<i>B. julianae</i>)		6-8	6-8	A
Boxwood, Common or English (<i>Buxus sempervirens</i>)		15-20	15-20	A
Boxwood, Little Leaf (<i>B. microphylla</i>)		3-4	3-4	A
Camellia, Sasanqua (<i>Camellia sasanqua</i>)		6-10		NE, SE
Cherrylaurel or English Laurel (<i>Prunus laurocerasus</i>)		10-18		SW, NE, SE
Cherrylaurel, Carolina (<i>Prunus caroliniana</i>)		20-30	15-25	NE, SE

Size varies significantly depending on cultivar and there are many. Spreading shrub to upright shrub or tree.
Size is also variable, but definitely low-growing, spreading type.

Attractive in planters.

Similar to native eastern red cedar.

Several cultivars available.

May have some shade tolerance.

Low growing forms available from three to six feet tall.

Cultivar Runyan has performed well in Oklahoma.

Size varies with cultivar. The cultivar Thayerae has performed well in Oklahoma.

Comments

May develop severe chlorosis in high pH soils.

Excellent for shady areas. Not drought tolerant. Tolerates moist clay soils. Variegated forms available.

Keep mulched, shelter from sun and wind. Not drought tolerant. High maintenance plant. Flowers and twigs poisonous if eaten. Vast selections available; confer with garden center personnel.

Showy foliage. Semi-evergreen.

Very spiny, makes good barrier or hedge. Lustrous dark green leaves, yellow spring flowers, and bluish black fruits that persist into winter.

Do not cultivate or over fertilize. Winter sunscald if not shaded. Many cultivars available, most grow smaller than species.

Slow growth, showy foliage, good for formal plantings.

Showy fall flowers. Some camellias yield winter flowers. Dark glossy green leaves.

Needs well-drained soil. Fragrant flowers. Toxic foliage.

Evergreen, toxic foliage.

Table 6.9. Evergreen Shrubs (cont'd).

Common Name – Botanical Name	Species Characteristics		Region	Comments
	Height ft.	Spread ft.		
Cotoneaster, Bearberry (<i>Cotoneaster dammeri</i>)	1-1 1/2	6+	A	Semi-evergreen, attractive fruits.
Elaeagnus, Silverberry (<i>Elaeagnus pungens</i>)	10-15	10-15	A	Fruits seldom seen, but may attract birds. Semi-evergreen foliage used in hedges.
Euonymus, Japanese (<i>Euonymus japonica</i> several cultivars)	5-10	5-10	A	Glossy green leaf. Numerous cultivars available. Highly susceptible to scale insect.
Euonymus, Spreading (<i>E. kiautschovicus</i>)	8-10	8-10	A	Fruit not showy, but interestingly attractive. 'Manhattan' cultivar is a superior species.
Euonymus, Winter Creeper (<i>E. fortunei</i>)	1/3-1	3-6+	A	Many cultivars available. Leafspot and scale possible.
Holly, Chinese or Horned (<i>Ilex cornuta</i>)	8-10	10+	NE, SE	Spiny glossy leaf. Shelter from wind. Many cultivars available. Showy fruit on female plants, male is usually required for fruiting.
Holly, The Blue or Meserve Hollies (<i>I. x meserveae</i>)	8-20	4-10	A	Should grow in northwest Oklahoma with shelter. Deep green leaves with blue gloss. Showy fruit on female plants.
Hollies, Fosters Hybrid (<i>I. x attenuata</i>)	20-30		NE, SE	Showy fruit on female plants.
Holly, Inkberry (semi-evergreen) (<i>I. glabra</i>)	6-8	8-10	NE, SE	Many cultivars available. Showy fruit on female plants. Prefers acid, moist soil. Will grow in swampy areas.
Holly, Japanese (<i>I. crenata</i>)	5-10	5-10	NE, SE	Leaves without spines, dark green. Shelter from sun and wind. Best adapted to northeast Oklahoma. Many cultivars available.
Holly, Yaupon (<i>I. vomitoria</i>)	4-20	6-8	A	Tough holly, but likes mulch and light amounts of fertilizer. Leaf without spines, dark green on top with gray-back stems. Dwarf yaupon makes good substitute for boxwood. Can be sheared. More tolerant of wind and sun than other hollies.
Honeysuckle, Winter (<i>Lonicera fragrantissima</i>)	6-10	6-10	A	Very fragrant flowers that bloom in late winter. Semi-evergreen.
Indian Hawthorn (<i>Raphiolepis umbellata</i>)	4-6	4-6	SE, SW	Marginally hardy. Flowers vary from late winter to early summer. Medium drought tolerance. Best for southern portions of Oklahoma.
Laurel, Mountain (<i>Kalmia latifolia</i>)	4-8	4-5	NE, SE	Challenging to grow in Oklahoma, attractive flowers.
Mahonia, Creeping (<i>Mahonia repens</i>)	3/4-1 3/4	3-4	A	Spreading, evergreen groundcover. Yellow spring flowers, grape-like fruit.
Mahonia or Oregon Grape Holly (<i>M. aquifolium</i>)	3-6	3-5	A	Glossy, spiny, dark green leaf, new leaves red purple. Summer grape-like fruit. Best in part shade. Suckers and will form colonies.
Mahonia, Leatherleaf (<i>M. bealei</i>)	6-10	6-8	NE, SE	Large, leathery, stiff, blue green leaf. Flowers are very fragrant. Grape-like fruit. Medium drought tolerance.

Table 6.9. Evergreen Shrubs (cont'd).

Common Name – Botanical Name	Species Characteristics			Region	Comments
	Height ft.	Spread ft.			
Nandina or Heavenly Bamboo (<i>Nandina domestica</i>)	4-8	4-5	A	Lacy leaf. Small red fruit in fall. Tough plant, drought tolerant. Red fall leaf color. Many cultivars available; vary greatly in size. Semi-evergreen.	
Osmanthus or False Holly (<i>Osmanthus heterophyllus</i>)	8-10	6-8	SE	Flowers form in fall, are often hidden, but very fragrant. Shelter, keep mulched, watered and fertilized. Holly look-alike.	
Palmetto, (<i>Sabal minor</i>)	5-8	5	SE, NE	Native to SE Oklahoma. Provides tropical flare to landscape.	
Photinia, Chinese (<i>Photinia serrulata</i>)	20-25	14-16	A	Resistant to leaf spot.	
Photinia, Redtip (<i>P. x fraseri</i>)	10-15	5-8	A	Pretty red new growth, may contract Entomosporium leaf spot. Prune in spring for density. Avoid wet or hot sites. Nitrogen fertilizer beneficial. Drought tolerant.	
Pieris, Japanese (<i>Pieris japonica</i>)	3-4+	6-8	NE, SE	Showy white flowers in spring. Moist, acid, well-drained soil.	
Pittosporum, Japanese (<i>Pittosporum tobira</i>)	10-12	15-24	SE	Should probably be limited to extreme southeast corner of state. Smaller cultivars available. Fragrant creamy white flowers in spring. Relatively tough plant, not too finicky of site.	
Privet, Japanese (<i>Ligustrum japonicum</i>)	6-12	6-8	NE, SE	Sun or heavy shade. Freeze injury possible. Adaptable, withstands heavy pruning. White spring flower, dull black fruits.	
Pyracantha, Scarlet Firethorn (<i>Pyracantha coccinea</i>)	6-18	6-18	A	Outstanding, bright orange-red fruit persisting into winter. Some disease and insect problems. Does well in dry soil. Semi-evergreen.	
Rhododendron (<i>Rhododendron</i> hybrids)	Varies	Varies	NE, SE	Beautiful spring flowers.	
Viburnum, Alleghany (<i>Viburnum x rhytidophylloides</i> 'Alleghany')	10	11	NE, SE, NW, SW	These and many other viburnums are valued for spring flowers, often fragrant, pest free deciduous or evergreen foliage, brilliant fall color, and showy fruits.	
Viburnum, Leatherleaf (<i>Viburnum rhytidophyllum</i>)	10-15	10-15	NE, SE	Showy fruits. Shelter from sun, reflected heat and wind. Not drought tolerant.	
Yucca, Adam's Needle (<i>Yucca filamentosa</i>)	3-4	3-4	A	Cold hardy. Grows about anywhere except very wet sites. Produces yellowish-white pendulous flowers on three to six foot tall stalk in summer.	
Yucca, Red (<i>Hesperaloe parvifolia</i>)	3-4	3-4	A	Dark pink to red flowers arising on a four to five foot stalk.	

* Many varieties and cultivars of shrubs exist that are not listed. However, for the sake of brevity, only one or two samples are provided for any given group of plants. For example, there are numerous variations or cultivars of barberry selected for foliage color, size, etc.

Trees, Shrubs, and Vines Plant Selection Guide

Tolerates or Prefers Dry Locations

Most or all of the trees, shrubs, and vines listed below will require vigilant irrigation for at least the first growing season. However, upon establishment, the plants below are known to tolerate or even prefer dry sites. Tolerance to dry or xeric conditions will widely differ amongst these species, sometimes at the expense of normal flowering, fall color, etc.

Trees

Ash, Green

(*Fraxinus pennsylvanica*)

Bayberry, Northern

(*Myrica pensylvanica*)

Beautybush

(*Kolkwitzia amabilis*)

Buckeye, Red

(*Aesculus pavia*)

Chittimwood

(*Bumelia lanuginosa*)

Corktree, Amur

(*Phellodendron amurense*)

Crabapple

(*Malus* spp.)

Crapemyrtle

(*Lagerstroemia indica*)

Cypress, Bald

(*Taxodium distichum*)

Cypress, Pond

(*Taxodium ascendens*)

Date, Chinese

(*Ziziphus jujuba*)

Desert-Willow

(*Chilopsis linearis*)

Elm

(*Ulmus* spp.)

Empress or Princess Tree

(*Paulownia tomentosa*)

Euonymus, Winterberry

(*Euonymus bungeanus*)

Evodia, Korean

(*Evodia daniellii*)

Filbert, Turkish

(*Corylus colurna*)

Goldenraintree

(*Koelreuteria paniculata*)

Hackberry, Common

(*Celtis occidentalis*)

Hawthorn

(*Crataegus* spp.)

Holly, Deciduous or Possumhaw

(*Ilex decidua*)

Hornbeam, European

(*Carpinus betulus*)

Japanese Pagodatree, Scholar-tree

(*Sophora japonica*)

Juniper, Chinese

(*Juniperus chinensis*)

Juniper, Rocky Mountain

(*Juniperus scopulorum*)

Kentucky Coffeetree

(*Gymnocladus dioica*)

Lilac, Japanese Tree

(*Syringa reticulata*)

Maple, Amur or Ginnala

(*Acer tataricum* ssp. *ginnala*)

Maple, Hedge

(*Acer campestre*)

Maple, Shantung

(*Acer truncatum*)

Maple, Tatarian

(*Acer tataricum*)

Mulberry, Fruitless White

(*Morus alba* 'Fruitless')

Oak, Blackjack

(*Quercus marilandica*)

Oak, Bur

(*Quercus macrocarpa*)

Oak, Chinkapin

(*Quercus muehlenbergii*)

Oak, Red

(*Quercus rubra*)

Oak, Sawtooth

(*Quercus acutissima*)

Oak, Shumard

(*Quercus shumardii*)

Osage Orange 'Whiteshield'

(*Maclura pomifera* 'Whiteshield')

Pear, Ornamental

(*Pyrus calleryana* cultivars)

Pecan

(*Carya illinoensis*)

Persimmon

(*Diospyros* spp.)

Pine, Austrian

(*Pinus nigra*)

Pine, Japanese Black
(*Pinus thunbergiana*)

Pine, Limber
(*Pinus flexilis*)

Pine, Ponderosa
(*Pinus ponderosa*)

Pistache, Chinese
(*Pistacia chinensis*)

Planetree, London
(*Platanus x acerifolia*)

Plum, Mexican
(*Prunus mexicana*)

Redbud
(*Cercis* spp.)

Redcedar, Eastern
(*Juniperus virginiana*)

Russian-Olive
(*Elaeagnus angustifolia*)

Serviceberry
(*Amelanchier* spp.)

Smoketree, Common
(*Cotinus coggygria*)

Soapberry, Western
(*Sapindus drummondii*)

Sumac
(*Rhus* spp.)

Sycamore
(*Platanus occidentalis*)

Yellowwood, American
(*Cladrastis kentukea*)

Zelkova, Japanese
(*Zelkova serrata*)

Shrubs

Abelia, Glossy
(*Abelia x grandiflora*)

Aralia, Fiveleaf
(*Eleutherococcus sieboldianus*)

Aucuba, Japanese
(*Aucuba japonica*)

Barberry, Japanese
(*Berberis thunbergii*)

Barberry, Mentor
(*Berberis x mentorensis*)

Beautyberry, American
(*Callicarpa americana*)

Bluebeard or Blue Mist
(*Caryopteris x clandonensis*)

Blueberry, Highbush
(*Vaccinium corymbosum*)

Bush Cinquefoil
(*Potentilla fruticosa*)

Chokeberry, Black
(*Aronia melanocarpa*)

Chokeberry, Red
(*Aronia arbutifolia*)

Coralberry or Buckbrush
(*Symphoricarpos orbiculatus*)

Coralberry, Chenault
(*Symphoricarpos x chenaultii*)

Cotoneaster, Rock
(*Cotoneaster apiculatus*)

Cotoneaster, Spreading
(*Cotoneaster divaricatus*)

Cotoneaster, Willowleaf
(*Cotoneaster salicifolius*)

Devil's-walkingstick
(*Aralia spinosa*)

Dogwood, Gray
(*Cornus racemosa*)

Dogwood, Roughleaf
(*Cornus asperifolia*
var. *drummondii*)

Firethorn
(*Pyracantha coccinea*)

Holly, Chinese
(*Ilex cornuta*)

Holly, Yaupon
(*Ilex vomitoria*)

Honeysuckle, Morrow
(*Lonicera morrowii*)

Honeysuckle, Southern Bush
(*Diervilla sessilifolia*)

Honeysuckle, Tatarian
(*Lonicera tatarica*)

Honeysuckle, Winter
(*Lonicera fragrantissima*)

Hydrangea, Smooth
(*Hydrangea arborescens*)

Indian Hawthorn
(*Raphiolepis* spp.)

Juniper
(*Juniperus* spp.)

Nandina or Heavenly Bamboo
(*Nandina domestica*)

Ninebark, Diablo
(*Physocarpus opulifolius* Diablo™)

Olive, Autumn
(*Elaeagnus umbellata*)

Paradise Ponciana or Bird of Paradise
(*Caesalpinia gilliesii*)

Pearl Bush
(*Exochorda* spp.)
Photinia
(*Photinia* spp.)
Plum, American
(*Prunus americana*)
Plum, Sand or Chickasaw
(*Prunus angustifolia*)

Privet
(*Ligustrum* spp.)
Quince, Flowering
(*Chaenomeles* spp.)
Rose-of-Sharon or Shrub Althea
(*Hibiscus syriacus*)
Rose, Rugosa
(*Rosa rugosa*)
Saint Johnswort
(*Hypericum* spp.)
Serviceberry, Shadblow
(*Amelanchier canadensis*)
Siberian Peashrub
(*Caragana arborescens*)
Spirea, Anthony Waterer
(*Spiraea x bumalda* 'Anthony Waterer')
Spirea, Vanhoutte
(*Spiraea x vanhouttei*)
Sumac, Fragrant
(*Rhus aromatica*)
Sumac, Smooth
(*Rhus glabra*)
Witchhazel
(*Hamamelis* spp.)
Yellowroot
(*Xanthorhiza simplicissima*)
Yucca
(*Yucca* spp.)

Vines

Akebia, Fiveleaf
(*Akebia quinata*)
Ampelopsis, Porcelain
(*Ampelopsis brevipedunculata*)
Bittersweet, American
(*Celastrus scandens*)
Boston Ivy
(*Parthenocissus tricuspidata*)
Carolina Yellow Jessamine
(*Gelsemium sempervirens*)
Rose, Lady Banksia
(*Rosa banksia*)

Silver Lace Vine
(*Polygonum aubertii*)
Trumpet Creeper or Trumpet Vine
(*Campsis radicans*)
Virginia Creeper
(*Parthenocissus quinquefolia*)
Wisteria
(*Wisteria* spp.)

Tolerates or Prefers Wet Locations

Plants listed below will only tolerate flooding for short periods of time (normally only a few days). Very few, with the exception of bald cypress and a few others, will actually survive long-term submersion of their root systems.

Trees

Alder
(*Alnus* spp.)
Arborvitae
(*Thuja* spp.)
Ash, Green
(*Fraxinus pennsylvanica*)
Birch, River
(*Betula nigra*)
Black Gum
(*Nyssa sylvatica*)
Boxelder
(*Acer negundo*)
Buckeye, Ohio
(*Aesculus glabra*)
Cottonwood, Eastern
(*Populus deltoides*)
Cypress, Bald
(*Taxodium distichum*)
Cypress, Pond
(*Taxodium ascendens*)
Elm, American
(*Ulmus americana*)
Elm, Cedar
(*Ulmus crassifolia*)
Hackberry, Common
(*Celtis occidentalis*)
Hackberry, Sugar
(*Celtis laevigata*)
Hickory, Shagbark
(*Carya ovata*)
Hornbeam, American
(*Carpinus caroliniana*)

Linden, American
(*Tilia americana*)

Maple, Red
(*Acer rubrum*)

Maple, Silver
(*Acer saccharinum*)

Mulberry
(*Morus* spp.)

Oak, Pin
(*Quercus palustris*)

Oak, Red
(*Quercus rubra*)

Oak, Swamp White
(*Quercus bicolor*)

Oak, Water
(*Quercus nigra*)

Pecan
(*Carya illinoensis*)

Pine, Loblolly
(*Pinus taeda*)

Planetree, London
(*Plantanus x acerifolia*)

Soapberry, Western
(*Sapindus drummondii*)

Sweetgum
(*Liquidambar styraciflua*)

Sycamore
(*Platanus occidentalis*)

Willow
(*Salix* spp.)

Shrubs

Beautyberry, Purple
(*Callicarpa dichotoma*)

Buttonbush
(*Cephalanthus occidentalis*)

Chokeberry
(*Aronia* spp.)

Cinquefoil, Bush
(*Potentilla fruticosa*)

Dogwood, Redosier or Red Twig
(*Cornus sericea*)

Dogwood, Roughleaf
(*Cornus asperifolia* var. *drummondii*)

Dogwood, Swamp
(*Cornus amomum*)

Elderberry
(*Sambucus canadensis*)

Holly, Deciduous or Possumhaw
(*Ilex decidua*)

Sweetspire, Virginia
(*Itea virginica*)

Viburnum, European or Snowball
(*Viburnum opulus*)

Waxmyrtle, Southern
(*Myrica cerifera*)

Vine

Rose, Swamp
(*Rosa palustris scandens*)

Tolerates or Prefers Shade

The following plants will perform well under shady conditions.

Trees

Beech
(*Fagus* spp.)

Black Gum
(*Nyssa sylvatica*)

Buckeye, Red
(*Aesculus glabra* spp. *pavia*)

Cherrylaurel, Carolina
(*Prunus caroliniana*)

Dogwood, Flowering
(*Cornus florida*)

Fringetree
(*Chionanthus virginicus*)

Holly
(*Ilex* spp.)

Magnolia, Saucer
(*Magnolia soulangiana*)

Magnolia, Sweetbay
(*Magnolia virginiana*)

Maple, Japanese
(*Acer palmatum*)

Maple, Sugar
(*Acer saccharum*)

Pawpaw
(*Asimina triloba*)

Redbud
(*Cercis* spp.)

Sassafras
(*Sassafras albidum*)

Silverbell
(*Halesia* spp.)

Serviceberry
(*Amelanchier* spp.)

Sourwood
(*Oxydendrum arboreum*)

Yellowwood, American
(*Cladrastis kentukea*)

Shrubs

Abelia, Glossy
(*Abelia x grandiflora*)
Aucuba, Japanese
(*Aucuba japonica*)
Azalea
(*Rhododendron* spp.)
Barberry, Japanese
(*Berberis thunbergii*)
Barberry, Mentor
(*Berberis x mentorensis*)
Boxwood, Common
(*Buxus sempervirens*)
Buttonbush
(*Cephalanthus occidentalis*)
Camellia
(*Camellia* spp.)
Coralberry
(*Symphoricarpos* spp.)
Currant, Golden
(*Ribes alpinum* 'Aureum')
Dogwood, Redosier or Red Twig
(*Cornus sericea*)
Euonymus
(*Euonymus* spp.)
Fothergilla
(*Fothergilla* spp.)
Holly
(*Ilex* spp.)
Honeysuckle, Winter
(*Lonicera fragrantissima*)
Hydrangea
(*Hydrangea* spp.)
Jasmine, Winter
(*Jasminum nudiflorum*)
Jetbead, Black
(*Rhodotypos scandens*)
Kerria, Japanese
(*Kerria japonica*)
Mockorange
(*Philadelphus* spp.)
Mahonia, Creeping
(*Mahonia repens*)
Mahonia, Leatherleaf
(*Mahonia bealei*)
Nandina or Heavenly Bamboo
(*Nandina domestica*)
Pine, Mugo (Dwarf cultivars)
(*Pinus mugo*)
Privet
(*Ligustrum* spp.)

Spirea, Vanhoutte
(*Spiraea x vanhouttei*)
Sweetspire, Virginia
(*Itea virginica*)
Weigela
(*Weigela florida*)
Yew
(*Taxus* spp.)
Viburnum
(*Viburnum* spp.)

Vines

Akebia, Fiveleaf
(*Akebia quinata*)
Ampelopsis, Porcelain
(*Ampelopsis brevipedunculata*)
Boston Ivy
(*Parthenocissus tricuspidata*)
English Ivy
(*Hedera helix*)
Hydrangea, Climbing
(*Hydrangea anomala*)
Honeysuckle, Trumpet
(*Lonicera sempervirens*)
Virginia Creeper
(*Parthenocissus quinquefolia*)
Wintercreeper
(*Euonymus fortunei*)

Tolerates or Prefers Alkaline Soils

Many of the plants listed below will thrive and remain green despite growing in high pH soils. However, when pH values exceed pH 8.0 it may be difficult to grow some of these species.

Trees

Arborvitae
(*Thuja* spp.)
Ash
(*Fraxinus* spp.)
Boxelder
(*Acer negundo*)
Catalpa
(*Catalpa bignonioides*)
Cherrylaurel, Carolina
(*Prunus caroliniana*)
Chittimwood
(*Bumelia lanuginosa*)
Cottonwood
(*Populus* spp.)

Crabapple
(*Malus* spp.)

Crapemyrtle
(*Lagerstroemia indica*)

Date, Chinese
(*Ziziphus jujuba*)

Dawn Redwood
(*Metasequoia glyptostroboides*)

Desert-willow
(*Chilopsis linearis*)

Elm
(*Ulmus* spp.)

Empress or Princess Tree
(*Paulownia tomentosa*)

Ginkgo
(*Ginkgo biloba*)

Goldenraintree
(*Koelreuteria paniculata*)

Hackberry, Common
(*Celtis occidentalis*)

Hawthorn
(*Crataegus* spp.)

Holly, Possumhaw or Deciduous
(*Ilex decidua*)

Honeylocust
(*Gleditsia* spp.)

Japanese Pagodatree, Scholar-tree
(*Sophora japonica*)

Juniper
(*Juniperus* spp.)

Kentucky Coffeetree
(*Gymnocladus dioicus*)

Lilac, Japanese Tree
(*Syringa reticulata*)

Linden
(*Tilia* spp.)

Maple
(*Acer* spp.)

Mulberry
(*Morus* spp.)

Oak, Bur
(*Quercus macrocarpa*)

Oak, Chinkapin
(*Quercus muhlenbergii*)

Oak, English
(*Quercus robur*)

Oak, Post
(*Quercus stellata*)

Oak, Shumard
(*Quercus shumardii*)

Osage Orange
(*Maclura pomifera*)

Pear, Ornamental
(*Pyrus calleryana* cultivars)

Persimmon
(*Diospyros* spp.)

Pistache, Chinese
(*Pistacia chinensis*)

Pine
(*Pinus* spp.)

Planetree, London
(*Platanus x acerifolia*)

Poplar
(*Populus* spp.)

Redbud
(*Cercis* spp.)

Smoketree
(*Cotinus* spp.)

Soapberry, Western
(*Sapindus drummondii*)

Sycamore
(*Platanus occidentalis*)

Walnut
(*Juglans* spp.)

Willow
(*Salix* spp.)

Yellowwood, American
(*Cladrastis kentukea*)

Shrubs

Barberry
(*Berberis* spp.)

Beautyberry, Purple
(*Callicarpa dichotoma*)

Beautybush
(*Kolkwitzia amabilis*)

Bluebeard or Blue Mist
(*Caryopteris x clandonensis*)

Boxwood
(*Buxus* spp.)

Bush Cinquefoil
(*Potentilla fruticosa*)

Butterfly Bush
(*Buddleia davidii*)

Sweet Shrub, Common or
Carolina Allspice
(*Calycanthus floridus*)

Chokeberry
(*Aronia* spp.)

Cotoneaster
(*Cotoneaster* spp.)

Crapemyrtle
(*Lagerstroemia indica*)

Dogwood, Redosier or Red Twig
(*Cornus sericea*)

Euonymus
(*Euonymus* spp.)

Firethorn
(*Pyracantha* spp.)

Forsythia
(*Forsythia* spp.)

Honeysuckle
(*Lonicera* spp.)

Juniper
(*Juniperus* spp.)

Lilac
(*Syringa* spp.)

Mahonia
(*Mahonia* spp.)

Mockorange
(*Philadelphus* spp.)

Nandina or Heavenly Bamboo
(*Nandina domestica*)

Ninebark
(*Physocarpus* spp.)

Pine
(*Pinus* spp.)

Privet
(*Ligustrum* spp.)

Rose-of-Sharon or Shrub Althea
(*Hibiscus syriacus*)

Snowberry
(*Symphoricarpos albus*)

Spirea
(*Spiraea* spp.)

Viburnum
(*Viburnum* spp.)

Yew
(*Taxus* spp.)

Yucca
(*Yucca* spp.)

Vines

Ampelopsis, Porcelain
(*Ampelopsis brevipedunculata*)

Boston Ivy
(*Parthenocissus tricuspidata*)

Dutchman's-pipe
(*Aristolochia macrophylla*)

English Ivy
(*Hedera helix*)

Passion Flowers
(*Passiflora* spp.)

Silver Lace Vine
(*Polygonum aubertii*)

Trumpet Creeper or Trumpet Vine
(*Campsis radicans*)

Virginia Creeper
(*Parthenocissus quinquefolia*)

Tolerates or Prefers Salty Soils

Plants below have varying degrees of tolerance to saline soils. While some may survive salty soils, the homeowner should still expect the possibility of scorched leaves and occasionally overall stunting of the plant.

Trees

Birch, River
(*Betula nigra*)

Black Gum
(*Nyssa sylvatica*)

Buckeye, Bottlebrush
(*Aesculus parviflora*)

Buckeye, Red
(*Aesculus glabra* spp. *pavia*)

Cherry, Sargent
(*Prunus sargentii*)

Corktree, Amur
(*Phellodendron amurense*)

Cypress, Bald
(*Taxodium distichum*)

Cypress, Leyland
(*X Cupressocyparis leylandii*)

Elm, Lacebark
(*Ulmus parvifolia*)

Falsecypress, Hinoki
(*Chamaecyparis obtusa*)

Falsecypress, Japanese
(*Chamaecyparis pisifera*)

Falsecypress, Nootka
(*Chamaecyparis nootkatensis*)

Falsecypress, Whitecedar or Altantic
(*Chamaecyparis thyoides*)

Goldenraintree
(*Koelreuteria paniculata*)

Hornbeam, American
(*Carpinus caroliniana*)

Japanese Pagodatree, Scholar-tree
(*Sophora japonica*)

Juniper, Chinese
(*Juniperus chinensis*)

Lilac, Japanese Tree
(*Syringa reticulata*)

Magnolia, Saucer
(*Magnolia x soulangiana*)

Magnolia, Southern
(*Magnolia grandiflora*)

Maple, Hedge
(*Acer campestre*)

Maple, Amur or Ginnala
(*Acer tataricum* ssp. *ginnala*)

Maple, Japanese
(*Acer palmatum*)

Maple, Paperbark
(*Acer griseum*)

Maple, Sycamore
(*Acer pseudoplatanus*)

Maple, Tatarian
(*Acer tataricum*)

Oak, Red
(*Quercus rubra*)

Oak, Sawtooth
(*Quercus acutissima*)

Oak, Swamp White
(*Quercus bicolor*)

Oak, White
(*Quercus alba*)

Plum, Beach
(*Prunus maritima*)

Redcedar, Eastern
(*Juniperus virginiana*)

Serviceberry, Allegheny
(*Amelanchier laevis*)

Serviceberry, Downy
(*Amelanchier arborea*)

Serviceberry, Shadblow
(*Amelanchier canadensis*)

Sumac, Chinese
(*Rhus chinensis*)

Sumac, Flameleaf
(*Rhus copallina*)

Sumac, Fragrant
(*Rhus aromatica*)

Zelkova, Japanese
(*Zelkova serrata*)

Shrubs

Bayberry, Northern
(*Myrica pensylvanica*)

Blueberry, Highbush
(*Vaccinium corymbosum*)

Bush Cinquefoil
(*Potentilla fruticosa*)

Chokeberry, Black
(*Aronia melanocarpa*)

Chokeberry, Red
(*Aronia arbutifolia*)

Cotoneaster, Rock
(*Cotoneaster apiculatus*)

Cotoneaster, Spreading
(*Cotoneaster divaricatus*)

Cotoneaster, Willowleaf
(*Cotoneaster salicifolius*)

Holly, Inkberry
(*Ilex glabra*)

Holly, Japanese
(*Ilex crenata*)

Honeysuckle, Southern Bush
(*Diervilla sessilifolia*)

Hydrangea, Bigleaf
(*Hydrangea macrophylla*)

Hydrangea, Oakleaf
(*Hydrangea quercifolia*)

Hydrangea, Panicle
(*Hydrangea paniculata*)

Hydrangea, Smooth
(*Hydrangea arborescens*)

Juniper, Shore
(*Juniperus conferta*)

Lilac, Littleleaf
(*Syringa microphylla*)

Lilac, Manchurian
(*Syringa patula* 'Miss Kim')

Lilac, Meyer
(*Syringa meyeri* 'Palibin')

Privet, Amur
(*Ligustrum amurense*)

Rose, Rugosa
(*Rosa rugosa*)

Viburnum, Arrowwood
(*Viburnum dentatum*)

Viburnum, Blackhaw
(*Viburnum prunifolium*)

Viburnum, Siebold
(*Viburnum sieboldii*)

Yew, Anglojap
(*Taxus x media* cultivars)

Yew, Japanese
(*Taxus cuspidata*)

Winter Interest

Many plants have ornamental merit during the cold months. There are a number of other attributes to seek out in addition to flowers. Many plants have characteristics that set them above other plants; for example - the exquisite bark colors and textures of Heritage river birch, the colorful fruit of the deciduous hollies that persist into the winter, and the unusual branching habit of Harry Lauder's walkingstick.

If looked at for typical reasons, please realize, that some of the plants mentioned ARE NOT the best species to include in the landscape. Compromise in plant selection may be necessary for maximum winter beauty to be realized. Again, please know that plants were mentioned and/or listed below because of their ability to brighten a dull, winter day. They may not be ideal plants for certain settings if the need for winter beauty is not considered.

Showy Bark and Branches or Unusual Form

Trees

Beech
(*Fagus* spp.)
Birch, Heritage River
(*Betula nigra* 'Heritage')
Crapemyrtle
(*Lagerstroemia* spp.)
Cypress, Bald
(*Taxodium* spp.)
Dawn Redwood
(*Metasequoia glyptostroboides*)
Elm, Cedar
(*Ulmus crassifolia*)
Elm, Lacebark
(*Ulmus parvifolia*)
Elm, Winged
(*Ulmus alata*)
Harry Lauder's Walkingstick
(*Corylus avellana* 'Contorta')
Maple, Japanese
(*Acer palmatum*)
Maple, Paperbark
(*Acer griseum*)
Persimmon
(*Diospyros virginiana*)
Pine
(*Pinus* spp.)

Planetree, London
(*Platanus x acerifolia*)
Sycamore
(*Platanus occidentalis*)

Shrubs

Beautybush
(*Kolkwitzia amabilis*)
Burning Bush
(*Euonymus alatus*)
Dogwood, Redosier or Red Twig
(*Cornus sericea*)
Dogwood, Yellowtwig
(*Cornus sericea* 'Flaviramea')
Honeysuckle
(*Lonicera* spp.)
Kerria, Japanese
(*Kerria japonica*)

Interesting or Showy Fruit

Trees

Crabapple
(*Malus* spp.)
Euonymus
(*Euonymus* spp.)
Goldenraintree
(*Koelreuteria paniculata*)
Hawthorn
(*Crataegus* spp.)
Holly, American
(*Ilex opaca*)
Holly, Deciduous or Possumhaw
(*Ilex decidua*)
Japanese Pagodatree, Scholar-tree
(*Sophora japonica*)
Juniper
(*Juniperus* spp.)
Kentucky Coffeetree
(*Gymnocladus dioicus*)
Linden or Basswood
(*Tilia* spp.)
Pistache, Chinese
(*Pistacia chinensis*)
Soapberry, Western
(*Sapindus drummondii*)

Shrubs

Barberry, Japanese
(*Berberis thunbergii*)

Beautyberry, Japanese
(*Callicarpa japonica*)

Buckthorn, Carolina
(*Rhamnus caroliniana*)

Buffaloberry, Silver
(*Shepherdia argentea*)

Buttonbush
(*Cephalanthus occidentalis*)

Chokeberry, Black
(*Aronia melanocarpa*)

Chokeberry, Red
(*Aronia arbutifolia*)

Coralberry or Buckbrush
(*Symphoricarpos orbiculatus*)

Cotoneaster
(*Cotoneaster* spp.)

Dogwood
(*Cornus* spp.)

Elder
(*Sambucus* spp.)

Euonymus
(*Euonymus* spp.)

Firethorn
(*Pyracantha* spp.)

Harry Lauder's Walkingstick
(*Corylus avellana* 'Contorta')

Hardy Orange
(*Poncirus trifoliata*)

Holly
(*Ilex* spp. and hybrids)

Honeysuckle, Morrow
(*Lonicera morrowii*)

Honeysuckle, Tatarian
(*Lonicera tatarica*)

Jetbead, Black
(*Rhodotypos scandens*)

Juniper
(*Juniperus* spp.)

Mahonia
(*Mahonia* spp.)

Nandina or Heavenly Bamboo
(*Nandina domestica*)

Privet
(*Ligustrum* spp.)

Sumac
(*Rhus* spp.)

Viburnum
(*Viburnum* spp.)

Vines

Ampelopsis
(*Ampelopsis* spp.)

Bittersweet
(*Celastrus* spp.)

Clematis
(*Clematis* spp.)

Grape
(*Vitis* spp.)

Plants with Flowers During Winter and Early Spring

Camellia
(*Camellia* spp.)

Forsythia
(*Forsythia* spp.)

Jasmine, Winter
(*Jasminum nudiflorum*)

Honeysuckle, Winter
(*Lonicera fragrantissima*)

Quince, Flowering
(*Chaenomeles* spp.)

Spirea
(*Spiraea* spp.)

Witchhazel
(*Hamamelis* spp.)

Winterhazel
(*Corylopsis* spp.)

Trees, Shrubs, and Vines with Showy Flowers

We expect herbaceous annual and perennial ornamental plants to bloom in the landscape, but when we have trees, shrubs, or vines that bloom, that is an added bonus. Flowers provide changing interest throughout the year. The following plants provide colorful, showy flowers at different times during the growing season.

Trees

Buckeye
(*Aesculus* spp.)

Silverbell, Carolina
(*Halesia tetraptera*)

Catalpa
(*Catalpa* spp.)

Chestnut, Chinese
(*Castanea mollissima*)

Crabapple
(*Malus* spp.)

Crapemyrtle
(*Lagerstroemia* spp.)

Desert-Willow
(*Chilopsis linearis*)

Dogwood, Flowering
(*Cornus florida*)

Empress or Princess tree
(*Paulownia tomentosa*)

Fringetree
(*Chionanthus virginicus*)

Goldenraintree
(*Koelreuteria paniculata*)

Hawthorn
(*Crataegus* spp.)

Japanese Pagodatree, Scholar-tree
(*Sophora japonica*)

Lilac, Japanese Tree
(*Syringa reticulata*)

Magnolia
(*Magnolia* spp.)

Ornamental Pear (cultivars)
(*Pyrus calleryana*)

Plum, Purpleleaf
(*Prunus cerasifera* 'Atropurpurea')

Redbud
(*Cercis* spp.)

Serviceberry
(*Amelanchier* spp.)

Smoketree
(*Cotinus* spp.)

Tuliptree
(*Liriodendron tulipifera*)

Vitex or Chastetree
(*Vitex* spp.)

Yellowwood, American
(*Cladrastis kentukea*)

Shrubs

Abelia, Glossy
(*Abelia x grandiflora*)

Azalea
(*Rhododendron* spp.)

Barberry
(*Berberis* spp.)

Beautyberry, Japanese
(*Callicarpa japonica*)

Beautybush
(*Kolkwitzia amabilis*)

Bluebeard or Blue Mist
(*Caryopteris x clandonensis*)

Bush Cinqfoil
(*Potentilla fruticosa*)

Buttonbush
(*Cephalanthus occidentalis*)

Butterfly Bush
(*Buddleia* spp.)

Camellia
(*Camellia* spp.)

Cherrylaurel, Carolina
(*Prunus caroliniana*)

Cherrylaurel, Common
(*Prunus laurocerasus*)

Cleyera
(*Cleyera japonica*)

Cotoneaster
(*Cotoneaster* spp.)

Crapemyrtle
(*Lagerstroemia* spp.)

False Spirea
(*Caryopteris* spp.)

Firethorn
(*Pyracantha coccinea*)

Flowering Quince
(*Chaenomeles* spp.)

Forsythia
(*Forsythia* spp.)

Honeysuckle
(*Lonicera* spp.)

Hydrangea
(*Hydrangea* spp.)

Indian Hawthorn
(*Raphiolepis* spp.)

Jasmine, Winter
(*Jasminum nudiflorum*)

Lilac
(*Syringa* spp.)

Mahonia
(*Mahonia* spp.)

Mockorange
(*Philadelphus* spp.)

Mountain Laurel
(*Kalmia latifolia*)

Nandina or Heavenly Bamboo
(*Nandina domestica*)

Otto Luyken Laurel
(*Prunus laurocerasus* 'Otto Luyken')

Pearl Bush
(*Exochorda* spp.)

Photinia
(*Photinia* spp.)

Plum, Sand or Chickasaw
(*Prunus angustifolia*)

Rose
(*Rosa* spp.)

Rose-of-Sharon or Shrub Althea

(*Hibiscus syriacus*)

Siberian Peashrub

(*Caragana arborescens*)

Spirea

(*Spiraea* spp.)

Saint Johnswort

(*Hypericum* spp.)

Sweet Shrub, Common or

Carolina Allspice

(*Calycanthus floridus*)

Sweetspire, Virginia

(*Itea virginica*)

Viburnums

(*Viburnum* spp.)

Vitex, Chastetree

(*Vitex agnus-castus*)

Weigela

(*Weigela florida*)

Witchhazel

(*Hamamelis* spp.)

Vines

Carolina Yellow Jessamine

(*Gelsemium sempervirens*)

Clematis hybrids and species

(*Clematis* spp.)

Climbing Roses

(*Rosa* spp.)

Crossvine

(*Bignonia capreolata*)

Honeysuckle, Trumpet

(*Lonicera sempervirens*)

Hydrangea, Climbing

(*Hydrangea anomala*)

Passionflower Vine

(*Passiflora* spp.)

Silver Lace Vine

(*Polygonum aubertii*)

Trumpet Creeper or Trumpet Vine

(*Campsis radicans*)

Wisteria

(*Wisteria* spp.)

Trees, Shrubs, and Vines for Fall Color

Many factors influence the quality and intensity of fall color for any given year. Some of the plants listed below have specific species and/or cultivars that are known for reliable and markedly vivid fall color. When fall color is the priority trait desired, it

is advisable to purchase the plant in the fall when such colors can be viewed and critiqued by the consumer.

Trees

Ash

(*Fraxinus* spp.)

Beech

(*Fagus* spp.)

Birch

(*Betula* spp.)

Black Gum

(*Nyssa sylvatica*)

Buckeye, Ohio

(*Aesculus glabra*)

Crapemyrtle

(*Lagerstroemia* spp.)

Cypress, Bald

(*Taxodium distichum*)

Dawn Redwood

(*Metasequoia glyptostroboides*)

Dogwood, Flowering

(*Cornus florida*)

Elm, American

(*Ulmus americana*)

Fringetree

(*Chionanthus virginicus*)

Ginkgo

(*Ginkgo biloba*)

Goldenraintree

(*Koelreuteria paniculata*)

Hawthorn

(*Crataegus* spp.)

Hornbeam, American

(*Carpinus caroliniana*)

Kentucky Coffeetree

(*Gymnocladus dioica*)

Linden

(*Tilia* spp.)

Maple

(*Acer* spp.)

Oak

(*Quercus* spp.)

Osage Orange 'Whiteshield'

(*Maclura pomifera* 'Whiteshield')

Pear, Ornamental

(*Pyrus calleryana* selections)

Pistache, Chinese

(*Pistacia chinensis*)

Redbud

(*Cercis* spp.)

Silverbell, Carolina
(*Halesia tetraptera*)
Soapberry, Western
(*Sapindus drummondii*)
Sourwood
(*Oxydendrum arboreum*)
Sweetgum
(*Liquidambar styraciflua*)
Tuliptree
(*Liriodendron tulipifera*)
Walnut, Black
(*Juglans nigra*)
Yellowwood, American
(*Cladrastis kentukea*)
Zelkova, Japanese
(*Zelkova serrata*)

Shrubs

Barberry, Japanese
(*Berberis thunbergii*)
Beautyberry
(*Callicarpa* spp.)
Blueberry
(*Vaccinium* spp.)
Chokeberry
(*Aronia* spp.)
Cotoneaster
(*Cotoneaster* spp.)
Crapemyrtle
(*Lagerstroemia* spp.)
Dogwood
(*Cornus* spp.)
Euonymus, Winged
(*Euonymus alata*)
Forsythia
(*Forsythia* spp.)
Fothergilla
(*Fothergilla* spp.)
Hydrangea, Oakleaf
(*Hydrangea quercifolia*)
Mahonia, Creeping
and Oregon Grapeholly
(*Mahonia repens* and *M. aquifolium*)
Nandina or Heavenly Bamboo
(*Nandina domestica*)
Ninebark
(*Physocarpus* spp.)
Parrotia, Persian
(*Parrotia persica*)
Serviceberry
(*Amelanchier* spp.)

Smoketree, Common
(*Cotinus coggygia*)
Spirea
(*Spiraea* spp.)
Sumac
(*Rhus* spp.)
Sweetshrub, Common or
Carolina Allspice
(*Calycanthus floridus*)
Sweetspire, Virginia
(*Itea virginica*)
Viburnum
(*Viburnum* spp.)
Witchhazel
(*Hamamelis* spp.)

Vines

Boston Ivy
(*Parthenocissus tricuspidata*)
Virginia Creeper
(*Parthenocissus quinquefolia*)
Wintercreeper
(*Euonymus fortunei*)

When fall color is the priority trait desired, it is advisable to purchase the plant in the fall when such colors can be viewed and critiqued by the consumer.

Trees for Use Under Power Lines

Just a few of many possible plants for use under power lines are listed below. All will be slow to reach a height as to interfere with overhead lines. Again, some plants below have the genetic potential over many years to actually reach power lines. Do not forget to look for the availability of dwarf cultivars in any species for growing under such structures.

Crabapple
(*Malus* spp.)
Crapemyrtle
(*Lagerstroemia* spp.)
Dogwood, Flowering
(*Cornus florida*)
Euonymus, Winterberry
(*Euonymus bungeanus*)
Hawthorn
(*Crataegus* spp.)
Holly, Possumhaw or Deciduous
(*Ilex decidua*)

Holly, Yaupon
(*Ilex vomitoria*)

Magnolia, Star
(*Magnolia stellata*)

Maple, Amur
(*Acer tataricum* spp. *ginnala*)

Maple, Shantung
(*Acer truncatum*)

Pine, Mugo
(*Pinus mugo*)

Redbud
(*Cercis* spp.)

Rose-of-Sharon or Shrub Althea
(*Hibiscus syriacus*)

Serviceberry
(*Amelanchier* spp.)

Smoketree
(*Cotinus* spp.)

Trees and Shrubs for the Garden, Patio, or Large Architectural Containers

Just a few of the many plants that are candidates for containers are listed below. Realistically, some plants do not perform well or outgrow containers after many years. If permanent plantings are the expectation, check with garden center personnel for the best plant(s) to use for long-term success.

Trees

Crabapple
(*Malus* spp.)

Crapemyrtle
(*Lagerstroemia* spp.)

Desert-Willow
(*Chilopsis linearis*)

Elm, Seijou Lacebark
(*Ulmus parvifolia* 'Seijou')

Euonymus, Winterberry
(*Euonymus bungeanus*)

Falsecypress, Hinoki
(*Chamaecyparis obtusa* cultivars)

Goldenraintree
(*Koelreuteria paniculata*)

Harry Lauder's Walkingstick
(*Corylus avellana* 'Contorta')

Holly, Deciduous and Evergreen
(*Ilex* spp.)

Maple, Amur
(*Acer tataricum* ssp. *ginnala*)

Maple, Japanese
(*Acer palmatum*)

Maple, Paperbark
(*Acer griseum*)

Maple, Shantung
(*Acer truncatum*)

Maple, Tatarian
(*Acer tataricum*)

Maple, Trident
(*Acer buergerianum*)

Pine, Mugo (Dwarf cultivars)
(*Pinus mugo*)

Plum, Purpleleaf
(*Prunus cerasifera* 'Atropurpurea')

Redbud, Eastern
(*Cercis canadensis*)

Redbud, Oklahoma
(*Cercis canadensis* ssp. *texensis* 'Oklahoma')

Smoketree, Common
(*Cotinus coggygria*)

Shrubs

Abelia, Glossy
(*Abelia x grandiflora*)

Barberry
(*Berberis* spp.)

Holly, Evergreen and Deciduous
(*Ilex* spp.)

Juniper
(*Juniperus* spp.)

Mahonia, Creeping
(*Mahonia repens*)

Nandina or Heavenly Bamboo
(Dwarf selections)
(*Nandina domestica*)

Yew
(*Taxus* spp.)

Small Shrubs for Small Spaces

Many species have cultivars that have been selected for their short height or narrow width at maturity.

Arborvitae, Dwarf
(*Thuja* spp.)

Crapemyrtles, Miniature
(*Lagerstroemia* spp.)

Dwarf Alberta Spruce
(*Picea glauca* 'Conica')

Euonymus, Dwarf Box Leaf
(*Euonymus japonicus* 'Microphyllus')

Indian Hawthorne, Ballerina
(*Raphiolepis* spp.)

Junipers, Creeping
(*Juniperus* spp.)

Mahonia, Creeping
(*Mahonia repens*)

Myrtle, Dwarf
(*Myrica* spp.)

Nandina or Heavenly Bamboo
(Dwarf selections)
(*Nandina domestica*)

Pine, Mugo (Dwarf cultivars)
(*Pinus mugo*)

Pomegranate, Dwarf
(*Punica granatum* 'Elf')

Roses, Miniature
(*Rosa* spp.)

Trees, Shrubs, and Vines that Attract Wildlife

Many gardeners not only enjoy plants in the landscape, but also the wildlife that may be attracted to it. The following plants may attract wildlife by the fruits they produce or by providing physical protection.

Trees

Birch, River
(*Betula nigra*)

Black Gum
(*Nyssa sylvatica*)

Buckeye
(*Aesculus* spp.)

Buckthorn, Carolina
(*Rhamnus caroliniana*)

Cherry and Plum
(*Prunus* spp.)

Crabapple
(*Malus* spp.)

Desert-Willow
(*Chilopsis linearis*)

Dogwood
(*Cornus* spp.)

Elm, Lacebark
(*Ulmus parvifolia*)

Hackberry
(*Celtis* spp.)

Hawthorn
(*Crataegus* spp.)

Hickory
(*Carya* spp.)

Holly
(*Ilex* spp.)

Magnolia, Southern
(*Magnolia grandiflora*)

Maple
(*Acer* spp.)

Mulberry
(*Morus* spp.)

Oak
(*Quercus* spp.)

Pawpaw
(*Asimina triloba*)

Pear
(*Pyrus* spp.)

Pecan
(*Carya illinoensis*)

Persimmon, American
(*Diospyros virginiana*)

Pine
(*Pinus* spp.)

Plum, American Red
(*Prunus americana*)

Redcedar, Eastern
(*Juniperus virginiana*)

Russian-Olive
(*Elaeagnus angustifolia*)

Sassafras
(*Sassafras albidum*)

Serviceberry
(*Amelanchier* spp.)

Soapberry, Western
(*Sapindus drummondii*)

Tuliptree
(*Liriodendron tulipifera*)

Waxmyrtle, Southern
(*Myrica cerifera*)

Shrubs

Abelia
(*Abelia* spp.)

Azalea
(*Rhododendron* spp.)

Barberry
(*Berberis* spp.)

Bayberry, Northern
(*Myrica pensylvanica*)

Beautyberry
(*Callicarpa* spp.)

Blackberry
(*Rubus* spp.)

Blueberry
(*Vaccinium* spp.)
Buckthorn, Carolina
(*Rhamnus caroliniana*)
Burning Bush
(*Euonymus atropurpureus*)
Butterfly Bush
(*Buddleia* spp.)
Cherrylaurel, Carolina
(*Prunus caroliniana*)
Currant, Clove
(*Ribes odoratum*)
Currant, Indian Snowberry (Buckbrush)
(*Symphoricarpos orbiculatus*)
Dogwood, Roughleaf
(*Cornus asperifolia* var. *drummondii*)
Elder, American
(*Sambucus canadensis*)
Firethorn
(*Pyracantha* spp.)
Mahonia
(*Mahonia* spp.)
Holly
(*Ilex* spp.)
Juniper
(*Juniperus* spp.)
Magnolia, Sweetbay
(*Magnolia virginiana*)
New Jersey Tea
(*Ceanothus americanus*)
Olive, Autumn
(*Elaeagnus* spp.)
Plum, Sand or Chickasaw
(*Prunus augustifolia*)
Privet
(*Ligustrum* spp.)
Quince, Flowering
(*Chaenomeles* spp.)

Rose
(*Rosa* spp.)
Spicebush
(*Lindera benzoin*)
Strawberry Bush
(*Euonymus americanus*)
Sumac
(*Rhus* spp.)
Viburnum
(*Viburnum* spp.)
Weigela
(*Weigela* spp.)
Yucca
(*Yucca* spp.)

Vines

Bittersweet, American
(*Celastrus scandens*)
Boston Ivy
(*Parthenocissus tricuspidata*)
Cross Vine (Trumpet Flower)
(*Bignonia capreolata*)
English Ivy
(*Hedera helix*)
Grapes
(*Vitis* spp.)
Honeysuckle
(*Lonicera* spp.)
Passion Flower
(*Passiflora* spp.)
Pepper Vine
(*Ampelopsis arborea*)
Pipevine
(*Aristolochia* spp.)
Trumpet Creeper or Trumpet Vine
(*Campsis radicans*)
Virginia Creeper
(*Parthenocissus quinquefolia*)

Ornamentals Part 4

INDOOR PLANTS

LEARNING OBJECTIVES

After completing this section, Master Gardener trainees will be able to:

- Differentiate between high and low light levels and discuss methods of providing artificial light for indoor plants.
- Understand the concept of humidity and explain several methods of providing additional humidity to plants.
- Describe several characteristics of a suitable plant container.
- Select and/or mix a suitable growing medium.
- Determine when and how to fertilize indoor plants.
- Explain how and when to water plants and discuss water quality.
- Describe several common methods of propagating indoor plants.
- Recognize some common signs of insect and disease problems of indoor plants and suggest methods of control.

Indoor Plants

This section includes information on basic aspects of indoor plant care, rather than attempting to acquaint you with specific cultural requirements of more than 250 commonly grown plants in the foliage industry. In most cases, homes and offices are environments poorly suited to the needs of plants. Thus the task of the indoor plant gardener is to select plants that can best withstand the conditions of a specific indoor location.

Selecting an Interior Plant

Select only those plants free of insects and diseases. Check the undersides of the foliage and the axils of leaves for signs of insects or disease. Select plants that look sturdy, clean, well-potted and shapely.

Choose plants with healthy foliage.

Avoid plants that have yellow or chlorotic leaves, brown leaf margins, wilted foliage, spots or blotches or spindly growth. In addition, avoid those with torn leaves and those that have been treated with “leaf shine,” which adds an unnatural polish to the

leaves. Plants with young growth, new flowers and leaf buds are usually of superior quality.

Remember — it is easier to purchase a plant that tolerates the environmental conditions of the residence than to alter the environment to suit the plant.

Transporting houseplants. When transporting plants, remember the two seasons of the year that can most readily cause damage to plants—the hot summer and the cold winter months. In the summer, avoid placing plants in a hot car and leaving them. Temperatures will rise and destroy the plant in a short period of time. If traveling for any distance, the plant can be burned by sunlight shining on it, even though the air conditioner is on and it's comfortable in the car. Shade the plant from direct sun while it is in the car.

During winter months, wrap plants thoroughly before carrying them to your car. A short run from the store to the car in very low temperatures can kill or severely damage plants. Wrap plants thoroughly with newspaper or paper bags, place in the front of the car, and turn on the heater. The trunks of most cars are too cold to carry plants safely during winter months.

On an extended trip, make special arrangements so plants will not be frozen or damaged by cold weather. Many plants will be damaged considerably if the temperature drops much below 50 F.

Acclimatization. Research conducted in Florida in the late 1970s revealed an interesting phenomenon. Tropical plants grown in full sun have leaves (so-called sun leaves) that are structurally different from the leaves of plants grown in shade (shade leaves). Sun leaves have fewer chloroplasts, thus less chlorophyll. Their chloroplasts are located deep inside the leaves and the leaves are thick, small and numerous. Shade leaves have greater numbers of chloroplasts, thus, more chlorophyll, are thin, large and few. When plants are grown in strong light, they develop sun leaves that are photosynthetically very inefficient. If these same plants are placed in low light, they will drop many of their sun leaves and grow new shade leaves that are photosynthetically more efficient. To reduce the shock that occurs when a plant with sun leaves is placed in shade, gradually reduce the light levels to which it is exposed. This process is called acclimatization. The gardener should acclimatize plants when placing them outdoors in summer by gradually increasing light intensities, and should reverse the process before plants are brought indoors in the fall. For newly purchased plants grown in high-light conditions, acclimatize them by initially locating them in a high-light (southern exposure) area of your home and gradually moving them to their permanent, darker location over a period of four to eight weeks.

Environmental Factors

Light, water, temperature, humidity, ventilation, fertilization and potting substrate are chief factors affecting plant growth. Any one of these factors in incorrect quantity will prevent proper plant growth indoors.

Light – Light is probably the most limiting factor for indoor plant growth. The growth of plants and the length of time they remain active depend on the amount of light received. Light is necessary for all plants because they use this energy source to photosynthesize. When examining light levels for indoor plants, consider three aspects of light: intensity, duration and quality.

Light intensity influences the manufacture of plant food, stem length, leaf color and flowering.

A geranium grown in low light tends to be spindly and the leaves light green in color. A similar plant grown in very bright light would tend to be more compact, better branched and have larger, dark green leaves. Indoor plants can be classified according to their light needs by high, medium and low light requirements. The intensity of light a plant receives indoors depends upon the nearness of the light source to the plant (light intensity decreases rapidly when moving away from the source of light). The direction the windows in the home face will affect the intensity of natural sunlight that plants receive. Southern exposures have the most intense light, eastern and western exposures receive about 60 percent of the intensity of southern exposures, and northern exposures receive 20 percent of a southern exposure. A southern exposure is the warmest, eastern and western are less warm, and a northern exposure is the coolest. Other factors that can influence the intensity of light penetrating a window are the presence of curtains, trees outside the window, weather, seasons of the year, shade from other buildings and the cleanliness of the window. Reflective (light-colored) surfaces inside the home/office will increase the intensity of light available to plants. Dark surfaces will decrease light intensity.

Day length or duration of light received by plants is also of some importance, but generally only to those plants that are photoperiodic (responsive to day length). Poinsettia, kalanchoe and Holiday cacti initiate flower buds only when day length is short (11 hours of daylight or less during a 24 hour period). Most flowering indoor plants are indifferent to day length.

Low light intensity can be compensated by increasing the time (duration) the plant is exposed to light, as long as the plant is not sensitive to day length for its flowering response. Increased hours of lighting allow the plant to make sufficient food to survive and/or grow. However, plants require some period of darkness to develop properly and should be illuminated for no more than 16 hours in a 24-hour period. Excessive light is as harmful as too little light. When a plant gets too much direct light, the leaves become pale, sometimes burn, turn brown and die; therefore, during the summer months, protect plants from too much direct sunlight.

Either incandescent or fluorescent lights may supply additional lighting. Incandescent lights pro-

duce a great deal of heat and are not very efficient producers of light. If artificial lights are to be used as the only source of light for growing plants, the quality of light (wavelength) must be considered. For photosynthesis, plants require mostly blues and reds, but for flowering, far red light is needed. Incandescent lights produce mostly red, and some far red light, but are very low in blues. Fluorescent lights vary according to the phosphors used by the manufacturer. "Cool-white" fluorescent lights produce mostly blue light, and are low in red light. Foliage plants grow well under cool-white fluorescent lights, which are also cool enough to position quite close to plants. Blooming plants require more red and far red wavelengths that can be supplied by incandescent lights or special horticultural-type fluorescent lights.

Water – Overwatering and underwatering account for a large percentage of houseplant losses. The most common question gardeners ask is, "How often should I water my plants?" There is not a good answer to this question. Some plants like drier conditions than others. Differences in potting medium and environment influence watering needs. Watering as soon as the substrate's surface dries can result in overwatering.

Plant roots are usually in the bottom 2/3 of the pot; so do not water until the bottom 2/3 starts to dry out slightly. You can't tell this by looking. You have to feel the potting substrate. For a 6-inch pot, stick your index finger about 2 inches into the substrate (approximately to the second joint of a finger). If the substrate feels damp, don't water. Keep repeating the test until the substrate is barely moist at the 2-inch depth. For smaller pots, 1 inch into the substrate is the proper depth to measure.

Water the pot until water runs out of the bottom. This serves two purposes. First, it flushes out excess salts (fertilizer residue). Second, it guarantees that the bottom 2/3 of the pot, which contains most of the roots, receives sufficient water. Don't let the pot sit in the water that runs out. After a thorough watering, wait until the substrate nearly dries at the previously discussed depth before watering again.

When testing for watering, pay attention to the substrate. If your finger can't penetrate 2 inches deep, either a more porous potting mix is needed or the plant is becoming root-bound and should be repotted.

Temperature – Most houseplants tolerate normal temperature fluctuations. In general, indoor foliage plants grow best between 70 F and 80 F during the day and from 60 F to 68 F at night. Some flowering indoor plants prefer the same daytime range, but grow best at nighttime temperatures from 55 F to 60 F. The lower night temperature induces physiological recovery from moisture loss, intensifies flower color and prolongs flower life. Excessively low or high temperatures may cause plant failures, stop growth or cause spindly appearance and foliage damage or drop. A cooler temperature at night is actually more desirable for plant growth than higher temperatures. A good rule is to keep the night temperature 10 F to 15 F lower than the day temperature.

Humidity – Atmospheric humidity is expressed as a percentage of the moisture saturation of air. To provide increased humidity, attach a humidifier to the heating or ventilating system in the home, or place gravel trays (in which an even water level is maintained) under the plant containers. This will increase the relative humidity in the vicinity of the containers. As the moisture around the pebbles evaporates, the relative humidity is raised (Figure 6.59).

Another way to raise humidity is to group plants close together. A fine mist can be sprayed on the foliage, but it is doubtful total humidity modification will be achieved. Spray plants early in the day so they will be dry by night to reduce the chance of



Figure 6.59. A layer of gravel or pebbles increases the humidity level.

disease. Cool dampness at night provides an ideal environment for disease infection.

Ventilation – Indoor plants, especially flowering varieties, are very sensitive to drafts or heat from registers. Forced air heat dries plants rapidly and may cause damage or plant loss by overtaxing their limited root systems. Plants are sensitive to natural or blended gas used for home heating. Some plants refuse to flower, while others drop flower buds and foliage when exposed to heating fuel gas. Blended gases are more toxic to plants than natural gases. Tomato plants are extremely sensitive to gas. They will turn yellow before the escaping gas is detected by household members, and are sometimes used in greenhouses as indicator plants for excessive ethylene gas (resulting from incomplete combustion in gas furnaces).

Fertilization – Indoor plants, like most other plants, need a complete fertilizer – one containing three major elements: nitrogen (N), phosphorus (P) and potassium (K). Fertilizers are available in many different formulations and a multitude of brand names. The analysis of each brand should be on the label, indicating specifically how much water-soluble elemental nitrogen, phosphate or potash is available in every pound of the product. The majority of these fertilizers are about 20-20-20. The first figure indicates available nitrogen; the second, phosphorus pentoxide (P_2O_5); and the third, water-soluble potash (K_2O). Commercial fertilizers used for indoor plants are sold in granular, crystalline, liquid or tablet forms. Each should be used according to instructions on the package label. Frequency of fertilizer application varies somewhat with the vigor of growth, age of the plant and environmental conditions. Some plants need it every two weeks, while others will grow and/or flower well for several months without needing any supplement. As a general rule, fertilize every two weeks from March to September. During the winter months, no fertilizer is needed because reduced light and temperature result in reduced growth. Fertilizing at this time could be detrimental to some plants.

Soluble Salts – Reduced growth, brown leaf tips, dropping of lower leaves, small new growth, dead root tips and wilting are all signs of high soluble salts. These salts will accumulate on top of the potting substrate, forming a yellow to white crust.

A ring of salt deposits may be formed around the pot at the soil line or around the drainage hole. Salts will also build up on the outside of clay pots.

Soluble salts are minerals dissolved in water. Fertilizer dissolved in water becomes a soluble salt. When water evaporates from the substrate, the minerals or salts stay behind. As the salts in the substrate become more and more concentrated, plants find it harder and harder to take up water. If salts build to an extremely high level, water can be taken out of the root tips, causing them to die.

High soluble salts damage the roots directly, and because the plant is weakened, it is more susceptible to attack from insects and diseases. One of the most common problems associated with high salt levels is root rot. The best way to prevent soluble salt injury is to prevent the salts from building up. Water correctly. When watering, allow some water to drain through, then empty the drip plate. Water equal to 1/10 the volume of the pot should drain through each time. **DO NOT ALLOW THE POT TO SIT IN WATER.** If the drained water is left, then absorbed by the substrate, the salts that were washed out are taken back into the substrate. Salts can be reabsorbed through the drainage hole or directly through a clay pot.

Plants should be leached every four to six months. Leach a plant before fertilizing, so new fertilizer isn't washed away. Leaching is accomplished by watering the substrate and letting it drain completely. This watering and draining cycle should be performed three times for proper leaching. The amount of water used for leaching should equal twice the volume of the pot. Keep the water running through the substrate to wash the salts out. If a layer of salts has formed a crust on top of the substrate, remove the salt crust before beginning the leaching process. Replenish the pot with fresh potting substrate. If the soluble salt level is extremely high or the pot has no drainage, repot the plant.

The level of salts that cause injury varies with the type of plant and how it is being grown. Salts at concentrations of 200 ppm may injure a plant grown in the home. Some nurseries and plant shops leach plants to remove excess salts before the plant is sold. If unsure that has been done, leach a newly purchased plant the first time it is watered.

Substrate

The potting substrate or medium in which a plant grows must be of good quality. It should be porous for root aeration and drainage, but also capable of water and nutrient retention. Most commercially prepared mixes are termed soil-less, which means they contain no soil. High-quality soil-less mixes may contain slow-release fertilizers, which take care of a plant's nutritional requirement for several months.

Preparing Soil-less Mixes – Soil-less potting substrates can be easily prepared. Most mixes contain a combination of organic matter, such as peat moss or ground pine bark and an inorganic material, like washed sand, vermiculite or perlite. Materials commonly used for indoor plants are the peat-lite mixtures, consisting of peat moss and either vermiculite or perlite. Here are some comments concerning the ingredients for these mixes.

Peat moss is readily available baled or bagged; sphagnum peat moss is recommended. Such material as Michigan peat, peat humus and native peat are usually too decomposed to provide necessary structural and drainage characteristics. Most sphagnum peat moss is acid in reaction, with a pH ranging from 4.0 to 5.0. It usually has a very low fertility level. Do not shred sphagnum peat moss too finely.

Vermiculite is a sterile, lightweight mica product. When mica is heated to approximately 1,800 F, its plate-like structure expands. Vermiculite will hold large quantities of air, water and nutrients needed for plant growth. Its pH is usually in the 6.5 to 7.2 range. Vermiculite is available in four particle sizes. For horticultural mixes, sizes two or three are generally used. If at all possible, the larger-sized particles should be used, since they give much better soil aeration. Vermiculite is available under a variety of trade names.

Perlite is sterile material produced by heating volcanic rock to approximately 1,800 F. The result is a very lightweight, porous material that is white in color. Its principal value in soil mixtures is aeration. It does not hold water and nutrients as well as vermiculite. The pH is usually between 7.0 and 7.5. Perlite can be high in fluoride and cause leaf tips to die. The burn progresses from the tip up into the leaf. A good formula for a soil-less mix follows.

1 bushel shredded peat moss
2 bushels perlite or vermiculite
½ cup finely ground agricultural lime
1/3 cup 20 percent superphosphate
½ cup 8-8-8 or similar analysis mixed fertilizer
1 level teaspoon chelated iron

Soil-less mixtures are usually very low in trace or minor elements; therefore, it is important to use a fertilizer containing these trace elements.

Potting Mixes for Specific Plants – Substrates must have the most appropriate composition for the type of plant to be grown. The mix given above is appropriate for most indoor plants, but there are some exceptions.

Cacti and Succulents: This soil does not need any humus material. It is composed of equal parts of sand, garden soil and vermiculite or perlite. It is preferred for cacti and other fleshy leaved, desert-type succulents.

Orchids: Fir-tree bark or long fiber sphagnum moss is generally used in terra cotta or plastic pots. The container should be large enough so new growth is 1 to 2 inches from the container rim. Broken clay pieces can make up the lower inch in the container.

Any potting medium containing garden loam, soil and/or sand must be pasteurized. This can be done easily at home. Spread the soil on a cookie tray and bake it at 180 F for 30 minutes. Do not heat it longer than 30 minutes. Be aware that it will smell unpleasant while baking.

Containers

There are many types of containers from which to choose. A good container should be large enough to provide room for substrate and roots, have sufficient head room for proper watering, provide bottom drainage and be attractive without competing with the plant it holds. Containers may be fabricated of ceramics, plastic, fiberglass, wood, aluminum, copper, brass and many other materials.

Unglazed and glazed porous clay pots with drainage holes are widely used. Ornate containers are often nothing but an outer shell to cover the plain clay pot. Clay pots absorb and lose moisture through their walls. Frequently, the greatest accumulation of roots is next to the wall of the clay pot because moisture and nutrients accumulate in

the clay pores and oxygen is more available than in the middle. Although easily broken, clay pots provide excellent aeration for plant roots and are considered by some to be the healthiest type of container.

Ceramic pots are usually glazed on the outside and sometimes the inside. They are frequently designed without drainage holes. This necessitates careful watering practices and does not allow for leaching. Small novelty containers have little room for potting medium and roots so are mostly for ornamental purposes. They should be avoided. It should be noted that putting pot chips, clay potshards or gravel in the bottom of a pot does not improve drainage!

Plastic and fiberglass containers are usually quite light and easy to handle. They have become popular in recent years because they are relatively inexpensive and often quite attractive in shape and color. Plastic pots are easy to sterilize or clean for reuse, and because they are not porous, they need less frequent watering and tend to accumulate fewer salts.

Repotting

Actively growing indoor plants need repotting from time to time. This occurs very rarely with some slower-growing plants, more frequently with faster-growing plants. Foliage plants require repotting when their roots have filled the pot and are growing out the bottom.

When repotting becomes necessary, it should be done without delay. The pot selected for repot-



Figure 6.60. Repot plants when roots have filled the pot and are growing out of the bottom.



Figure 6.61. Repotting a plant.



Figure 6.62. Plants can be removed easily from their pots by turning it upside down and tapping the lip of the container on the edge of a table.

ting should be no more than 2 inches larger in diameter than the pot the plant is currently growing in; should have at least one drainage hole; may be either clay, ceramic or plastic; and must be clean. Wash soluble salts from clay pots with water and a scrub brush, and wash all pots in a solution of one part liquid bleach to nine parts water. Rinse off the bleach solution thoroughly prior to using the container.

The potting medium should be coarse enough to allow good drainage, yet have sufficient water retention capabilities. Most plants are removed easily from their pot if the pot is held upside-down while knocking the lip of the container sharply upon the edge of a table. Hold your hand over the soil, straddling the plant between the fore and middle fingers while knocking it out of its present container.

The potting medium should be moistened before repotting begins. To repot, place some new substrate in the bottom of the pot. If the plant has become root-bound, it will be necessary to cut and unwind roots that encircle the plant, otherwise the roots may girdle the plant. If the old potting medium's surface has accumulated salts, the top inch should be removed. Set the rootball in the middle of the new substrate, then add substrate around the sides between the rootball and pot. Do not add substrate above the original level of the rootball unless the roots are exposed or it has been necessary to remove some of the surface potting medium. Do not pack the substrate. To fill or settle it, gently tap the pot on a level surface.

After watering and settling, the potting medium should be sufficiently below the top of the pot to leave headroom. Headroom is the space above the substrate to the top of the pot. A properly potted plant has enough headroom to allow water to wash through the potting medium, thoroughly moistening it.

Training and Grooming

Training and grooming plants include a number of minor care activities. Pinching is one of them. Pinching is the removal of 1 inch or less of new stem and leaf growth, just above a node. This leaves the plant attractive and stimulates new



Figure 6.63. Pinching helps keep plants compact.

growth. It can be a one-time or repeated activity, depending on the need of the plant and the desires of the plant owner. If a plant should be kept compact, but well-filled out, frequent pinching will achieve this.

1. A leggy plant needs to grow bushier, keeping a more compact form.
2. Pinch out growing tip of tallest stem, removing it close to leaf axil.
3. New growth forms just below pinched-out tip, making plant bushy.

Pruning is a similar activity. Pruning includes removal of other than terminal shoot tips. Sometimes an entire branch or section of a plant should be removed for the sake of appearance.

Disbudding is another grooming activity. Certain flower buds are removed, either to obtain larger blooms from a few choice buds or to prevent flowering of a very young plant (or recently rooted cutting) that should not bear the physical drain of flowering.

Ivies and hoyas, as well as philodendron and syngonium, are frequently grown in a formal pattern. This can be easily achieved by training them on trellises. It is important to keep plants clean and neat. It not only improves the appearance of plants, but also reduces the incidence of insects and disease problems. Remove all spent flowers, dying leaves and dead branches. Keep leaves dust-free by washing plants with warm water. If tips of leaves become brown and dry, trim them off neatly with sharp scissors.

Care of Special Potted Plants

Too little light, excessive heat and/or improper watering are usual causes of failure in caring for gift plants. These plants are grown in a greenhouse, where the air is moist, the night temperatures are usually cool and ample light is available. When they are brought into a dry home, where the light is poor and the temperatures are maintained for human comfort, results are frequently disappointing. Do not expect to keep a gift plant from year to year. Enjoy them while they are attractive and in season, then discard. Gardeners frequently ask if poinsettias can be held over to bloom again next year. It is questionable whether the results are worth the effort, as the quality of homegrown plants seldom equals that of commercially grown plants.

African Violet

African violets are excellent indoor flowering plants. Available in many flower colors, they produce flowers year-round with the proper growing conditions. Individual flower clusters may last three to six weeks. Poor flowering is often related to insufficient light. East- and west-facing windowsills are the best locations for violets. African violets are highly subject to root and crown rot if overwatered. Use only warm water, as cold water causes spots on leaves. Buy only high-quality plants because African violet pests and diseases spread very easily among other violets. Be especially watchful for crinkled tight crowns, a possible sign of incurable cyclamen mites. Mealy bugs can also infest African violets.

Amaryllis

The secret of growing amaryllis is to keep the plants actively growing after they finish blooming. Keep the plants in full sun, with a night temperature above 60 F. As soon as danger of frost has passed, set the plants in the garden in a semi-shaded spot. In the fall, before danger of frost returns, bring them inside, stop watering them to allow old growth to die back, and store them in a cool, dark place to rest. They will be ready to force again about November 1. Bring them into a warm, light room and water moderately to begin new growth.

Azaleas

Azaleas require direct sunlight to remain healthy. A night temperature of 60 F will prolong bloom. Keep the potting medium evenly moist. If the leaves should turn yellow, the potting medium may not be acid enough. Use an acid fertilizer sold especially for azaleas. Do not use softened water. When repotting, use a mixture high in acid peat moss.

Azaleas can be planted, pot and all, in a shady spot in the garden during the summer months. Examine them frequently and keep them watered during dry periods. Greenhouse azaleas are not hardy and need to be brought indoors before freezing weather.

Azaleas need a cool, rest treatment before they are forced into bloom. Place the plants in a room with filtered light and a temperature between 35 F and 50 F to break flower bud dormancy. During this rest period, flower buds will develop. Return the plants to a well-lit, warm (65 F) room around January 1 to bring them into bloom. Unless the proper growing conditions for the azalea are available, do not attempt to carry the plants to the next year.

Christmas Pepper

Christmas pepper plants are bought for the highly decorative fruit and are usually available in four- and six-inch pots during the fall and winter. The fruit will be at peak color for one to two months. They will be brighter and last longer if provided high light and mild temperatures (60 F to 75 F) and the potting medium is kept moist. Fertilize weekly with a soluble fertilizer. Be aware that these peppers are sometimes extremely hot. Keep them away from small children. (It is also very hard to rebloom Christmas pepper). Frost will kill the plants.

Chrysanthemum

Two types of mums are sold at retail outlets: florist mums and garden mums. Garden mums are generally available in the fall as a potted flowering plant. They can be planted outdoors and are hardy through the winter. Garden mums are perennial and will flower each year. Florist mums are greenhouse varieties available year-round; they provide three to four weeks of enjoyment. Florist mums can be planted into the garden, where they will easily perennialize. Buy florist mums when flower buds are just beginning to show color. Diffuse, bright

light levels and 60 F to 70 F temperatures will prolong peak bloom. Don't let the plants wilt.

Cyclamen

Cyclamen plants require full sunlight and a night temperature of between 50 F and 60 F. They prefer to be kept evenly moist. Flower buds will fail to develop if night temperature is too high or if light is poor.

Cyclamen can be carried over, but as with the poinsettia, homegrown plants are seldom equal to those grown by a commercial grower. Let the plants enter dormancy after they finish flowering by limiting water. Allow the dormant tuber to dry, but not to become shriveled. Repot the fleshy tuber in June with the top of it just above the potting medium.

Easter Lily

Easter lilies are produced specifically for the Easter season. Choose strong-stemmed plants with even, regular foliage and four or more flower buds. Cool household temperatures (60 F) to prolong flowering. Remove yellow anthers before the pollen is shed to make the flower last longer and to keep the pollen from staining the pristine white petals. Easter lilies can be transplanted outdoors in most areas in Oklahoma and will often rebloom the following June. It's difficult to reflower bulbs kept in pots.

Foliage Plants

Foliage plants have varying light, temperature and watering requirements. For example, Chinese evergreen plants do well in low light, but dieffenbachia require medium to high light. Most can be damaged by temperatures below 55 F. Ideal temperatures for growth are 75 F to 95 F. Ask the local county Extension educator or nursery person, or consult a plant book for the recommended light level for specific plants.

From time to time, clean the leaves to remove dust. Foliage plants can be rejuvenated by placing them in a shaded area outdoors during warm weather. Avoid placing them near windows or doors during winter where there might be cold drafts.

Forced Spring Bulbs

Forced bulbs are geophytes such as tulips, daffodils, crocuses and hyacinths that are exposed to

chilling temperatures in a cooler or refrigerator for several weeks, then placed in warm greenhouses so the flowers will develop.

To get the most color and greatest longevity from potted spring bulbs, buy plants when the flower buds first show color. In most cases, the buds will open in one or two days. To slow flower development and make the blooms last longer, keep plants cool. They will tolerate temperatures as low as 40 F. Keep plants evenly moist, as water stress can reduce the flowering time in half. It's not necessary to fertilize since the plant's useful life is two to four weeks. The bulbs may be replanted outdoors and may reflower after a year or two.

Gardenia

Gardenias grown indoors need special care. They require an acidic potting medium and should receive the same nutritional care as azaleas. The night temperature should be near 60 F, and the humidity around the plant should be kept high. High temperature and low light intensity will result in flower bud drop.

Geranium

Potted geraniums are typically available from March through June. Many new types are available, including vining and hanging basket grown varieties. Bright light is essential to keep geraniums in flower year-round. Keep them in pots or transplant them into the landscape once the danger of frost has passed. They are not winter hardy and must be brought inside before frost if you want to keep them. Geraniums respond favorably to having the potting medium slightly dry between thorough waterings.

Gloxinia

Gloxinias are very similar to African violets in the way care is given. They may be available in florist shops year-round. Bright, indirect light is necessary to keep the plant in flower. Gloxinias typically flower for two to four weeks. Individual blooms last four to six days. Unlike African violets, gloxinias need to rest before reflowering. Reduce watering when the leaves start to die back. Allow the tubers to rest two to four months in dry soil. To get the plant to reflower (although difficult), resume watering when new growth appears.

Holiday Cactus

The holiday cactus has become increasingly popular with the development of several new varieties. At least three related species are sold in addition to a number of cultivars. All have similar cultural requirements.

The secret of good bloom is one of temperature and photoperiod control. They will develop buds and bloom if given bright light, short days and night temperatures between 55 F and 65 F. Holiday cacti bloom best when somewhat pot-bound. Repotting is necessary only about once every three years. Full sunlight is beneficial in mid-winter, but bright sun during summer months can make plants look pale.

Holiday cacti require less water from October to March than they do when growth is active from April to September. A rest period is very important if plants are to bloom abundantly. Short days (11 hours or less of light each day) should be started about the middle of September and continue for eight weeks. Care should be taken that the potting medium never becomes waterlogged during the days of winter.

Hydrangea

Hydrangeas, generally recognized as an outdoor flowering shrub, are also available as six- and eight-inch potted flowering plants. They are grown to flower for the spring holiday season. Blooms can last from four to eight weeks if plants are bought as color first develops, watered adequately and kept at mild temperatures (65 F to 80 F) and medium light intensity. After the flowers fade, remove the flower heads and transplant the plants into the landscape.

Kalanchoe

Kalanchoes are available year-round in many colors. Flowers will last three to six weeks in mild temperatures (65 F to 80 F) and medium light, if the plants are kept watered. Using manufacturers' recommended levels of houseplant fertilizer once a month helps. The plants will rebloom if exposed to short days (long nights) for six to eight weeks. They can be grown successfully if kept in sunny windows or placed outdoors in late spring.

Poinsettia

The colorful bracts of poinsettias may stay bright for months if cared for properly. Some of the newer, long-lasting varieties can be kept attractive all winter. Bright, indirect light and frequent watering are essential. Keep plants away from drafts. Don't allow the plants to wilt, but rather allow the potting medium to nearly dry between thorough waterings.

Plants can be reflowered, although the procedure is somewhat demanding. For those who wish to try, the following procedure can be followed.

After the bracts fade or fall, set the plants where they will receive bright sunlight and temperatures around 65 F to 70 F. Cut the plants back to within five inches of the potting medium. Water sparingly during this time, just enough to keep the stems from shriveling. Keep the plant indoors until the danger of frost has passed, then move it outdoors to a partially shaded spot. Water and fertilize often. Shape the plant as desired. Prune it or pinch it to encourage branching. Do not pinch after September 1. As soon as the nights are cool, bring the plant back indoors. Continue to grow in a sunny room with a night temperature of about 68 F. Starting mid-September, give the plant a minimum of 12 hours continuous darkness every night until bract color is well developed (mid-November). This can be done by placing the plant in a closet or covering it with a cardboard box. Any light during the dark period will delay or prevent flowering. Plants require full light in the daytime, so be sure to return them to a sunny window. Night temperatures at this time should be between 65 F and 70 F.

Orchids

Most orchids are easily cared for if kept away from intense light and cold. Many do very well under fluorescent lights or near windows. Most orchids bloom only once a year, but the blooms can last as long as two months. Fertilize during active growth with a complete fertilizer. Water often, but allow the potting medium to dry between thorough waterings. Orchids can be grown outdoors under the shade of trees after the danger of frost has passed.

Plants List

The remainder of this section is composed of lists of plants that will withstand specific indoor conditions of light intensity, temperature and cultural form. Table 6.13 at the end of the chapter tells how to diagnose symptoms of common diseases, insects and pests on indoor plants.

Table 6.10. Indoor plants for low, medium and high light locations.*Scientific Name**Common Name***Low Light (25 to 75 footcandles)**

<i>Aglaonema commutatum</i>	Silver Chinese Evergreen
<i>Aglaonema commutatum</i> 'Silver King'	Silver King Evergreen
<i>Aglaonema modestum</i>	Chinese Evergreen
<i>Aspidistra elatior</i>	Cast-Iron Plant
<i>Aspidistra elatior</i> 'Variegata'	Variegated Cast-Iron Plant
<i>Chamaedorea elegans</i>	Parlor Palm
<i>Chamaedorea elegans</i> 'Bella'	Dwarf Parlor Palm
<i>Epipremnum aureum</i>	Golden Pothos
<i>Epipremnum aureum</i> 'Marble Queen'	Marble Queen Pothos
<i>Monstera deliciosa</i>	Split-Leaf Philodendron, Swiss-cheese Plant
<i>Sansevieria trifasciata</i>	Snake Plant, Mother-in-law's Tongue
<i>Sansevieria trifasciata</i> 'Laurentii'	Goldenstripe, Goldband Sansevieria

Medium Light (75 to 150 footcandles)

<i>Aechmea fasciata</i>	Silver Vase
<i>Aglaonema commutatum</i> 'White Rajah'	White Rajah Aglaonema
<i>Asparagus densiflorus</i> 'Myers'	Plume Asparagus
<i>Asparagus densiflorus</i> Sprengeri Group	Sprengeri Asparagus
<i>Asparagus setaceus</i>	Fern Asparagus
<i>Aucuba japonica</i> 'Variegata'	Gold-Dust Plant
<i>Chamaedorea erumpens</i> *	Bamboo Palm
<i>Chlorophytum comosum</i> 'Variegatum'	Spider Plant
<i>Cissus rhombifolia</i>	Grape Ivy
<i>Dieffenbachia amoena</i>	Giant Dumb cane
<i>Dieffenbachia amoena</i> 'Exotica'	Exotica Dumb cane
<i>Dieffenbachia maculata</i>	Spotted Dumb cane
<i>Dieffenbachia maculata</i> 'Rudolph Roehrs'	Gold Dieffenbachia
<i>Dizygotheca elegantissima</i>	False Aralia
<i>Dracaena deremensis</i> 'Warneckii'	Striped Dracaena
<i>Dracaena fragrans</i> 'Massangeana'	Corn Plant
<i>Dracaena godseffiana</i> *	Gold-Dust Dracaena
<i>Dracaena marginata</i> *	Red-Margined Dracaena
<i>Dracaena sanderana</i> *	Ribbon Plant
<i>Fatsia japonica</i>	Japanese Fatsia
<i>Ficus benjamina</i>	Weeping Fig
<i>Ficus elastica</i> 'Decora'	India Rubber Tree

*May also be conditioned to grow in low light.

Table 6.10. Indoor plants for low, medium and high light locations. (cont'd)

<i>Scientific Name</i>	<i>Common Name</i>
<i>Ficus lyrata</i>	Fiddle-Leaf Fig
<i>Ficus microcarpa</i>	Indian Laurel
<i>Gynura aurantiaca</i>	Velvet Plant
<i>Hedera helix</i> & cvs	English Ivy
<i>Howea forsteriana</i>	Kentia Palm
<i>Maranta leuconeura erythroneura</i>	Red-Veined Prayer Plant
<i>Nephrolepis exaltata</i> 'Bostoniensis'	Boston Fern
<i>Pandanus veitchii</i>	Variiegated Screw Pine
<i>Peperomia caperata</i> *	Emerald Ripple Peperomia
<i>Peperomia obtusifolia</i>	Oval-Leaf Peperomia
<i>Peperomia obtusifolia</i> 'Variegata'	Variiegated Oval-Leaf Peperomia
<i>Philodendron bipennifolium</i> *	Fiddle-Leaf Philodendron
<i>Philodendron bipinnatifidum</i>	Tree Philodendron
<i>Philodendron scandens</i> ssp. <i>oxycardium</i> *	Heart-Leaf Philodendron
<i>Pilea cadierei</i>	Aluminum Plant
<i>Pilea involucrata</i>	Artillery Plant, Friendship Plant
<i>Plectranthus australis</i>	Swedish Ivy
<i>Polyscias scutellaria</i> 'Balfourii'	Balfour Aralia
<i>Saintpaulia</i> spp., hybrids & cvs.	African Violet
<i>Schefflera actinophylla</i> *	Schefflera
<i>Schefflera arboricola</i> *	Dwarf Schefflera
<i>Spathiphyllum</i> 'Clevelandii'	Cleveland Peace Lily
<i>Spathiphyllum floribundum</i> 'Mauna Loa'	Mauna Loa Peace Lily
<i>Syngonium podophyllum</i> 'Trileaf Wonder'	Trileaf Wonder Syngonium
<i>Tradescantia fluminensis</i>	Inch Plant
<i>Tradescantia zebrina</i>	Wandering Jew

High Light (150 to 1,000 footcandles)

<i>Aloe vera</i>	Aloe Vera
<i>Alternanthera ficoidea</i>	Joseph's Coat
<i>Araucaria heterophylla</i>	Norfolk Island Pine
<i>Cissus antarctica</i> **	Kangaroo Vine
<i>Crassula ovata</i>	Jade Plant
X <i>Fatshedera lizei</i> **	Botanical Wonder
<i>Hibiscus rosa-sinensis</i>	Chinese Hibiscus
<i>Hoya carnosa</i> **	Wax Plant
<i>Iresine lindenii</i>	Blood Leaf
<i>Nolina recurvata</i>	Ponytail Palm
<i>Podocarpus gracilior</i>	Weeping Podocarpus
<i>Sedum morganianum</i>	Burro's or Donkey's Tail
<i>Solenostemon scutellarioides</i>	Coleus
<i>Tradescantia spathacea</i>	Moses-In-The-Cradle

*May also be conditioned to grow in low light.

**May also be conditioned to grow in medium light.

Table 6.11. Temperature Requirements of Selected Indoor Plants

Cool temperature plants grow best at 50 F to 60 F during the day and 50 F to 55 F at night.

Azalea
Cacti and Succulents^{2,3}
(during winter rest periods only)
Camellia
Cast-Iron Plant²
Chrysanthemum
Citrus (grapefruit, lemon, orange)
Creeping Fig
Daffodil, Narcissus
Easter Lily²
Euonymus japonicus (Spindle Tree)
Ivy²
Hyacinth
Hydrangea
Japanese Aralia
Jasmine
Jerusalem Cherry
Miniature Rose
Mock Orange
Norfolk Island Pine
Persian Violet
Primrose
Tulip
Tree Ivy
Wandering Jew
White Calla Lily
Zephyr Lily

Medium temperature plants grow best at 60 F to 65 F during the day and 55 F to 60 F at night.

Amaryllis
Asparagus Fern
Avocado
Baby's Tear
Begonia
Birds' Nest Fern
Bromeliads³
Bush Violet
Cacti and Succulents^{1,3}
Cast-Iron Plant¹
Christmas Cactus
Citrus¹
Coleus
Crown of Thorns³
Earth Star³
Easter Lily¹
English Ivy¹
German Ivy
Gold-Dust Tree
Hibiscus
Kangaroo Vine³

Living Stones³
Palms
Panda Plant
Peperomia
Piggyback Plant
Pilea
Podocarpus
Purple Passion Plant
Schefflera
Shamrock Plant
Snake Plant³
Staghorn Fern³
Strawberry Begonia
Wax Plant

¹ Will also do well at high temperatures.
² Will also do well at medium temperatures.
³ Will also do well at cool temperatures.

High temperature plants grow best at 70 F to 80 F during the day and 64 F to 70 F at night.

African Violets
Bromeliads
Cacti and Succulents^{1,2}
Caladium calathea (Peacock Plant)
Chinese Evergreen
Coconut Palm
Copperleaf
Cordyline
Croton
Crown of Thorns²
Dracaena
Earth Star²
False Aralia
Ficus
Flame Violet
Geranium
Golden Pothos
Hens and Chicks
Impatiens
Kangaroo Vine²
Living Stones²
Peace Lily
Philodendron
Prayer Plant
Purple Velvet Plant²
Sensitive Plant
Snake Plant
Staghorn Fern²
Swiss Cheese Plant
Screw Pine

¹ Will also do well at high temperatures.
² Will also do well at medium temperatures.

Table 6.12. Plants for Specific Indoor Gardening Uses

<i>Scientific Name</i>	<i>Common Name</i>
Plants that will grow in water:	
<i>Aglaonema modestum</i>	Chinese Evergreen
<i>Crassula arborescens</i>	Jade Plant
<i>Dieffenbachia</i> (all varieties)	Dumb cane
<i>Epipremnum aureum</i>	Devil's Ivy
<i>Hedera helix</i>	English Ivy
<i>Hemigraphis alternata</i>	Red Ivy, Hemigraphis
<i>Hoya carnosa</i>	Wax Plant
<i>Monstera deliciosa</i>	Cutleaf Philodendron, Swiss-cheese Plant
<i>Pellionia pulchra</i>	Satin Pellionia, Rainbow Vine
<i>Philodendron cordatum</i>	Heartleaf Philodendron
<i>Philodendron scandens</i> ssp. <i>scandens</i> f. <i>micans</i>	(All climbing types)
<i>Piper nigrum</i>	Black Pepper
<i>Piper ornatum</i>	Celebes Pepper
<i>Scindapsus pictus</i>	Painted Devil's Ivy
<i>Stephanotis floribunda</i>	Bridal Wreath, Waxflower, Stephanotis
<i>Syngonium podophyllum</i>	Arrowhead Vine or Syngonium
<i>Tradescantia</i> (all varieties)	Wandering Jew

Plants that will usually withstand adverse house conditions and abuse:

<i>Aglaonema modestum</i>	Chinese Evergreen
<i>Anthurium pentaphyllum</i> var. <i>bombacifolium</i>	Climbing Anthurium
<i>Aspidistra elatior</i>	Cast-Iron Plant
<i>Chamaedorea elegans</i> 'Bella'	Dwarf Parlor Palm
<i>Cissus rhombifolia</i>	Grape Ivy
<i>Crassula arborescens</i>	Jade Plant
<i>Dieffenbachia amoena</i>	Dumb Cane
<i>Dracaena fragrans</i> 'Massangeana'	Massange Dracaena
<i>Epipremnum aureum</i>	Devil's Ivy
<i>Euphorbia milii</i>	Crown of Thorns
<i>Ficus benjamina</i> 'Exotica'	Java Fig
<i>Ficus elastica</i>	India Rubber Tree
<i>Hemigraphis alternata</i>	Red Ivy, Hemigraphis
<i>Howea belmoreana</i>	Belmore Sentry Palm
<i>Pandanus veitchii</i>	Screw Pine
<i>Peperomia obtusifolia</i>	Oval-Leaf Peperomia
<i>Philodendron cordatum</i>	Heartleaf Philodendron
<i>Sansevieria trifasciata</i>	Snake Plant, Mother-in-law's Tongue
<i>Sansevieria trifasciata</i> 'Laurentii'	Goldenstripe, Goldband Sansevieria
<i>Syngonium podophyllum</i>	Arrowhead Vine or Syngonium

Plants that perform well with average home conditions:

<i>Acanthus montanus</i>	Mountain Acanthus
<i>Aechmea calyculata</i>	Bromeliad
<i>Aechmea orlandiana</i>	Bromeliad
<i>Araucaria heterophylla</i>	Norfolk Island Pine
<i>Asparagus densiflorus</i> Sprengeri Group	Sprengeri Asparagus
<i>Begonia aconitifolia</i>	Begonia
<i>Begonia ulmifolia</i>	Elm-Leaf Begonia
<i>Caladium bicolor</i>	Fancy-Leaved Caladium
<i>Cissus antarctica</i>	Kangaroo Vine
<i>Cissus rhombifolia</i>	Grape Ivy
<i>Cordyline australis</i>	Grass Palm
<i>Cryptanthus acaulis</i>	Earth Star
<i>Cyrtomium falcatum</i>	Japanese Holly Fern
<i>Dieffenbachia bausei</i>	Dumb Cane
<i>Dieffenbachia picta</i>	Dumb Cane
<i>Epipremnum aureum</i>	Devil's Ivy
<i>Euphorbia milii</i>	Crown of Thorns
<i>Fatsia japonica</i>	Japanese Fatsia
X <i>Fatshedera lizei</i>	Botanical Wonder
<i>Ficus benghalensis</i>	Banyan Fig
<i>Ficus religiosa</i>	Bo-Tree Fig
<i>Ficus septica</i>	Ivory Fig
<i>Grevillea robusta</i>	Silky Oak
<i>Hedera helix</i> (all varieties)	English Ivy
<i>Justicia brandegeana</i>	Shrimp Plant
<i>Pedilanthus tithymaloides</i>	Slipper or Red Bird Flower
<i>Peperomia argyreia</i>	Watermelon Peperomia
<i>Peperomia clusiifolia</i>	Red-edge Peperomia
<i>Peperomia crassifolia</i>	Leather Peperomia
<i>Peperomia obtusifolia</i> 'Variegata'	Variegated Oval-Leaf Peperomia
<i>Pereskia aculeata</i>	Lemon Vine
<i>Philodendron bipinnatifidum</i>	Tree Philodendron
<i>Philodendron cordatum</i>	Heartleaf Philodendron
<i>Philodendron dubium</i>	Philodendron
<i>Philodendron erubescens</i>	Red-Leaf Philodendron
<i>Philodendron giganteum</i>	Giant Philodendron
<i>Philodendron imbe</i>	Imbe Philodendron
<i>Philodendron</i> 'Mandaianum'	Philodendron
<i>Philodendron panduriforme</i>	Panda Plant
<i>Philodendron tripartitum</i>	Trileaf Philodendron
<i>Philodendron wendlandii</i>	Philodendron
<i>Pilea involucrata</i>	Artillery Plant, Friendship Plant
<i>Piper nigrum</i>	Black Pepper
<i>Piper ornatum</i>	Celebes Pepper
<i>Polyscias filicifolia</i>	Fern-Leaf Aralia
<i>Polyscias paniculata</i> 'Variegata'	Jagged-Leaf Aralia
<i>Polyscias scutellaria</i> 'Balfourii'	Balfour Aralia
<i>Sansevieria parva</i>	Parva Sansevieria
<i>Sansevieria subspicata</i>	Red-edge Sansevieria

<i>Sansevieria trifasciata</i> 'Hahnii'	Hahn's Sansevieria
<i>Saxifraga stolonifera</i>	Strawberry Geranium
<i>Schismatoglottis picta</i>	Painted Tongue
<i>Spathiphyllum</i> 'Clevelandii'	Cleveland Peace Lily
<i>Syngonium podophyllum</i> 'Emerald Gem'	Variegated Arrowhead
<i>Tradescantia</i> (all varieties)	Wandering Jew
<i>Tradescantia spathacea</i>	Moses-In-The-Cradle

Plants well-suited for decorative large containers:

<i>Acanthus mollis</i>	Artists Acanthus
<i>Acanthus montanus</i>	Mountain Acanthus
<i>Alocasia cuprea</i>	Giant Caladium
<i>Codiaeum variegatum</i> var. <i>pictum</i>	Croton
<i>Cyathia australis</i>	Australian Tree Fern
<i>Dieffenbachia amoena</i>	Spotted Dumb Cane
X <i>Fatshedera lizei</i>	Botanical Wonder
<i>Fatsia japonica</i>	Japan Fatsia
<i>Ficus elastica</i> 'Variegata'	Variegated India Rubber
<i>Ficus lyrata</i>	Fiddle-Leaf Fig
<i>Ficus septica</i>	Ivory Fig
<i>Monstera deliciosa</i>	Cutleaf Philodendron, Swiss-cheese Plant
<i>Pandanus veitchii</i>	Screw Pine
<i>Philodendron bipinnatifidum</i>	Tree Philodendron
<i>Philodendron elongatum</i>	Philodendron
<i>Philodendron giganteum</i>	Giant Philodendron
<i>Philodendron</i> 'Mandaianum'	Philodendron
<i>Philodendron panduriforme</i>	Panda Plant
<i>Philodendron wendlandii</i>	Philodendron
<i>Polyscias paniculata</i> 'Variegata'	Jagged-Leaf Aralia
<i>Schefflera digitata</i>	Schefflera
<i>Strelitzia reginae</i>	Bird of Paradise

Low, creeping plants suitable for ground covers in interior planting boxes:

<i>Epipremnum aureum</i>	Devil's Ivy
<i>Episcia cupreata</i>	Flame Violet
<i>Ficus pumila</i>	Creeping Fig
<i>Ficus sagittata</i>	Climbing Fig
<i>Fittonia verschaffeltii</i> var. <i>argyroneura</i>	Silver Fittonia, Silver Nerve Fittonia
<i>Hedera helix</i>	Hahn's Star English Ivy
<i>Hemigraphis alternata</i>	Red Ivy, Hemigraphis
<i>Pellionia repens</i>	Pellionia, Trailing Watermelon Vine
<i>Pellionia pulchra</i>	Satin Pellionia, Rainbow Vine
<i>Philodendron cordatum</i>	Heartleaf Philodendron
<i>Pilea nummulariifolia</i>	Creeping Charlie, Creeping Artillery Plant
<i>Saxifraga stolonifera</i>	Strawberry Geranium
<i>Tradescantia</i> (all varieties)	Wandering Jew
<i>Vinca major</i> 'Variegata'	Variegated Vinca

Plants that withstand dry, warm locations:

Bromeliads	All species and varieties
Cacti	All species and varieties

Vines and trailing plants for totem poles and trained plants:

<i>Anthurium pentaphyllum</i> var. <i>bombacifolium</i>	Climbing Anthurium
<i>Cissus antarctica</i>	Kangaroo Vine
<i>Cissus discolor</i>	Rex Begonia Vine
<i>Cissus rhombifolia</i>	Grape Ivy
<i>Clerodendrum balfourii</i>	Glory-bower
<i>Ficus pumila</i>	Creeping Fig
<i>Vanilla planifolia</i> 'Marginata'	Vanilla

Plants suitable for hanging baskets:

<i>Achimenes grandiflora</i>	Big Purple Achimenes
<i>Aeschynanthus parasiticus</i>	Lobecup Basket Vine
<i>Aeschynanthus parasiticus</i> 'Black Pagoda'	Black Pagoda Basket Vine
<i>Aeschynanthus pulcher</i>	Scarlet Basket Vine
<i>Aeschynanthus radicans</i>	Lipstick Plant
<i>Alsobia dianthiflora</i>	Lace Flower Vine
<i>Asarina erubescens</i>	Creeping Gloxinia
<i>Asparagus densiflorus</i> Sprengeri Group	Sprengeri Asparagus
<i>Asparagus setaceus</i>	Fern Asparagus
<i>Begonia X hiemalis</i>	Winter Flowering Begonia
<i>Begonia X hiemalis</i> 'Elsie M. Frey'	Winter Flowering Begonia
<i>Callisia elegans</i>	Striped Inch Plant
<i>Ceropegia linearis</i> ssp. <i>woodii</i>	String of Hearts, Rosary Vine
<i>Chlorophytum bichetii</i>	St. Bernard's Lily
<i>Chlorophytum comosum</i> 'Variegatum'	Spider Plant
<i>Cissus quadrangularis</i>	Winged Treebine
<i>Codonanthe crassifolia</i>	Central American Bellflower
<i>Columnea X banksii</i>	Goldfish Vine
<i>Columnea microphylla</i>	Small-Leaved Goldfish Vine
<i>Commelina communis</i> 'Aureostriata'	Variegated Widows Tear
<i>Cyanotis kewensis</i>	Teddy Bear Plant
<i>Cyanotis somaliensis</i>	Pussy Ear
<i>Cymbalaria muralis</i>	Kenilworth Ivy
<i>Davallia fejeensis</i> 'Plumosa'	Rabbit's Foot Fern
<i>Dendranthema X grandiflorum</i> 'Anna'	Daisy Cascade
<i>Dendranthema X grandiflorum</i> 'Jane Harte'	Daisy Cascade
<i>Epipremnum aureum</i>	Devil's Ivy
<i>Episcia cupreata</i> 'Amazon'	Amazon Flame Violet
<i>Episcia cupreata</i> 'Chocolate Soldier'	Carpet Plant
<i>Episcia cupreata</i> 'Emerald Queen'	Emerald Queen Episcia
<i>Episcia cupreata</i> 'Silver Sheen'	Silver Sheen Episcia
<i>Episcia</i> 'Ember Lace'	Ember Lace Episcia
<i>Episcia</i> 'Moss Agate'	Panama Episcia
<i>Euphorbia mammillaris</i>	Corncob Plant

<i>Fittonia verschaffeltii</i>	Mosaic Plant
<i>Fittonia verschaffeltii</i> var. <i>argyroneura</i>	Silver Fittonia, Silver Nerve Fittonia
<i>Fittonia verschaffeltii</i> var. <i>pearcei</i>	Snake Skin Plant
<i>Fuchsia</i> 'Jubilee'	Jubilee Fuchsia
<i>Fuchsia</i> 'Swingtime'	Swingtime Fuchsia
<i>Fuchsia triphylla</i> 'Gartenmeister Bohnstedt'	Honeysuckle Fuchsia
<i>Hatiora gaertneri</i>	Easter Cactus
<i>Hatiora salicornioides</i>	Bottle Cactus, Drunkard's Dream
<i>Hedera helix</i> 'Hahn's Variegated'	Variegated Hahn's English Ivy
<i>Hedera helix</i> 'Ivalace'	Ivalace English Ivy
<i>Hemigraphis alternata</i>	Red Ivy, Hemigraphis
<i>Hemigraphis</i> 'Exotica'	Waffle Plant
<i>Hoya australis</i>	Porcelain Flower, Pubescent Wax Plant
<i>Hoya carnosa</i> 'Compacta'	Compact Wax Plant
<i>Hoya carnosa</i> 'Exotica'	Exotica Wax Plant
<i>Hoya carnosa</i> 'Krinkle Kurl'	Hindu Rope Plant
<i>Hoya carnosa</i> 'Tri-color'	Variegated Wax Plant
<i>Hoya imperialis</i>	Honey Plant
<i>Hoya lanceolata</i> ssp. <i>bella</i>	Miniature Wax Plant
<i>Hoya motoskei</i>	Spotted Wax Plant
<i>Hoya purpureofusca</i>	Silver Pink Wax Plant
<i>Hoya shepherdii</i>	Shepherd's Wax Plant
<i>Hypocyrtia nummularia</i>	Miniature Pouch Flower
<i>Hylocereus undatus</i>	Night-blooming Cereus
<i>Ipomoea batatas</i>	Blackleaf Sweet Potato
<i>Kalanchoe gastonis-bonnierei</i>	Life Plant
<i>Kalanchoe manginii</i>	Mangin Kalanchoe
<i>Kalanchoe pubescens</i>	Jinglebells Kalanchoe
<i>Kalanchoe uniflora</i>	Miniature Kalanchoe
<i>Lepismium houlettianum</i>	Snowdrop Cactus
<i>Mammillaria elongata</i>	Lace Mammillaria
<i>Nephrolepis exaltata</i> 'Bostoniensis'	Boston Fern
<i>Nephrolepis exaltata</i> 'Rooseveltii'	Tall Feather Fern
<i>Pelargonium X fragrans</i>	Scented Geranium
<i>Pellionia pulchra</i>	Satin Pellionia, Rainbow Vine
<i>Pellionia repens</i>	Pellionia, Trailing Watermelon Vine
<i>Peperomia acuminata</i>	Mexico Pepperface
<i>Peperomia cubensis</i>	Cuban Pepperface
<i>Peperomia glabella</i> 'Variegata'	Variegated Waxprivet Peperomia
<i>Peristrophe hyssopifolia</i> 'Aureo-variegata'	Marble-Leaf
<i>Philodendron scandens</i> ssp. <i>oxycardium</i>	Heart-Leaf Philodendron
<i>Philodendron scandens</i> ssp. <i>scandens</i> f. <i>micans</i>	Velvet-Leaf Vine
<i>Phlebodium aureum</i>	Hare's-Foot or Rabbit's-Foot Fern
<i>Pilea nummulariifolia</i>	Creeping Charlie, Creeping Artillery Plant
<i>Platynerium bifurctum</i>	Elkhorn Fern, Staghorn Fern
<i>Plectranthus forsteri</i>	Candle Plant
<i>Plectranthus oertendahlii</i> 'Marginatus'	Prostrate Coleus
<i>Plectranthus purpuratus</i>	Moth King
<i>Plectranthus tomentosus</i>	Succulent Coleus
<i>Portulacaria afra</i> 'Variegata'	Rainbow Bush
<i>Rhipsalis baccifera</i>	Mistletoe Rhipsalis

<i>Rhipsalis capilliformis</i>	Treechair Rhipsalis
<i>Rhipsalis paradoxa</i>	Chain Cactus
<i>Rhipsalis pentaptera</i>	Fivewing Rhipsalis
<i>Rhipsalis pilocarpa</i>	Bristle-tufted Twig Cactus
<i>Rhipsalis trigona</i>	Triangle Rhipsalis
<i>Ruellia makoyana</i>	Monkey Plant
<i>Schlumbergera X buckleyi</i>	Christmas Cactus
<i>Sedum morganianum</i>	Burro's or Donkey's Tail
<i>Senecio herreianus</i>	Green Marbled vine
<i>Solenostemon scutellarioides</i> 'Trailing Queen'	Trailing Coleus
<i>Stapelia gigantea</i>	Giant Toadplant
<i>Stenotaphrum secundatum</i> 'Variegatum'	Variegated St. Augustine Grass
<i>Streptocarpus saxorum</i>	False African Violet
<i>Tradescantia albiflora</i> 'Albovittata'	Giant White Inch Plant
<i>Tradescantia pallida</i>	Purple Heart
<i>Tradescantia sillamontana</i>	White Velvet; White Gossamer

Plants suitable for tropical terrariums:

<i>Scientific Name</i>	<i>Common Name</i>
<i>Aglaonema commutatum</i>	Silver Chinese Evergreen
<i>Begonia bowerae</i>	Eyelash Begonia, Miniature Begonias
<i>Chamaedorea elegans</i>	Parlor Palm
<i>Cissus antarctica</i> 'Minima'	Dwarf Kangaroo Ivy
<i>Coffea arabica</i>	Arabian Coffee Plant
<i>Cordyline terminalis</i> 'Baby Ti'	Dwarf Ti Plant
<i>Cryptanthus bivittatus</i> 'Minor'	Dwarf Rose-Stripe Earth Star
<i>Dizygotheca elegantissima</i>	False Aralia
<i>Dracaena sanderana</i>	Belgian Evergreen
<i>Dracaena surculosa</i>	Gold Dust Dracaena
<i>Ficus deltoidea</i>	Mistletoe Fig
<i>Ficus pumila</i> 'Minima'	Dwarf Creeping Fig
<i>Fittonia verschaffeltii</i>	Mosaic Plant
<i>Maranta leuconeura</i> var. <i>kerchoviana</i>	Prayer Plant
<i>Nephrolepis exaltata</i> cvs.	Boston Fern
<i>Peperomia argyreia</i>	Watermelon Peperomia
<i>Pilea cadierei</i> 'Minima'	Dwarf Aluminum Plant
<i>Pilea depressa</i>	Miniature Pilea
<i>Pilea microphylla</i>	Artillery Plant
<i>Pilea nummulariifolia</i>	Creeping Charlie, Creeping Artillery Plant
<i>Pteris</i> spp.	Brake Ferns, Table Ferns
<i>Saintpaulia</i> cvs.	Miniature African Violets
<i>Selaginella</i>	Club Moss, Moss Fern
<i>Selaginella kraussiana</i>	Creeping Club Moss
<i>Selaginella pallescens</i>	Sweat Plant
<i>Sinningia pusilla</i> (and other miniature cultivars)	Miniature Gloxinia
<i>Syngonium podophyllum</i>	Arrowhead Vine or Syngonium

Plants suitable for desert dish gardens:

<i>Adromischus maculatus</i>	Calico Hearts, Leopard Spots
<i>Aloe</i> spp.	Medicine Plant
<i>Astrophytum myriostigma</i>	Bishop's Cap
<i>Cereus uruguayanus</i> 'Monstrosus'	Curiosity Plant
<i>Crassula</i> spp.	Jade Plant
<i>Crassula muscosa</i>	Toy Cypress, Watch Chain
<i>Crassula rupestris</i>	Rosary Vine
<i>Echeveria derenbergii</i>	Painted Lady
<i>Echeveria elegans</i>	Mexican Snowball
<i>Echeveria secunda</i> var. <i>glauca</i>	Hens and Chicks
<i>Echinocactus grusonii</i>	Golden Barrel Cactus
<i>Echinocereus pectinatus</i> var. <i>neomexicanus</i>	Rainbow Cactus
<i>Echinocereus reichenbachii</i>	Lace Cactus
<i>Epithelantha micromeris</i>	Button Cactus
<i>Euphorbia lactea</i> 'Cristata'	Crested Euphorbia, Frilled Fan
<i>Faucaria tigrina</i>	Tiger Jaws
<i>Gasteria bicolor</i> var. <i>liliputana</i>	Miniature Gasteria, Miniature Ox Tongue
<i>Haworthia</i>	Pearl Plant, Wart Plant
<i>Haworthia fasciata</i>	Zebra Haworthia
<i>Haworthia margaritifera</i>	Pearl Plant
<i>Lithops</i> spp.	Living Stones
<i>Mammillaria bocasana</i>	Powder Puff Cactus
<i>Mammillaria elongata</i>	Golden Star Cactus
<i>Mammillaria gracilis</i>	Thimble Cactus
<i>Opuntia erectoclada</i>	Dominoes, Pincushion Cactus
<i>Opuntia microdasys</i>	Bunny Ears
<i>Opuntia vilis</i>	Dwarf Tree Opuntia
<i>Pilosocereus royenii</i>	Cylinder Cactus
<i>Portulacaria afra</i>	Elephant Bush
<i>Portulacaria afra</i> 'Variegata'	Rainbow Bush
<i>Rebutia kupperana</i>	Scarlet Crown Cactus
<i>Rebutia minuscula</i>	Red Crown Cactus
<i>Sedum</i> spp.	Stone Crop
<i>Sedum acre</i>	Golden Carpet, Gold Moss, Stone Crop
<i>Sedum adolphi</i>	Golden Sedum
<i>Sedum dasyphyllum</i>	Golden Glow
<i>Sedum lineare</i>	Carpet Sedum
<i>Sedum morganianum</i>	Burro's or Donkey's Tail
<i>Sedum multiceps</i>	Miniature Joshua Tree
<i>Sedum pachyphyllum</i>	Jelly Beans
<i>Sedum rubrotinctum</i>	Christmas Cheer
<i>Sedum stahlii</i>	Coral Beads

Native Species*

Native species - native in this context is being defined as any plant native to somewhere in the continental United States, not just Oklahoma.

Trees

Birch, River
(*Betula nigra*)

Black Gum
(*Nyssa sylvatica*)

Buckeye, Bottlebrush
(*Aesculus parviflora*)

Buckeye, Ohio
(*Aesculus glabra*)

Buckeye, Red
(*Aesculus pavia*)

Buckeye, Texas
(*Aesculus glabra* var. *arguta*)

Buckthorn, Carolina
(*Rhamnus caroliniana*)

Cedar, California Incense
(*Calocedrus decurrens*)

Cedar, Western Red
(*Thuja plicata*)

Cucumbertree, Yellow
(*Magnolia acuminata*)

Cypress, Arizona
(*Cupressus arizonica*)

Cypress, Bald
(*Taxodium distichum*)

Cypress, Pond
(*Taxodium ascendens*)

Dogwood, Gray
(*Cornus racemosa*)

Elm, Cedar
(*Ulmus crassifolia*)

Falsecypress, Whitecedar or Atlantic
(*Chamaecyparis thyoides*)

Fringetree
(*Chionanthus virginicus*)

Hawthorn
(*Crataegus* spp.)

Hophornbeam, American
(*Ostrya virginiana*)

Hornbeam, American
(*Carpinus caroliniana*)

Kentucky Coffeetree
(*Gymnocladus dioica*)

Magnolia, Sweetbay
(*Magnolia virginiana*)

Maple, Caddo Sugar
(*Acer saccharum* 'Caddo')

Maple, Red
(*Acer rubrum*)

Oak, Blackjack
(*Quercus marilandica*)

Oak, Bur
(*Quercus macrocarpa*)

Oak, Chinkapin
(*Quercus muehlenbergii*)

Oak, Nuttall
(*Quercus nuttallii*)

Oak, Pin
(*Quercus palustris*)

Oak, Post
(*Quercus stellata*)

Oak, Red
(*Quercus rubra*)

Oak, Shingle
(*Quercus imbricaria*)

Oak, Swamp White
(*Quercus bicolor*)

Oak, White
(*Quercus alba*)

Oak, Willow
(*Quercus phellos*)

Pine, Eastern White
(*Pinus strobus*)

Pine, Limber
(*Pinus flexilis*)

Plum, Sand or Chickasaw
(*Prunus angustifolia*)

Redbud
(*Cercis* spp.)

Redcedar, Eastern
(*Juniperus virginiana*)

Serviceberry
(*Amelanchier* spp.)

Silverbell, Carolina
(*Halesia tetraptera*)

Smoketree, American
(*Cotinus obovatus*)

Soapberry, Western
(*Sapindus drummondii*)

Sourwood
(*Oxydendrum arboreum*)

Sumac, Fragrant
(*Rhus aromatica*)

Sycamore
(*Platanus occidentalis*)

Witchhazel, Common
(*Hamamelis virginiana*)
Witchhazel, Vernal
(*Hamamelis vernalis*)
Yellowwood, American
(*Cladrastis kentukea*)

Shrubs

Bayberry, Northern
(*Myrica pensylvanica*)
Beautyberry, American
(*Callicarpa americana*)
Bladdernut, American
(*Staphylea trifolia*)
Blueberry, Highbush
(*Vaccinium corymbosum*)
Butterfly Bush
(*Buddleia* spp.)
Buttonbush
(*Cephalanthus occidentalis*)
Chokeberry, Black
(*Aronia melanocarpa*)
Chokeberry, Red
(*Aronia arbutifolia*)
Clethra, Summersweet
or Sweet Pepperbush
(*Clethra alnifolia*)
Currant, Clove
(*Ribes odoratum*)
Devil's-walkingstick
(*Aralia spinosa*)
Fothergilla, Dwarf
(*Fothergilla gardenii*)
Fothergilla, Large
(*Fothergilla major*)
Holly, American
(*Ilex opaca*)
Holly, Common Winterberry
(*Ilex verticillata*)
Holly, Inkberry
(*Ilex glabra*)
Holly, Deciduous or Possumhaw
(*Ilex decidua*)
Honeysuckle, Southern Bush
(*Diervilla sessifolia*)
Hydrangea, Smooth
(*Hydrangea arborescens*)
Hydrangea, Oakleaf
(*Hydrangea quercifolia*)
Juniper
(*Juniperus* spp.)

Mahonia
(*Mahonia* spp.)
Rhododendron and Azalea
(*Rhododendron* spp. and cultivars)
Sweetshrub, Common
or Carolina Allspice
(*Calycanthus floridus*)
Sweetspire, Virginia
(*Itea virginica*)
Viburnum, American Cranberrybush
(*Viburnum trilobum*)
Viburnum, Arrowwood
(*Viburnum dentatum*)
Viburnum, Blackhaw
(*Viburnum prunifolium*)
Viburnum, Southern Blackhaw
(*Viburnum rufidulum*)
Viburnum, Nannyberry
(*Viburnum lentago*)
Yellowroot
(*Xanthorhiza simplissima*)

Vines

Ampelopsis
(*Ampelopsis* spp.)
Bittersweet
(*Celastrus* spp.)
Boston Ivy
(*Parthenocissus* spp.)
Clematis
(*Clematis* spp.)
Crossvine
(*Bignonia capreolata* 'Tangerine Beauty')
Dutchman's-pipe
(*Aristolochia marophylla*)
Grape
(*Vitis* spp.)
Passionflower Vine
(*Passiflora incarnata*)
Virginia Creeper
(*Parthenocissus* spp.)

* This list does not represent a comprehensive view of native ornamentals that could be grown in Oklahoma

Table 6.13. Diagnosing Symptoms of Common Indoor Plant Problems.

		Foliage		Growth				Flowers					Possible Causes:			
	<i>tips or margins brown</i>															
	<i>bend down and curl</i>															
	<i>yellowish green</i>	●	●													
	<i>oldest drop</i>			●												
	<i>all drop</i>	●	●													
	<i>spots</i>	●														
	<i>willt</i>	●														
	<i>weak, thin and soft</i>			●												
	<i>new leaves small</i>			●												
	<i>none develop</i>			●												
	<i>plant died</i>					●										
	<i>fail to develop--bud drop</i>	●	●	●	●	●	●	●	●	●	●	●	●	●	●	●
	<i>color is less intense</i>															
	<i>decline too fast</i>															
	<i>become smaller</i>															
	<i>no blooms</i>															

EXCESS LIGHT: i.e. exposure to direct sun can be too intense for many plants.

INSUFFICIENT LIGHT: impairs photosynthesis and flowering.

DAYLENGTH: if too short reduces growth, flowering and life-expectancy.

HIGH TEMPERATURE: especially at night reduces growth and vigor, also detrimental for flowering.

LOW TEMPERATURE: continued exposure is adverse to plant growth.

LACK OF WATER: limiting factor for growth and survival.

OVERWATERING OR POOR DRAINAGE: reduces soil aeration--roots die, water and nutrients are not absorbed.

TOO MUCH FERTILIZER: accumulation of soluble salts injures plant roots, reduces water uptake.

LACK OF FERTILIZER: causes a deficiency of nutrients required for plant growth.

COMPACTED SOIL: reduces root functions and activity.

GROWING CONTAINER: too small or too large in relation to plant size.

LOW HUMIDITY: air too dry to maintain healthy growth and flowering.

Chapter 7: TURFGRASS

Learning Objectives:

After completing this section, Master Gardener trainees will be able to:

- Have a fundamental understanding of the unique growth and seasonal characteristics of both warm- and cool-season turfgrass plants.
- Have a working knowledge of the characteristics, requirements and tolerances of the desirable turfgrass species used in Oklahoma lawns.
- Understand the natural conditions and cultural care practices that influence the growth and development of a lawn environment.
- Understand the principles and components of successful lawn establishment and renovation.
- Identify, comprehend and set control strategies for key pests common to Oklahoma lawns.

Chapter 7: Turfgrass317

Introduction	317
Lawn Benefits	318
Successful lawn management	318
Primary and secondary practices used in lawn care	318
Turfgrass Selection.....	318
Sourcing turfgrass species and cultivars....	218
Turfgrass selection and site assessment/client assessment.....	318
Grass Types	319
Bermuda grass.....	319
Buffalograss.....	321
St. Augustinegrass	321
Zoysiagrass	321
Turfgrasses for Shaded or Irrigated Sites	322
Proper Turfgrass Establishment Practices	323
Fertilization	323
Irrigation to supplement natural rainfall.....	325
Mowing	327
Tatch	327
Aerification.....	328
Weed Control.....	328
Herbicides and terminology	328
Weed identification and lawn grass identification	329
Insect Control	31
Disease Control	331

Preface

This chapter is intended to be used in harmony with the turfgrass training presentation. Additionally, this manual segment is not intended to be a comprehensive end-all source on turfgrass management. It should be used in conjunction with each of the fact sheets and current reports that are referenced herein as well as with various resources referenced on the internet.

Introduction

The home lawn is an integral part of the total landscape. The landscape is the merger of the lawn, trees, shrubs, ornaments, berms, ponds, paths and various hard-scape elements. The lawn is the area of the landscape that is comprised of living plant material with the specific features of being relatively low growing; tolerant of regular foot traffic, mowing or animal grazing; and provides soil stabilization and beautification. The lawn can be comprised of any number of different types of plants with these characteristics, including grasses, sedges, rushes and various broad-leaf plants. Most often, the lawn is comprised of grasses; in particular, a special sub-group of grasses called turfgrasses. Turfgrasses and their culturing

will be discussed throughout the remainder of this chapter.

Lawn benefits

The lawn provides a setting for trees and ornamentals, as well as the home, and it provides a setting for outdoor family activities. In addition to these features, lawns provide many benefits to people, including but not limited to:

- Resistance against soil erosion caused by wind and water.
- Reduction in noise, dust and glare.
- Reduction in surface water runoff and increased water infiltration into the soil.
- Providing for a safer surface for recreation and a more forgiving surface for player falls than hard-scape elements such as asphalt, concrete, gravel, bark, wood chips, mulch or artificial turf.
- Increased property value in most circumstances.
- Beautification and presentation of the home.

Successful lawn management

Successful home-lawn management is based in sound decision-making and, when properly implemented, the program ensures the functional lawn remains in place through time. The overall process for development of a successful lawn and lawncare program includes:

- Proper assessment of the conditions and needs of the site and the client.
- Selection of turfgrass species and cultivars that are 1) adapted to the specific site conditions and 2) meet the majority, if not all needs expected by the client. Some conditions of the site may require minor modification to meet these goals.
- Proper installation or establishment of the lawn plants or turfgrasses.
- Proper long-term management of the lawn plants or turfgrass to meet site and client needs.

Primary and secondary practices used in lawncare

Once properly installed, the overall process of long-term lawn or turfgrass management includes the following steps:

- Primary management practices:
 - Mowing
 - Fertilization
 - Irrigation
- Secondary management practices
 - Aeration
 - Dethatching
 - Traffic management
 - Pest management
 - ▶ Insect pest management
 - ▶ Animal pest management
 - ▶ Disease management
 - ▶ Weed management

Turfgrass Selection

Sourcing turfgrass species and cultivars

Once the site assessment, client assessment and grass selection decision-making has been completed, locate available sources of the desired turfgrass species and cultivars. Useful resources include a web search, as well as OSU Current Reports (CR). Those resources include CR-6605 *Oklahoma Turfgrass Sod Source Directory* and CR-6609 *Buffalograss Sod Source Directory*.

Turfgrass selection and site assessment/client assessment

Turfgrasses are a subset of grasses whose shoot and root systems form a more or less continuous mat of intermingled plants. Turfgrasses are those grasses having a relatively low, spreading growth habit and tolerate regular mowing or grazing, as well as a moderate amount of foot traffic during their active period of growth.

The geographic location of Oklahoma permits turfgrass species popular in the northern, southern, eastern and western environments of the U.S. to be grown somewhere in the state. However, high temperatures and limited rainfall during the summer limit the success of the cool-season turfgrass species to the light to moderately shaded areas and full-sun sites with irrigation systems. Cool-season grasses grow best in the cooler portion of the year, such as the spring and fall and tolerate winter well. Cool-season grasses are often challenged by the heat and decline in health during mid- to late June through August. Cool-season grasses gener-

ally have high water use rates and limited ability to tolerate drought.

Warm-season grasses grow well in the summer heat, provided suitable rainfall occurs or supplemental irrigation is being used, but they have slower growth during the cool periods of late fall and early to mid-spring. Warm-season grasses suffer top growth kill from freezing conditions and remain dormant in the winter. Overall, warm-season grasses have a lower water use rate and better drought resistance than cool-season grasses. However, there can be specific exceptions to these very generalized assumptions.

Successful turfgrass management begins with the selection of a turfgrass species adapted to the wide fluctuations in temperature and moisture found in any single area within the state. Within a site there may be environmental limitations caused by shade (reduced availability of sunlight), no supplemental water beyond natural rainfall or poor soil conditions.

Proper selection of a turfgrass for a lawn site not only involves the selection of a well-adapted turfgrass, but also selecting one that fits the needs of the client. For instance, provided the client can meet the labor and monetary costs of a lawn maintenance program, does the client want a showplace lawn (with management inputs to match), a neighborhood sports field, an average lawn, a low-input lawn that preserves the natural character and reflects the native plant materials indicative of the area or simply “something alive and green some of the time” and able to simply cover and protect the soil from erosion? Generally it is not feasible to have it all, especially on a small budget. Sometimes a client’s management skills or lack of financial resources, as well as lack of disposable management time in caring for the lawn may dictate a lower input and/or lower visual and lower functionally impactful lawn be put in place. Thus, all of the features wished for in a lawn may not be possible, but there are well-adapted turfgrasses that can meet most desires and are affordable to manage.

Shaded areas can be one of the most challenging sites to manage due to the reduced sunlight, which is used by the plant in manufacturing food (carbohydrates). Restricted air movement caused by heavy tree cover and tree root competition for moisture and nutrients can lead to conditions more conducive to disease, especially on cool-season

grasses. Development of realistic expectations in terms of lawn performance within the budgetary resources of an individual is not only a requirement for the homeowner or client but also a discernment skill that requires culturing and practice.

Grass Types

Taxonomical botanists are those scientists and technologists who, among other areas of responsibility, study and work in the area of classification of the identity of plants. The family of grasses contain many genera or sub-groups within the family of grasses. Within each genus is one or more species, a sub-group within the genus or a sub-sub group within the grass family. Within each grass species are varieties or a sub-group within the species. Specific grasses are bred, collected, selected and preserved due to some valuable features these types provide. It is these special cultivated varieties for which the term cultivar is applied. Not being a stickler for names, the U.S. trade industry regularly interchanges the terms cultivar and variety, so be prepared to see either term used by gardeners, scientists and sales personnel. ‘Kentucky 31’ is an example of a cultivar of the species tall fescue grass. ‘U-3’ is an example of a cultivar of the species common Bermuda grass. There are thousands of cultivars of turfgrass available around the world, but only few dozen cultivars will be discussed here.

Bermuda grass (Cynodon species)

The Bermuda grasses are a group or genus of grasses widely distributed across the world. However, only two species of Bermuda grass are regularly used in Oklahoma and are the group of turf-type common Bermuda grasses (*Cynodon dactylon* variety *dactylon*) and the group of interspecific hybrids (*Cynodon dactylon* X *Cynodon transvaalensis*) created by natural or human-made crosses between the common Bermuda grasses and the African Bermuda grasses (*Cynodon transvaalensis*). Interspecific means crosses between two different species, whereas intraspecific means crosses within a species.

The common Bermuda grass species is very dynamic, widely adaptable and is now used for turfgrass in the warmer areas of six continents. The



Figure 7.1. Bermuda grass.

species is comprised of millions of different genotypes or specifically identified individuals. It is important to mention that even the most scholarly and experienced of turfgrass scientists can rarely, truly identify a Bermuda grass genotype merely by looking at it. While turf management practitioners and scientists can often identify a turfgrass to its scientific genus level or even to the species level (an even more specific level of ID), identification to the cultivar or variety level generally is not feasible. Often, simple deductive logic is being used in trying to place a turfgrass as to its variety or cultivar level within the species and the person is not actually truly able to identify the cultivar by mere physical examination. DNA fingerprinting methods are used to identify specific strains of grasses versus other species or strains, but these methods largely remain lab-based and their financial cost as well as time-consuming nature prevent their use in the casual identification of samples sent to any of OSU's diagnostic labs or Extension offices.

African Bermuda grass receives some use as a turfgrass species in Africa, but in the U.S. the hybrids created between African and common Bermuda grasses are more often used. African Bermuda grasses have not proven to be well-adapted for use in Oklahoma, therefore not regularly available in the trade. In general, use is discouraged by all but the most avid of "grass tinkerers."

In general, Bermuda grasses are warm-season turfgrasses that spread rapidly by above-ground (stolons) and below-ground (rhizomes) stems. Bermuda grasses were once native (originally limited to) to Africa, Asia, Australia and southern Europe, but have been introduced into North

America and South America. Although Bermuda grasses are not native to Oklahoma, they have escaped cultivation and have naturalized throughout Oklahoma and have become quite well adapted to the wild areas of Oklahoma. People have different definitions for the word "common" with respect to Bermuda grass: 1. 'common Bermuda grass' meaning the specific species *Cynodon dactylon*, and 2. the spoken phrase "The Bermuda grass that I have in my lawn is just some old common type," meaning that the grass is not a specifically known, improved type. If important, be specific with the cultivar name.

Bermuda grass is often considered the best-adapted turfgrass for full-sun areas in Oklahoma due to its excellent heat and drought tolerance during the summer and its sufficient winter hardiness. Bermuda grasses can vary considerably in appearance. Some members of the common Bermuda grass species are more forage-like in appearance, having a low number of aerial shoots per area and wide leaf blades. Such types give the appearance of a coarse, open (non-dense) lawn rather than a thick lawn, comprised of many aerial shoots per area and narrower leaf blades. A lawn having a very high shoot density, where the individual leaves are narrow, gives the appearance of fine texture. Most people tend to like a fine-textured lawn rather than a coarse-textured lawn, but there can be different preferences amongst individuals. The appearance preference can influence which cultivars and species are chosen, provided they can be found with the necessary adaptation to the site conditions present.

It has often been said that turfgrass cultivars having a fine texture (relative measure of leaf-blade width) and a high turf density (number of leaves or stems per unit area) are best suited for areas such as closely mowed athletic fields and golf courses. However, this is based on the assumption the client did not wish to perform the more intensive management practice of frequent and lower mowing. The client can use fine textured and dense turfgrasses if they are willing to either conduct frequent and close mowing or hire this management practice on a regular basis.

Likewise, it has been said that the coarser-textured, lower-density, common cultivars of Bermuda grass (and turfgrasses in general) are better suited for home lawns because they require lower amounts of maintenance (fertilizing, mowing and

dethatching). This assumption again is based on assuming that the consumer does not or cannot manage the lawn or they can not pay for regular mowing or more intensive management practices. Remember it is important to conduct a thorough client assessment to determine the wishes of the lawn owner and help them understand what management practices must occur in association with achieving certain utilitarian and visual outcomes from the lawn. There is not a correct one size fits all approach to placing a grass species and cultivar with a lawn owner, the client assessment and selection process is an individual process.

Buffalograss (*Bouteloua dactyloides*)

Buffalograss, or more specifically American buffalograss, formerly had the botanical name *Buchloe dactyloides*, but has been reclassified to the genus and species name *Bouteloua dactyloides*. Buffalograss is a warm-season, sod-forming grass native to short, mixed and tall-grass prairies in Oklahoma. It spreads by aboveground runners (stolons) and by seed (in certain cases). It has a fine texture and a silvery, grayish-green color. Many cultivars of buffalograss have excellent tolerance to the heat, drought and cold conditions found in Oklahoma. Buffalograss is best suited to full-sun sites in areas of Oklahoma receiving 12 to 25 inches of rainfall per year, but it can be regularly found in the 35-inch rainfall belt.

Buffalograss grows best on heavy-textured soils, but can occasionally be found on sandy sites. It has great tolerance of alkaline soils, if they are not high in sodium. While some types of buffalograss can tolerate salt, it is not as tolerant of high salinity soils as are many Bermuda grasses, zoy-



Figure 7.2. Buffalograss.

siagrasses and especially inland saltgrasses. Buffalograss often is a good choice for non-irrigated lawns on heavy textured soils in full sun, especially in western Oklahoma.

Cultivars of buffalograss in the commercial trade should be thought of as those produced purely by clonally propagated means or those intended to be propagated by seed, but may be seeded to a sod production field to produce sod. Buffalograsses are unique because they are principally dioecious, but occasionally monoecious. This means they principally have separate plants that produce exclusively male flowers or exclusively female flowers, but occasionally, a single buffalograss plant will produce both male and female flowers on the same clonal plant. This characteristic has implications concerning the selection and purchase of buffalograss cultivars because some cultivars such as 'Prestige,' 'Legacy,' '609' and 'Prairie' are exclusively female clonally or vegetatively propagated lines. They are not propagated by seed, but rather by plugs or by sod. Seeded lines such as 'Texoka,' 'Comanche,' 'Topgun,' 'Cody,' 'Bowie' and 'Sundancer' are cultivars that produce a mixed population of male and female flower-bearing plants. These cultivars are intended to be seeded, but with the proper circumstances, can be seeded to a sod production field. If cultured properly, sod of the mixed male/female population can be harvested, transported and installed in a lawn. Mixed male/female cultivars produce numerous male flowers above the grass leaf canopy, which some people may find distracting from the general appearance of the turf. Thus, it is important to assess the client's wishes rather than automatically assuming they will want a clonal female type or a mixed male/female population.

St. Augustinegrass (*Stenotaphrum secundatum*)

St. Augustinegrass is a medium- to coarse-textured, warm-season turfgrass that spreads by stolons. It is suited to southern Texas, but can sometimes be grown in the extreme southern regions of Oklahoma on sheltered sites. Shaded lawns of St. Augustinegrass can be regularly found in the communities of Ardmore, Durant, Madill and Hugo. A few lawns of St. Augustinegrass can be found in McAlester and Poteau, but not reliably farther north in Oklahoma than these sites.



Figure 7.3. St. Augustinegrass.

St. Augustinegrass produces a quality lawn on full-sun to lightly-shaded sites in the far southeastern part of Oklahoma. However, it requires more frequent watering and better soil conditions than Bermuda grass. Selections of Texas common St. Augustinegrass may appear to have greater winter hardiness than many of the other commercially available cultivars, but Raleigh has been a relatively reliable cultivar to use where St. Augustinegrass is well adapted.

Zoysiagrass (*Zoysia spp.*)

The Zoysiagrass genus is comprised of several species native to Asia and useful as turfgrass species in the U.S. The most commonly used zoysiagrass species are the Japanese lawn grass species (*Zoysia japonica*) and the matrella zoysiagrass (*Zoysia matrella*), but several other species and interspecific hybrids are also used in lawns across the world.

Zoysiagrass is a fine- to medium-textured, warm-season turfgrass that spreads by stolons



Figure 7.4. Zoysiagrass.

and rhizomes. Many types, but not all, are winter hardy in Oklahoma. Nearly all zoysiagrasses have some ability to grow under light shade. This is one of its desirable features, since most zoysiagrasses have better shade tolerance than most Bermuda grasses. However, this does not mean zoysiagrass is tolerant enough to work in all shaded conditions.

Zoysiagrasses are generally slow to establish, especially the old cultivar Meyer Z-52. Newer cultivars of zoysiagrass such as 'El Toro,' while slower to spread than most Bermuda grasses, can spread three to five times faster than Meyer zoysiagrass. In general, the slower establishment rate of zoysiagrasses, coupled with their higher water use rate, susceptibility to mites and large patch fungal disease are the greatest liabilities. The improved shade tolerance, less frequent mowing requirement and much greater resistance to weed invasion (when healthy) are the assets of a zoysiagrass lawn.

Zoysiagrass requires more frequent watering to prevent wilting than Bermuda grass, but has lower annual fertilizer requirements. Zoysiagrass, like the fine-textured Bermuda grasses, should only be utilized for lawns when a top-quality turf is desired and a somewhat higher maintenance required turf is tolerable.

Meyer zoysiagrass (Z-52), a variety not stated (VNS) matrella zoysiagrass, and El-Toro zoysiagrass are the only cultivars commercially available in large quantities in Oklahoma. For those living in southern Oklahoma, there are a number of producers of zoysiagrass sod in Texas north of the Dallas-Ft. Worth metroplex. Many zoysiagrasses can be used as lawn types in Oklahoma, but are not currently produced or available as sod in Oklahoma. Many cultivars that have good adaptation to Oklahoma can be found at the National Turfgrass Evaluation website at www.ntep.org. This site reviews past zoysiagrass cultivar evaluation trials conducted at Stillwater.

Turfgrasses for Shaded or Irrigated Sites

Cool-season grasses might provide a green cover the entire year if properly watered and fertilized. Occasionally, cool-season turfgrass species are the best selection for lawns. This may be due to the client wanting a naturally green lawn for the greatest number of months during the year,

or because many warm-season turfgrasses cannot tolerate shaded sites (with the exception of St. Augustinegrass). So, a cool-season turfgrass such as tall fescue (*Festuca arundinacea*), Kentucky bluegrass (*Poa pratensis*) or perennial ryegrass (*Lolium perenne*) might be seeded (ideally in the fall) or sodded (any time except June to early September). Even with improved shade tolerance, a cool-season grass may not be able to survive in shaded sites. For specific tips on how to better manage turfgrass in shade, see the Extension Fact Sheet HLA-6608 *Managing Turfgrasses in Shade*. Also consult Fact Sheet HLA-6418 *Selecting a Lawn Grass in Oklahoma* for more details on picking cool-season turfgrasses for the lawn.

Cool-season turfgrasses, such as tall fescue and Kentucky bluegrass also can be successfully grown in full sun, but require more frequent watering during the summer to prevent wilting, thinning and a loss of turf density. Other than in the high rainfall areas of far northeastern Oklahoma, cool-season turfgrasses may be utilized in full sun only when a convenient means of irrigation is available. Even so, diseases such as Pythium blight and Rhizoctonia blight, as well as large brown patch (all three deadly diseases of tall fescue and ryegrass) may spell disaster for cool-season turfgrasses. It does not matter if it is in full-sun or shade or whether irrigated or not in years with high natural rainfall, high air temperatures and high relative humidity, these diseases are problems.

Perennial ryegrass and annual ryegrass, sometimes called Italian ryegrass (*Lolium multiflorum*), can also be utilized for overseeding into dormant warm-season turfgrasses or for soil stabilization during the fall and spring when a turf cover is rap-



Figure 7.5. Shaded grass area.



Figure 7.6. Irrigation of grass.

idly needed. Perennial ryegrass (*Lolium perenne*) is commonly seeded into an established Bermuda grass turf when a fine-textured, green turf cover is desired from late fall (November) through mid-spring. Annual ryegrass is less expensive and is also successfully used for the same purpose, although it provides an inferior quality in winter turf compared to perennial ryegrass. Sometimes, perennial ryegrasses are much more tolerant to summer heat and lives into the summer months. Shading of the Bermuda grass causes failure or severe injury due to poor transition. “Transition” is the process of a winter-overseeded cool-season grass intentionally placed in a warm-season grass base lawn is performing well in winter and spring and the cool-season grass gradually dies out (as hoped) in mid- to late spring. Poor transition is when an overseeded cool-season grass survives too long into the late spring or summer, causing excess shading and stand loss of the warm-season turfgrass base.

Advances in turfgrass breeding have led to special annual, intermediate and perennial ryegrass cultivars that have been bred and selected to have features of special value for the winter-overseeding market. These grasses have improved color, texture, density, growth habit and improved summer transition as compared to those annual ryegrasses used merely as forage/soil stabilizer types. These special overseeding types also are considerably more expensive than general purpose or forage/soil stabilizer types.

Annual ryegrass is also commonly used for temporary soil stabilization on construction sites that are completed during the fall and winter, when

conditions are unfavorable for establishment of warm-season turfgrasses. Use of annual ryegrass for soil stabilization is considered a specialty use and the Master Gardener should check with their county Extension educator or Master Gardener Trainer for additional details concerning this specialty topic area.

While only 11 turfgrass species have been briefly covered in this manual section, there are more than 30 turfgrass species that could possibly be used at various locations in Oklahoma. Even so, these 11 species listed are adequate for the Master Gardener to develop an understanding of the selection process so they can suggest adapted types for lawns in various areas of the state.

The best adapted turfgrass will perform only as well as the lawn-management practices it receives. Correct and timely fertilization, watering, mowing and pest control (weeds, insects and diseases) will ensure turfgrass obtains its potential for quality and adaptation.

Proper Turfgrass Establishment Procedures

Turfgrass establishment is covered in depth in Extension Fact Sheet HLA-6419 *Establishing a lawn in Oklahoma*. The Master Gardener in training should become thoroughly acquainted with the site preparation techniques and various establishment procedures of seeding, sodding, sprigging and plugging to be able to effectively understand and communicate this essential aspect of turfgrass management.

Fertilization

Fertilization is important because it improves turfgrass density, color and recuperative potential. Fertilization is important in terms of its roll in turfgrass establishment (see HLA-6419) and in long-term turfgrass maintenance (See HLA-6420). A healthy, properly fertilized, dense turfgrass better resists, but is not immune to, weed invasion and is able to better tolerate heat, cold, drought and wear.

Fertilizer elements

Turfgrass plants require approximately 16 essential elements for normal growth and development.

Each of these mineral elements is required for plant growth, but concern of application of each differs because plants utilize them in variable amounts (thus the terms macro, secondary and micronutrients). On most normal, native topsoils that consist of clays, clay loams, loams, silts and silty clay loams, the secondary and micronutrient levels present generally are not limiting to turfgrass lawn growth. Extremely sandy soils may require attention to all 13 mineral elements, due to their low organic matter content and high water infiltration rate and inability to retain nutrients and water.

In this turfgrass chapter only macronutrients will be discussed, but remember that with certain conditions, a knowledge and understanding of the roll and supplementation of the remaining essential nutrients might be required.

Nitrogen, phosphorus and potassium might be needed during turfgrass establishment, during the beginning of each growing season and during periods when extra-hardy tissue development is needed. Applications of N-containing fertilizers are particularly important in lawn management because 1) N is the nutrient required in greatest amounts, 2) the level of N within turfgrasses is correlated to plant quality (color and density) and vigor and 3) plant-available N is often minimal and limiting in most topsoils of Oklahoma.

In addition to N, P and K also are required in relatively large quantities for healthy plant growth. Fertilization for turfgrass need not be in large quantity nor as frequent. Fertilizations should always be based on a soil test analysis and recommendation. Deficiencies in nutrients should be corrected for optimal turfgrass growth unless the intent is to operate an extremely low input and low "visual output" lawn. Adding P and K above levels determined by a soil test is wasteful because it can cause negative environmental impacts. There is no evidence turfgrass quality is enhanced at super-optimal soil test levels.

The P test level Extension generally considers optimal for most turfgrasses is a value of 65, when using the Mehlich III test. The Mehlich III test is the testing procedure used for P and K by the OSU Soil, Water & Forage Lab (OSU SWFL). Please note that other labs might use other testing procedures, so different optimum test index levels may be noted. Use the same lab for all testing for continuity. The K test level generally considered optimal by Extension is a value of 250 when using OSU SWFL.

Table 7.1. Fertilization program for bermudagrass lawns.¹

Date	Elements	Pounds of N per 1000 ft. ²	Fertilizer ² (N-P ₂ O ₅ -K ₂ O)	Pounds fertilizer per 1,000 ft. ²	Pounds fertilizer per acre
May 1	N+P+K	1.0	{ 20-5-10 15-5-10 10-5-5 10-20-10	5.0	218
				6.7	292
				10.0	436
				10.0	436
June 1	N	1.0	{ ammonium nitrate (34-0-0) ammonium sulfate (20.5-0-0) urea (46-0-0) slow release N sources ³ Milorganite (6-4-0) sulfur-coated urea (32-0-0)	3.0	131
				4.9	213
				2.2	96
				16.7	727
				3.1	135
July 1	N	1.0		—same as June 1—	
Aug 1	N	1.0		—same as June 1—	
Sept 1	N+P+K	1.0		—same as May 1—	
November - April: Based on a soil test, correct phosphorus and potassium deficiencies and extremely low or high soil pH.					

¹ A moderate fertilization program for Arizona common, U-3, and Guymon bermudagrass and a maximum fertilization program for zoysiagrass and buffalograss would include fertilizer applications on May 1, July 1, and September 1.

² Always immediately water-in water-soluble, quickly available fertilizers.

³ Apply slow-release fertilizers at a higher rate (2 to 3 pounds N per 1000 ft.² per application) but use fewer fertilizer applications.

Soil testing, the “right” first step

The availability of mineral elements in the soil is influenced by soil pH. Soil pH is a measure of the concentration of hydrogen ion in the soil or a measure of soil acidity or alkalinity. The soil pH scale goes from 1 to 14, and a pH of 7 is neutral. Below 7 is acidic, and above is alkaline. The 13 essential mineral elements are each most available at a certain pH. Between pH 6.0 and 6.5, all essential soil elements present in the soil are more readily available for optimal turfgrass growth. A soil test is needed to determine soil pH and whether crushed and finely ground limestone (to raise pH) or an acidifying material such as elemental sulfur (to lower pH) is required.

The proper steps for determining N, P, K, the level of other elements and pH through a soil test are listed below.

- Follow a random pattern when sampling. Take about 10 to 15 cores from the established turfgrass area, totaling about one pint.
- All cores should be taken at a consistent depth (3 to 4 inches). Discard thatch, leaves and stems, but keep any soil.
- Place all samples in a container and mix thoroughly.
- Remove a one-pint soil sample and take it to the local county Extension office for soil-test

analysis. The routine or basic soil analysis will include N, P, K and pH. The OSU soil laboratory or the county educator will write fertilizer recommendations, based on the results.

For more information on soil testing, see L-249, “Soil Testing, the Right First Step Towards Proper Care of Your Lawn and Garden,” from the local county Extension office or from the website osufacts.okstate.edu. For a more thorough coverage of soil pH, see Fact Sheet PSS-2229 *Soil pH and Buffer Index*.

Fertilizer programs

Table 7.1 shows recommendations for lawn fertilization. The fertilization program is designed for maximum turfgrass quality and a relatively high maintenance input for a Bermuda grass lawn. In this example, it is assumed that P, K and pH levels are satisfactory as determined by a soil test. Have a new soil test about once every three years. In the fertilization program example in Table 7.1 of HLA-6420, a total of 5 pounds of N are applied over 1,000 square foot area in one growing season. This amount is split into five equal but separate applications. Applications of a complete fertilizer in the spring to enhance root regeneration and one in the fall to enhance winter hardiness is a part of this

Table 2. Fertilization program for tall fescue, Kentucky bluegrass and perennial ryegrass lawns.

Date	Elements	Pounds of N per 1000 ft. ²	Fertilizer ¹ (N-P ₂ O ₅ -K ₂ O)	Pounds fertilizer per 1000 ft. ²	Pounds fertilizer per acre
Oct 1	N+P+K	1-1.5	20-5-10	5.0 - 7.5	218-327
			15-5-10	6.7 - 10.0	292-436
			10-5-5	10.0 - 15.0	436-653
			10-20-10	10.0 - 15.0	436-653
Dec 1	N	1-1.5	ammonium nitrate (33-0-0)	3.0 - 4.5	131-196
			ammonium sulfate (20.5-0-0)	4.9 - 7.3	213-318
			urea (45-0-0)	2.2 - 3.3	96-145
March 1	N	0.5-1	ammonium nitrate	1.5 - 3.0	65-131
			ammonium sulfate	2.5 - 4.9	109-213
			urea	1.1 - 2.2	48-96
May 12	N+P+K	0.5-1	20-5-10	2.5 - 5.0	109-218
			15-5-10	3.3 - 6.7	144-292
			10-5-5	5.0 - 10.0	218-436
			10-20-10	5.0 - 10.0	218-436

¹ Always immediately water-in water soluble, quickly available fertilizers.
² If available, always use a slow-release fertilizer in the spring and early summer.

example program. Less fertilizer can be applied to reduce the total amount of N, if it is deemed appropriate. Such conditions might be where the site has naturally high levels of organic matter in the soil, an older lawn that is naturally more fertile or an environmentally sensitive site. Good Bermuda grass quality and lower amounts of mowing, dethatching and watering can be achieved by reducing the number of N fertilizer applications during summer. Total yearly N applications of 3 pounds per 1,000 square feet is acceptable. This is particularly true for the common-type Bermuda grass cultivars, buffalograss and zoysiagrass.

Fertilizations made prior to spring green-up are not as effective as those made two weeks following green-up. Fertilizer applications made after September 1 in northern counties might stimulate lush fall growth. This might hinder Bermuda grass winterization and possibly lead to more severe Spring Deadspot Disease (SDS). Applications of water soluble, quickly available fertilizer of more than 1 pound N per 1,000 square feet are not likely to enhance turf quality. Water-soluble or quickly available fertilizer materials should always be immediately watered into the soil following application with about 0.25 inches of water to avoid burning turf foliage. Slow-release or controlled release fertilizers are those whose N component is

not immediately available for plant uptake, but in the presence of continued warm, moist soil will become available to the plant gradually over several weeks to a few months. Examples of such fertilizers can include Milorganite, reactive layer coated urea and sulfur-coated urea. Such fertilizers are of value when fertilizing warm-season grasses in summer, but may not always be a good fit for use on cool-season turfgrasses that have very little N need in summer in Oklahoma. Slowly available N source fertilizers can be applied less frequently and at higher rates of N per 1,000 square feet per application to warm-season grasses. A possible program would include a spring fertilization with a water soluble, quickly available complete fertilizer, a June fertilization with a slow-release fertilizer (2 to 3 pounds N per 1,000 square feet) and an August fertilization with a slow-release fertilizer (2 to 3 pounds N per 1000 square feet). The August fertilization can also serve as the fall fertilization for a warm-season grass if enough N was put down in that application.

The cool-season turfgrasses – tall fescue, Kentucky bluegrass and perennial ryegrass – do not need as much fertilizer as Bermuda grass, when considering a maximum care and maximum visual impact lawn management program. For instance, a maximum N fertilization program for cool-season

grasses would never exceed a total of 4 pounds of N per 1,000 square feet per year, applied in four separate applications. Cool-season grasses need most of their annual fertilizer in the fall, with small amounts in the spring, and very little, if any, during the summer. A fertilization program for tall fescue, Kentucky bluegrass and perennial ryegrass is outlined in Table 7.2.

Fertilizers types

For examples of specific fertilizers to be used in lawn care programs, refer to Fact Sheet HLA-6420 *Lawn Management in Oklahoma*. The local county Extension educator, the Master Gardener Trainer or the OSU SWFL may provide a number of different types of fertilizers that can be used in lawn care. An important training exercise is to take the printed resource with the fertilizer recommendation to a local coop, garden center or other location where various fertilizers are available to compare. You will most likely be asked by your consumer clients where they can purchase certain specific fertilizers locally. As a Master Gardener living locally, you are in the best position to know what is available.

Irrigation to supplement natural rainfall

Watering is one of the most often misunderstood aspects of turfgrass culture. Please study Fact Sheet HLA-6420 concerning this key management practice. For those having in-ground irrigation systems, proper operation and understanding of these systems is essential. Therefore, it is highly beneficial to read the Fact Sheets HLA-6445 *Smart Irrigation Technology: Controllers and Sensors* as well as HLA-6610 *Simple Irrigation Audits for Home Lawns*. Often, watering turf areas is too frequent or in some cases, too light. Frequent, shallow watering may encourage shallow rooting and weed seed germination.

Ideally, turf should not be irrigated on a regular schedule, but by need. An irrigation program cannot be developed to fit every location due to 1) dissimilar water-holding capacities of different soil types found in Oklahoma, 2) weekly fluctuations in temperature, humidity, wind and precipitation and 3) the influence of management practices, such as mowing and fertilization on turfgrass water consumption. Sandy, coarse-textured soils absorb wa-

ter faster, but retain less water than fine-textured soils like loams and clays. Thus, it takes less water to moisten sandy soil to a 6-inch depth than to moisten a clay soil to the same depth. This means more frequent applications of less water are required for turfgrasses growing on sandy soils. Lush, actively growing turfgrasses utilize more water than turfgrasses maintained on the "lean side."

The ideal time to water is when turfgrasses show the first visual symptoms of water need or wilt, characterized by "foot printing" and a blue-gray appearance. When turfgrasses experience moisture stress, their leaves begin to roll or fold and wilt. Thus, the leaves are slower to bounce back when stepped on. Enough water should be applied in one application to wet the soil to a 6-inch depth. This can be checked by probing the soil. After a few times, a feel for the amount of time and water required for deep watering is obtained. If the area begins to puddle and run-off is occurring, stop irrigating and allow the water to soak into the soil. It may be necessary to repeat this cycle several times before proper irrigation is complete. Irrigating only when turfgrasses show the first visual symptoms of water need, then watering deep will encourage deep rooting. The ideal time to irrigate is early morning, while dew is still present and wind speed is generally low. The potential of sprinkler pattern distortion and evaporation is low, as well as the likelihood of increasing the length of time that the canopy remains wet. Generally, try to keep the turfgrass canopy leaves as dry as possible, while keeping the soil moist. Keeping the canopy dry helps to reduce, but will not eliminate, the potential for disease occurrence. This is especially true with cool-season turfgrasses.

Mowing

Table 7.3 presents turfgrass species commonly grown in Oklahoma and their seasonal cutting height. With just a few exceptions, interspecific hybrid Bermuda grasses should be mowed at lower heights than the cultivars that are members of the common Bermuda grass species. The warm-season turfgrasses are cut higher in the fall to provide insulation for low temperatures. When they are growing during the summer, they are cut lower to promote lateral spread and a tight turf. Cutting turfgrasses below their recommended height will discourage deep rooting. Cutting too low may cause the turf to thin, because it is less able to withstand heavy traffic

Table 3. Mowing height of commonly grown turfgrasses in Oklahoma.

Turfgrass	May-August	September-April
	— inches —	
Warm-Season		
Bermudagrass	0.5-0.75	1.0-1.25
Midiron		
Midfield		
Midlawn		
Tifway		
Tifway II		
Tifgreen		
Sunturf		
Arizona common	1.0-2.5	1.5-3.0
Cheyenne		
Jackpot		
Mirage		
Guymon		
U-3		
Sundevil		
Yuma		
Buffalograss	1.5-3.0	2.0-3.0
St. Augustinegrass	2.5	3.0
Zoysiagrass	0.5-0.75	1.0-1.25
Cool-Season		
Kentucky bluegrass	2.5	2.5
Perennial ryegrass	2.5	2.5
Tall fescue	3.0	2.5

and environmental stresses, such as low soil moisture and extreme temperatures. Cutting Bermuda grass above its recommended height may produce a stemmy turf, characterized by leaves being produced near the end of upright stems. This kind of turf is prone to scalping. Turfgrasses grown under shady conditions should always be maintained at a slightly higher cut to increase leaf area to compensate for lower light levels.

Ideally, turfgrasses should be mowed on a schedule based on the amount of plant growth between mowings. This will depend on the level of soil moisture, nutrients and temperature and the amount of sunlight. Since these conditions fluctuate from week to week, plant growth also fluctuates. Therefore, the ideal time to cut turfgrasses is when no more than about a third of the leaf area is removed at any one mowing. This would mean mowing U-3 Bermuda grass at 1 inch each time it reaches 1.5 inches; or mowing a lawn with a reel-type mower at 0.5 inches when it reached 0.75

inches in height, so as not to remove more than 1/3 the top growth in any single mowing event.

It is preferable not to bag grass clippings, since collecting clippings removes valuable nutrients from the lawn. Grass clippings also take up valuable space in the landfill and bagging clippings takes more time than mowing with a mulching mower. For more information about leaving grass clippings, pick up a copy of Leaflet 253, *The Don't Bag It Lawn Care Program*, at the local county Extension office.

Regardless of the type of mower used, it is essential that mowing equipment be kept sharp and in good operating condition. Dull, improperly adjusted equipment bruises leaf tips, reduces growth and causes a dull appearance over the turf area due to frayed leaf blades.

Other mowing practices should include varying the mowing pattern throughout the growing season to distribute wear, reduce soil compaction and improve turf appearance. Make turns on sidewalks and drives or make wide turns to avoid tearing the turf. Lastly, avoid mowing wet grass. It is harder to obtain a quality cut, clippings form clumps on the mower and turf and disease organisms are more likely to be spread.

Thatch

Bermuda grass and zoysiagrass are particularly prone to developing an excessive (greater than 0.5 inch) layer of thatch. Thatch is undercomposed roots and stems. Excessive thatch accumulation is caused when the production of plant tissue exceeds its decomposition. This condition can be caused by excessive plant growth or during con-



Figure 7.7. Excessive thatch (left), good thatch amount (right).

ditions when plant tissue decomposition is slow. Excessive thatch layers impede the movement of moisture, nutrients and air into the root-zone soil. This condition leads to shallow root development, which may cause the turf to thin. Thatch formation is retarded through proper mowing, fertilization, watering and responsible pesticide use.

Determine the thickness of the thatch layer by examining a 3- to 4-inch deep plug. If thatch is thicker than 0.5 inch, a dethatching operation is needed. The best time to dethatch warm-season lawns of Bermuda grass and zoysiagrass is prior to spring green-up. Dethatch tall fescue and bluegrass lawns in the early fall. Thatch layers are best removed by a dethatching machine or power rake, which may be hired or rented. For more information concerning thatch and its control, see Fact Sheet HLA-6604, *Thatch Management in Lawns*.

Aerification

Turfgrass plants absorb oxygen and emit carbon dioxide through root surfaces. An adequate amount of air space in the soil is needed to provide aeration and proper soil water movement into and through the soil. With heavy use, the upper 2 to 3 inches of soil may become compressed into a denser, hard soil mass, restricting air and water movement. This is called soil compaction. Hard, tight, clay soils also impair the movement of air and water into and through the root-zone soil. In both situations, root growth is restricted, leading to a shallow-rooted turfgrass unable to withstand the stresses of traffic, extreme temperatures and low moisture.

The remedy for compacted soils or hard, tight clay soils involves the removal of 0.5- to 1-inch diameter cores to a depth of at least 2 inches. This practice is called core cultivation or aerification. Normally, a machine inserts a hollow metal tine or spoon into the soil and extracts a core from the turf. The length of the cores will vary due to soil strength and penetration capacity of the coring device, but they should be at least 2 inches in length for effective aeration. Adding weight to the machine and wetting the upper 4 to 6 inches of soil one to two days prior to core cultivation will aid in the penetration of metal tines or spoons. At least two passes should usually be made with the coring unit for each cultivation. Cores displaced on the surface should be allowed to dry. Incorporate the soil back into turf by hand raking or dragging a flexible steel door mat or piece of chain-link fence

over the area. Proper eye and ear protection as well as a dust mask may be necessary when dragging or breaking up cores. Following dragging, the small pieces readily disperse into the soil with additional irrigations or rainfall events.

Many lawns in Oklahoma would benefit from one or two core cultivations each year to improve the movement of air and water into the root-zone soil. Core cultivation also reduces excessive thatch layers. The best time to core cultivate is during periods of active plant growth. Core cultivate warm-season turfgrasses just prior to green-up in late winter or early spring and core cultivate cool-season turfgrasses early in the fall.

Weed control

Weeds interfere with the beauty and function of turfgrass areas, however, a small number of weeds in a lawn is usually tolerable. Weeds may indicate the turfgrass community has been weakened by some environmental condition, pests and/or improper maintenance activities. A healthy turfgrass is the best defense against weed infestation. Herbicides (herb means plant and -icide means killer of) are weed killers. They are important tools for controlling weeds in turf, but repeated severe occurrence of weeds may reflect underlying problems that need to be corrected so herbicidal control is not solely relied upon. The first step in weed control is a management program that produces a dense, vigorous, healthy turf of an adapted turfgrass variety by mowing, watering and fertilizing properly. Severe soil compaction or excess thatch also may be present, keeping the turf from being more competitive with weeds. Severe insect and disease attacks create openings in turf coverage that will allow additional levels of weed invasion. These problems should be controlled as they arise as a part of a normal turf management program.

Herbicides and terminology

Pre-emergence herbicides are effective in controlling crabgrass, foxtails, annual bluegrass, chickweed and a few other grassy and broadleaf weeds, depending on the herbicide. All must be applied prior to germination and "washed" into the root-zone soil, where weed seeds are located. Common pre-emergence herbicides include Dimension, XL, Surflan, Team, Hault, Haults, Pendulum and Barricade. These pre-emergent herbi-

cides are sometimes available in sprayable formulations and formulated on various herbicide and fertilizer combinations.

Post-emergence herbicides are applied following weed emergence when they are young and actively growing. Most are foliar absorbed, so they must remain on weed foliage for 24 to 48 hours following application. Selective post-emergence herbicides kill target weeds without injuring desirable plants, when applied at recommended rates and upon the species cleared for use on the specific herbicide labels. Post-emergent broadleaf herbicides include those with active ingredients of 2,4-D, dicamba and MCPP.

Weed identification and lawn grass identification

Proper weed identification is important as well as being able to identify the turfgrass species present in the lawn. Call upon the assistance of the local county Extension educator concerning proper weed and turfgrass identification. One cannot learn how to improve their management program for a certain weed unless the weed species can be identified; whether it is an annual, biennial or perennial; a cool-or warm-season; and if it is a grass, sedge, rush or broadleaf plant.

For those wanting to use an on-line tool in the form of a key with text and digital images to assist in turfgrass ID to the species level, the Turfgrass Identification Tool from the Turfgrass Program at Purdue University is available. This free ID tool is located at: <https://turf.purdue.edu/tool/> and it contains useful information to help identify any of the turfgrasses likely to be used in Oklahoma lawns. Another useful Turfgrass Identification Tool is available on-line and free of charge from the North Carolina State University Turfgrass Program at: <http://turfid.ncsu.edu/ItemID.aspx?orderID=GR&orderDesc=Grass>

There are many free weed identification tools available both from private industry and various Land Grant Universities around the U.S. One such site is the Turfgrass Weeds List ID tool offered by the University of Tennessee Turfgrass Program free on-line at: <http://www.tennessee-turfgrass-weeds.org/Pages/Weed-ID.aspx>. There are also apps for sale for the iPhone and Android systems at various app stores. A very useful turfgrass weed identification book also is available. *Weeds of Southern Turfgrasses* is durable enough to take to the field

and contains color images of more than 200 common turfgrass weeds. This guide is available for about \$14.00 from the on-line publication stores affiliated with Clemson University, the University of Georgia and the University of Florida.

Weeds and terminology

Annual weeds complete their life cycle in one growing season. They come back each year from seed. Crabgrass, goosegrass, foxtail and sandbur are summer annual grassy weeds. Knotweed and prostrate spurge are summer annual broadleaf weeds. For summer annual weed control with herbicides, apply a pre-emergence herbicide at least two weeks prior to the expected first germination of the target weeds. Water in the pre-emergent with two separate light applications of water totaling about 0.5 inches. If a pre- and a post-emergent herbicide have been applied together, read the labels to determine when the irrigation event should be applied for the best weed control from both components of the application. Crabgrass and foxtails are effectively controlled with pre-emergence herbicides applied before these weeds germinate. They start their germination in late February to early March in the southernmost counties of Oklahoma and up to 20 to 30 days later in the northern and panhandle counties, depending upon the weather conditions. Germination of summer annuals continues throughout the spring and summer months.

Depending on location and year, application of post-emergence herbicides should be performed soon after the emergence of crabgrass in April or May, while weeds are still small and actively growing. Post-emergence control of summer grassy weeds, such as crabgrass was formerly performed with organic arsenicals herbicides such as MSMA (example Ortho Crabgrass Killer Formula II, etc.). However, organic arsenicals are no longer being labeled for use in residential turf. Old products can still be used as per the label, but once it is used up, the newer MSMA products are labeled only for use on Golf Course, Sod Farms, roadside rights-of-way and cotton, and are not labeled for use in residential or commercial lawns.

In the absence of MSMA being available for post-emergent weed control in lawns, it is recommended to use Drive® 75DF, Drive® XLR8 or Quinclorac® 75DF, all of which contain quinclorac as an active ingredient. A methylated seed oil (MSO)

should be purchased and used per label directions to enhance activity of quinclorac products, compared to the activity of a non-ionic surfactant (NIS) that would normally be used with a post-emergent herbicide. Do not use dishwashing soaps or other household soaps as a wetting agents with pesticides. This is because these soaps are often ionic surfactants. Instead, purchase designated non-ionic surfactants from garden centers or pesticide distributors. Ionic surfactants can sometimes hinder rather than help herbicide performance and this is why non-ionic surfactants are recommended instead. Remember to read and follow all label directions on any pesticide. Herbicides are an example of a pesticide but not all pesticides are herbicides.

Image® herbicide, which contains active ingredient imazaquin, is labeled for consumer use in control of crabgrass as a post-emergent. Image® herbicide may not be labeled for use on all warm-season turfgrasses and should never be used on cool-season turfgrasses, so the label must be read to make certain the product is labeled for use on the specific turfgrass in question. Reading the label is an important step that cannot be overlooked.

There are many summer annual broadleaf weeds that can become problems in Oklahoma lawns. Generally, post-emergence control of summer broadleaf weeds is performed using properly labeled pre-mixes of products such as those containing 2,4-D; dicamba and MCPP. These products include those with the trade names of Trimec® and Weed-B-Gone®. At press time, the Bayer Advanced®, Spectracide® and Ortho® Product lines had pre-mix products that contained these active ingredients plus quinclorac, making the product useful for both post-emergent crabgrass and broadleaf weed control. **Remember to read and follow all labeled directions. Furthermore, remember that the label is the law concerning the proper use of every pesticide. Use of a pesticide in a manner inconsistent with its label may be consider a violation of federal law.**

Annual bluegrass, rescuegrass, cheat and downy brome are winter annual grassy weeds. Chickweed and henbit are winter annual broadleaf weeds. For winter annual weed control with herbicides, apply a pre-emergent herbicide at least two weeks prior to the first expected germination of the winter annual weeds. For instance, in the

north-central counties, winter weeds begin germination in late August to early September, if moisture is available. In southern counties, germination may not start until late September to early October. Annual bluegrass and chickweed are effectively controlled with pre-emergence herbicides. Some pre-emergence herbicides control both winter annual grasses and broadleaves. Portrait® or Gallery®, both of which contain the active ingredient isoxaben, provide good pre-emergence control of winter annual broadleaf weeds, but no control of winter annual grasses weeds.

Soon after their emergence in October and November, winter annual broadleaves can be killed with post-emergent broadleaf herbicides. The same broadleaf post-emergent herbicide used to control summer broadleaves are effective against winter annual broadleaves and, at the proper dose, against most perennial broadleaves. Examples again include Trimec® and Weed-B-Gone®, although many others are effective and available for the consumer.

Post-emergence control of winter broadleaf weeds in Bermuda grass, buffalograss, Kentucky bluegrass, centipedegrass, perennial ryegrass, tall fescue and zoysiagrass is with the mixes of 2,4-D®; dicamba and MCPP® combinations applied in October and November. A second option for control of winter annual weeds involves the application of Roundup® when the Bermuda grass is fully dormant (January or early February). This application is appropriate only in dormant Bermuda grass – not on other turfgrasses. The consumer is afforded the use of certain Roundup® products that contain the active ingredient glyphosate for use in winter annual weed control. A tank mix of a glyphosate herbicide and a broadleaf post-emergent herbicide over completely dormant Bermuda grass in January or early February (if allowed by the specific product labels) is highly effective in controlling winter annual grasses/winter annual broadleaves.

Perennial weeds have the capacity to reproduce by underground vegetative parts such as rhizomes, nutlets and bulbs. Generally, perennial weeds are more difficult to control than annual weeds because of their ability to regrow from underground plant parts. Dallisgrass, dandelion, clover and nutsedge are perennial weeds.

Yellow nutsedge can be partially controlled in Bermuda grass and zoysiagrass by applying Pennant® preemergence herbicide (active ingre-

dient metalochlor) in late March-early April prior to germination of dormant nutlets. Control yellow nutsedge in late April, May or June with post-emergence applications of Basagran® T/O (active ingredient bentazon). Repeat applications will be necessary throughout the season. Also, the consumer may also use Image herbicide (active ingredient imazaquin) or Certainty® herbicide (active ingredient sulfosulfuron) post-emergence for yellow or purple nutsedge control in certain warm-season turfgrasses, but not in most cool-season turfgrasses. Sedgehammer® (active ingredient halosulfuron) may be used for yellow or purple nutsedge post-emergence control in most cool or warm-season turfgrasses. Be sure to read the label to know which turfgrass species the product is cleared for use upon. Some herbicides suitable for use in warm-season turfgrass management are deadly to cool-season turfgrasses, such as tall fescue. Additionally, St. Augustinegrass can sometimes be sensitive to herbicides otherwise labeled and useful on Bermuda grass and zoysiagrass.

Control perennial broadleaves such as dandelions and clover in Bermuda grass, Kentucky bluegrass, centipedegrass, perennial ryegrass, tall fescue and zoysiagrass in October and November with 2,4-D®, Banvel® and MCPP® combinations applied post-emergence.

Nonselective post-emergence herbicides kill all actively growing plants. Examples include Roundup®, Roundup Pro®, GLYFOS®, Kleenup®, Finale®, Diquat® and various weed and grass killer formulations.

Although it has been said several times in this section, always read and follow all pesticide label instructions. For more detailed information on controlling weeds in turf with herbicides, see Fact Sheet HLA-6601, *Broadleaf Weed Control for Lawns in Oklahoma*.

Insect control

Many kinds of insects or insect-like pests harbor in lawns. Most are more of a nuisance rather than actually causing serious damage to lawns. Occasionally, populations of grubs, armyworms, sod webworms, aphids, leafhoppers and pillbugs become large enough to require control. For strategies and a complete list of lawn insects and their control see Fact Sheet EPP-7306 *Ornamental and Lawn Pest Control*.

Disease control

Turfgrasses vary in their susceptibility to disease. Bermuda grass is one of the most resistant grasses, although it is more or less susceptible to the fungal disease Spring Dead Spot in Oklahoma. Non-improved common Bermuda grasses such as Arizona common and most common Bermuda grasses sold as U-3 are somewhat susceptible to Dollarspot diseases in late spring and early fall when heavy dew is present. The most serious fungal diseases of tall fescue are Large Brown Patch, Rhizoctonia blight and Pythium blight. Most diseases can be controlled early during the disease symptom expression phase with the appropriate fungicides. Spring Dead Spot disease control in Bermuda grass is much more complex however. Use of resistant cultivars is the first step in any disease control strategy followed by proper management of the grass with proper mowing, fertilization, irrigation and aerification, with dethatching as needed. Still a fungicide program may be needed with certain circumstances.

For a complete list of lawn diseases and their control, see Fact sheets EPP-7637 *Home lawn Disease Control Guide*, EPP-7658 *Dollar Spot of Turfgrass*, and EPP-7324 *Large Patch of Warm-Season Turfgrasses*.

Chapter 8: ENTOMOLOGY BASICS

Learning Objectives:

After completing this section, Master Gardener trainees will be able to:

- Identify insects to the order level of classification based on shared characteristics.
- Identify common signs and symptoms of arthropod pests.
- Identify common beneficial insects in the garden.

Chapter 8: Entomology Basics.....	333
Introduction	333
Arthropod Classification	334
Species.....	334
Malacostraca.....	335
Archnida	335
Chilopoda	335
Diplopoda.....	336
Insecta.....	336
Insect Development	336
Insect Morphology (Form & Structure)	337
Mouthparts	337
Wings.....	338
Antennae	339
Insect Identification	339
Coleoptera.....	340
Diptera.....	341
Hemiptera.....	341
Hymenoptera.....	341
Lepidoptera	341
Orthoptera	341
Dermaptera	342
Neuroptera.....	342
Thysanoptera.....	342
Other insect orders.....	342
Damage to Plants from Insects and Mites	342
Chewing damage	342
Sucking damage	343
Plant galls	343
Oviposition damage	344
Vectors of Diseases.....	344
Beneficial Insects	344

Introduction

Arthropods are some of the most interesting creatures, owing to their incredible diversity in both form and function and because they are among the most abundant, diverse and successful organisms on Earth. Approximately 75 percent of all known animal species are arthropods, and the vast majority of these are insects (Figure 8.1). Indeed, ants alone make up 10 percent of the world's biomass and are present virtually everywhere. Beetles are so diverse that of every animal species known to science, 1 in 5 belongs to one family, the weevils

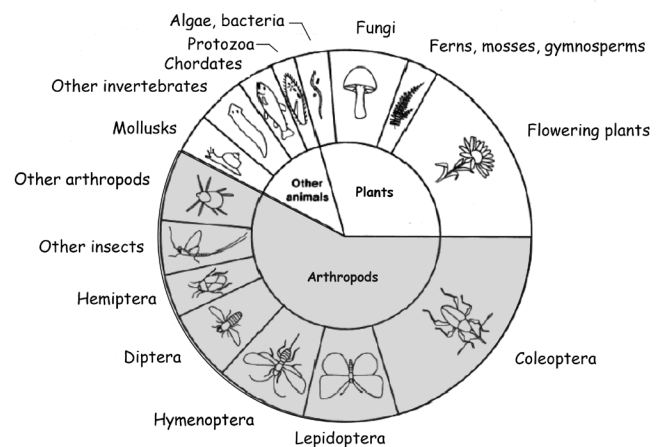

Figure 8.1. The diversity and relative abundance of living organisms.

(Family Curculionidae). An estimated 100,000 species of insects and mites can be found in North America, and the typical backyard contains hundreds of species at any given time. However, only a small fraction are observed on a frequent basis because many are microscopic and/or hidden belowground or within plant tissue.

Fortunately, less than 2 percent of all insect species are classified as pests, whether they feed on plants or plant products, invade our homes, inflict painful bites and stings or transmit diseases. Most insects are either “neutral” or beneficial and serve a variety of important functions such as food for other animals (including humans), decomposers of organic matter, pollinators, natural enemies (predators and parasitoids) and producers of shellac, dye, wax, honey and silk.

Why study insect science? Of course, one reason is sheer appreciation for one of the planet’s dominant and most interesting life forms, but just as significant one should know at least the basics of entomology to best manage them when they compete with us for food and fiber, or become a nuisance or health threat. In any battle, knowing your adversary gains a great advantage. Thus, the first step in managing insect pests is to identify them correctly. Proper identification will lead to better understanding of the biology and life history of the insect, which may be useful for exploiting its weaknesses. Importantly, correct identification can tell us whether the insect we are dealing with is truly a pest or one of the many neutral or beneficial insects that inhabit our landscapes.

Once a pest is correctly identified, the next step is to determine whether we have done (or failed to do) anything to the landscape that created the pest problem. Many pest problems can be prevented by planning ahead and minimizing plant stress, which makes plants more susceptible to insects and pathogens. Thus, “pre-emptive gardening” for pest prevention requires a thorough knowledge of the landscape and the plants therein. Good overall horticultural practices include selecting the right plants, planting them in the proper site and providing them with adequate fertilizer and water. It also is a good idea to learn which plants are favored by certain pests. For example, junipers or cedars are almost certain to come under attack from bagworms at some point. Knowledge of the pest and the landscape also provide a solid foundation for selecting the proper pest control tools. Addition-

ally, selecting the appropriate pest treatment can have economic and environmental benefits.

Arthropod Classification

Identification of animals, plants and other life forms would be impossible without a standard system of classification. Scientists classify all organisms according to their appearance or relatedness. Thus, all living things are grouped into different categories (called taxa) based on shared physical characteristics and/or genetic material (DNA). Taxa are arranged hierarchically as follows:

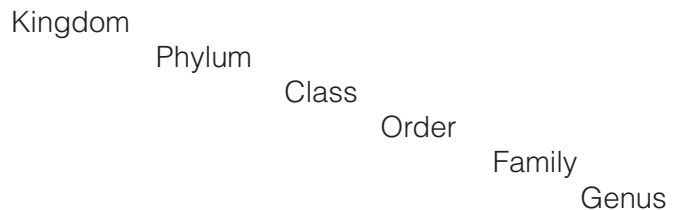

Species

Kingdom is the broadest level of classification. For example, all animals are classified under the Kingdom Animalia. On the other end of the spectrum, genus and species are the finest levels of classification. The Phylum Arthropoda includes insects and their relatives, which are all animals that have several characteristics in common:

- skeleton on the outside of the body (i.e., exoskeleton),
- distinct body segmentation,
- paired, jointed appendages,
- dorsal, tubular heart valves,
- ventral, double nerve chord and
- open circulatory system.

All arthropods have an exoskeleton, which serves as an attachment for muscles, for protection of the arthropod’s organs and protection from the environment. It must be shed periodically throughout their lifetime through a process called ecdysis (molting). The exoskeleton is rich in chitin, a protein that makes the outer body rigid. The exoskeleton also protects arthropods from desiccation and infection, and serves as an internal point of attachment for muscles and other tissues. All arthropods are distinctly segmented, similar to the segmented bodies of earthworms. The appendages, includ-

ing legs, wings and mouthparts, are paired on either side of the body segment to which they are attached, giving the body a symmetrical appearance. The appendages are also jointed in several places (Arthropoda literally means “jointed foot or appendage”), allowing the rigid exoskeleton to articulate and provide movement. The arthropod “heart” is actually a series of tubular valves located along the back (top) of the body, whereas the double nerve chord runs along the belly (bottom). Finally, the circulatory system is an “open” system, meaning there are no veins, arteries, capillaries or other tissues for channeling the blood. Rather, the interior body is an open cavity and internal organs are bathed in the blood. Arthropods do not have lungs. They acquire oxygen and expel carbon dioxide through special pores in the exoskeleton called spiracles.

Arthropods are grouped into their respective classes based on other shared features such as the number of body segments, pairs of legs and pairs of antennae (Table 8.1).

Malacostraca

This is a class of the subphylum, Crustacea, which includes sowbugs, pillbugs, crayfish, crabs and lobsters. Sowbugs and pillbugs are the only terrestrial crustaceans and are commonly encountered in the garden and around the home. Mem-

bers of the Class Malacostraca share the following characteristics:

- two main body regions, the cephalothorax (head fused with thorax) and abdomen,
- some have two pairs of antennae (others have only one pair) and
- five to seven pairs of legs.

Arachnida

The Class Arachnida includes spiders, mites, ticks, scorpions, and harvestmen, which share the following characteristics:

- two main body regions, the cephalothorax and abdomen,
- no antennae,
- no wings and
- four pairs of legs.

Chilopoda

This arthropod class consists of centipedes, which are swift runners and predaceous (predatory). All centipedes share the following characteristics:

- two main body regions, the head and trunk,
- dorso-ventrally flattened (like a pancake),
- long, segmented body,
- one pair of antennae and
- one pair of legs attached to body segments of the trunk.

Table 8.1. Major classes of arthropods and shared characteristics used for classification.

<i>Class</i>	<i>Examples</i>	<i>Body regions</i>	<i>Pairs of legs</i>	<i>Pairs of antennae</i>	<i>Pest status</i>
Malacostraca	crayfish, sowbugs	2	5	2	Sowbugs and pillbugs are terrestrial crustaceans and can be minor nuisance pests.
Arachnida	spiders, mites, ticks	2	4	0	Some mites are major plant pests and many ticks transmit diseases to humans and livestock.
Chilopoda	centipedes	2	1 per body segment	1	Some can inflict a painful bite.
Diplopoda	millipedes	2	2 per body segment	1	Millipedes can be minor nuisance pests.
Insecta	true bugs, beetles, butterflies	3	3	1	Many are important pests.

Diplopoda

The Class Diplopoda consists of millipedes. Unlike their close relatives, the centipedes, millipedes move slowly and are decomposers. All millipedes share the following characteristics:

- two main body regions, the head and trunk,
- generally rounded body,
- long, segmented body,
- one pair of antennae and
- two pairs of legs attached to body segments of the trunk.

Insecta

Members of the Class Insecta are the true insects, which share the following characteristics:

- three body regions, the head, thorax, and abdomen,
- three pairs of legs attached to the thorax,
- one or two pairs of wings (or none) attached to the thorax and
- one pair of antennae.

There are many different types of insects and they can be grouped into different orders based on other shared features. Most adult insects are identified to order quite easily by observing the number and type of wings, type of mouthparts, and mode of development (Table 8.2). Insects are further subdivided into family, genus and species, which

require specialized training beyond the scope of this chapter.

Insect Development

The exoskeleton provides many advantages to insects, but it must be shed regularly as the insect feeds and grows. A disadvantage of the exoskeleton is that molting insects are more vulnerable to natural enemies and the environment. Insect development, or metamorphosis, has evolved in four distinct ways (Figure 8.2).

Ametabolous development literally means “without change,” referring to the fact that insects undergoing this type of metamorphosis only change in size, not form. Immatures are referred to as nymphs and develop through several instars (stages) before becoming adults. Adults never have wings and resemble larger versions of the nymphs. Examples of common ametabolous insects include silverfish and springtails.

Paurometabolous development, or gradual metamorphosis, is also characterized by three life stages: egg, nymph and adult. Paurometabolous insects change in both size and form as they develop. Specifically, first-instar nymphs hatch with wing buds protruding from the thorax, which grow into ever larger wing pads with each successive molt. The wings become fully elongated and func-

Table 8.2. Some familiar orders of the Class Insecta.

<i>Order</i>	<i>Common name</i>	<i>Metamorphosis</i>	<i>Mouthparts (adults)</i>	<i>Pairs of wings</i>
Coleoptera	beetles	complete	chewing	2
Dermaptera	earwigs	gradual	chewing	2
Diptera	true flies	complete	chewing or piercing-sucking	1
Hemiptera	true bugs	gradual	piercing-sucking	2
Hymenoptera	ants, bees, wasps	complete	chewing	2 or none
Isoptera	termites	gradual	chewing	2
Lepidoptera	butterflies, moths, skippers	complete	siphoning	2
Orthoptera	crickets, grasshoppers	gradual	chewing	2
Neuroptera	lacewings, ant lions	complete	chewing	2
Siphonaptera	fleas	complete	chewing or piercing-sucking	none
Thysanura	silverfish, firebrats	gradual	chewing	none
Thysanoptera	thrips	gradual	rasping-sucking	2

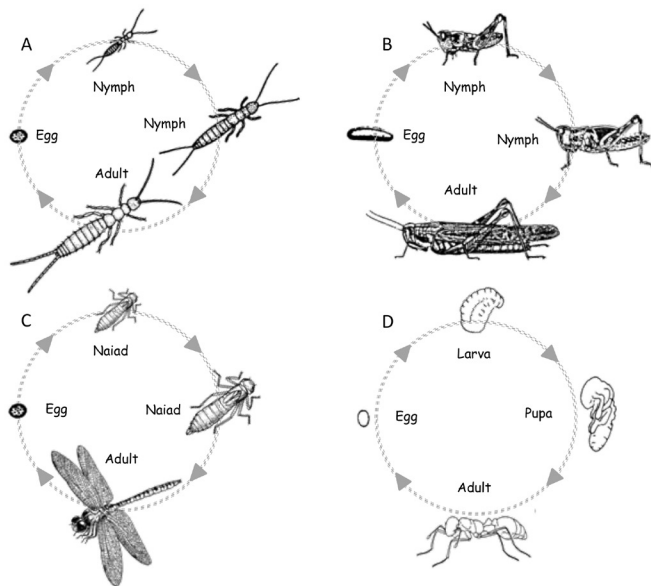

Figure 8.2. Types of insect development: A) ametabolous; B) paurometabolous (gradual); C) hemimetabolous (simple); D) holometabolous (complete).

tional following the final molt into an adult. Common paurometabolous insects include grasshoppers, cockroaches and plant bugs.

Hemimetabolous development, or simple metamorphosis, is similar to gradual metamorphosis except the immatures live underwater and are called naiads. Dragonflies, damselflies and mayflies are common examples of hemimetabolous insects.

Holometabolous development, or complete metamorphosis, is characterized by four life stages: egg, larva, pupa and adult. Immatures, called larvae, are somewhat worm-like and molt through several instars before forming a pupa. During pupation, the body changes drastically and the adult insect emerges with legs, antennae and, with a few exceptions, wings. Insects such as ants, wasps, flies, and beetles (and many more) are holometabolous.

Insect Morphology (Form and Structure)

Insect identification depends greatly on a thorough understanding of insect morphology (form and structure). The shape, length and form

of mouthparts, wings, antennae, legs and other structures are used to identify insects to order, family and lower taxonomic levels.

Mouthparts

Mouthparts can be especially useful for identifying insect orders and indicate the type of food they consume (Figures 8.3 through 8.5). The most primitive mouthparts are chewing mouthparts. Thus, ancestral arthropods had chewing mouthparts similar to that observed in many modern-day insects like beetles and grasshoppers. Chewing mouthparts are comprised of four main appendages: a fused labrum (upper lip); mandibles; maxilla; and a fused labium (lower lip) (Figure 8.3). The maxilla and labium are equipped with antenna-like structures called palps, which allow the insect to taste, smell and feel potential food sources. Other types of mouthparts are modifications of the primitive chewing mouthpart design, adaptations which allow some insects to specialize on other diets. All appendages associated with chewing mouthparts are present in these modified mouthpart designs, but are rearranged and modified in different ways. Piercing-sucking mouthparts allow insects to feed on liquid diets. There are different kinds of piercing-sucking mouthparts (Figure 8.4), but in general, consist of a straw-like mechanism that is inserted into animal or plant tissue to extract blood or plant sap, respectively. Other mouthpart modifications include chewing-lapping, sponging, siphoning and rasping-sucking (Figure 8.5).

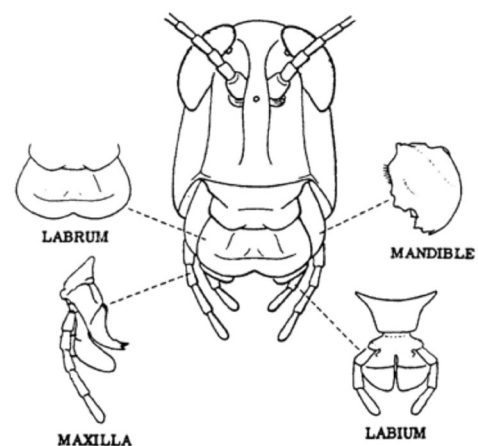

Figure 8.3. Chewing mouthparts with cutaway images showing major appendages: labrum (upper lip), mandibles, maxilla and labium (lower lip).

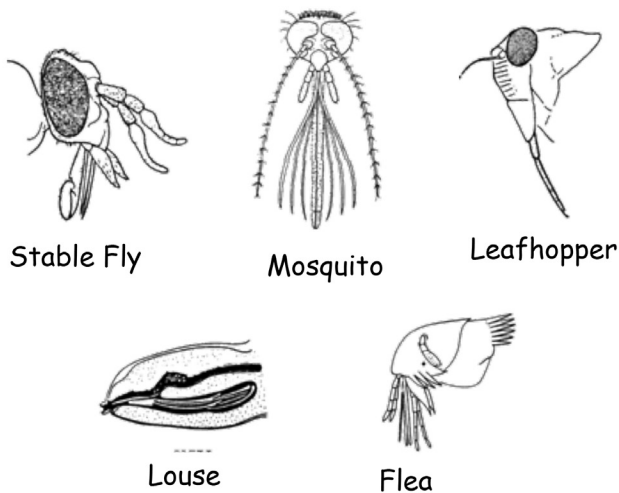

Figure 8.4. Piercing-sucking mouthparts of representative insects. These various mouthpart designs allow the insect to feed on a liquid diet, chiefly blood and plant sap.

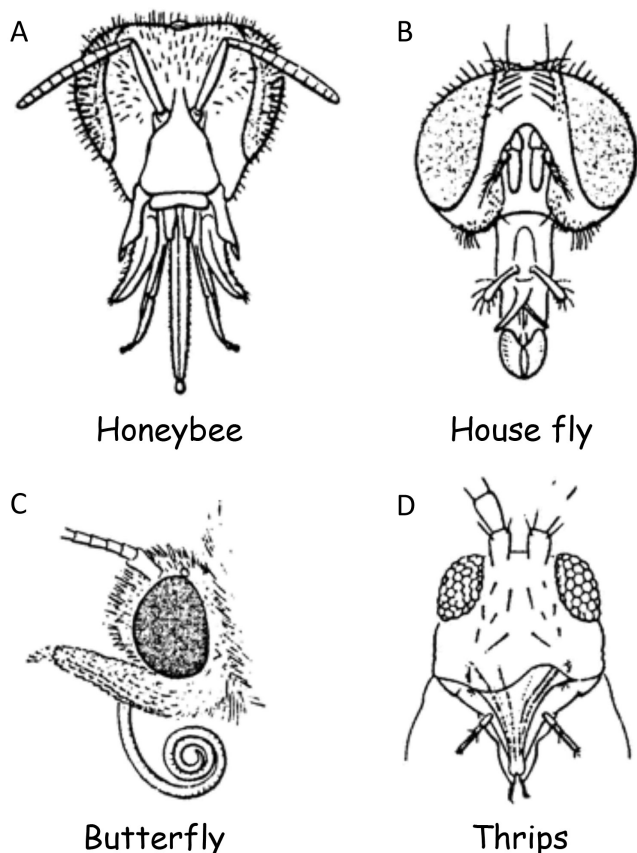

Figure 8.5. Representative insects depicting other mouthpart types including: A) chewing-lapping; B) sponging; C) siphoning; and D) rasping-sucking.

Wings

Wing number and type are two very important characteristics for correct identification of insects to order (Table 8.2, Figure 8.6). The most primitive insects like silverfish and springtails, for example, undergo ametabolous development and are completely wingless throughout their lives. However, several more advanced insects may or may not have wings, depending on their caste, sex or generation. For example, worker (non-reproductive) ants do not have wings, whereas reproductive ants develop wings when crowding or other conditions require them to disperse and form a new colony. Velvet ants, which are actually wasps, are characterized by having winged males and wingless females. Aphids may be winged or wingless, depending on their generation. Wings are present in generations of aphids that must disperse to a new host plant for feeding or overwintering. Most other insects have two pairs of wings, although true flies (Order Diptera) only have one pair of membranous wings. In reality, flies have two pairs of wings, but the second, hind pair is reduced to specialized, knob-like structures called halteres that enable these acrobatic fliers to orient themselves in flight.

For insects with two pairs of wings, wing type is a useful diagnostic tool. There are five basic types of wings (Figure 8.6). Beetles (Order Coleoptera) have front wings that are modified into hardened sheaths (elytra). The hind wings, used for flight, are membranous and concealed beneath the elytra when the beetle is not in flight. Another wing mod-

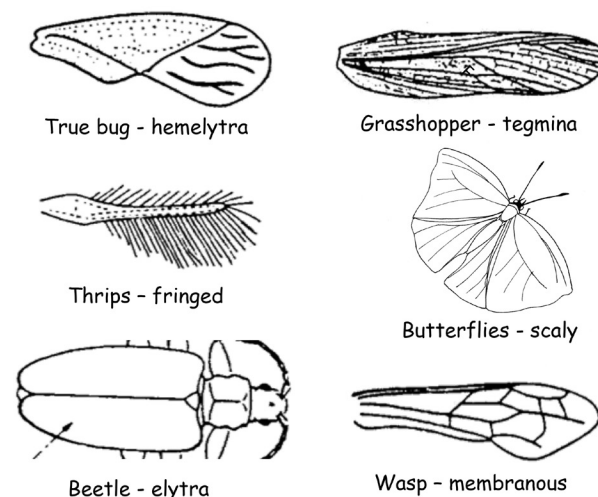

Figure 8.6. Major wing types and representative insects possessing those wings.

ification is seen with true bugs, members of the Order Hemiptera. True bugs, which include stink bugs and squash bugs, possess hemelytra (meaning “half-winged”). These modified front wings are divided into two portions, a membranous and a hardened portion. Like beetles, true bugs have a membranous pair of hind wings used for flight that are folded below the hemelytra. Members of the Order Orthoptera, which include grasshoppers and crickets, have leathery wings called tegmina. Praying mantids (Order Mantodea), cockroaches (Order Blattodea), and walking sticks (Order Phasmoda) also have tegmina. Thrips (Order Thysanoptera) are very tiny insects with tapered bodies and two pairs of wings that are fringed with hairs. Scale-winged insects include butterflies, moths and skippers (Order Lepidoptera). Their wings are made of microscopic scales that often are very colorful. Finally, insects like dragonflies and damselflies (Order Odonata), mayflies (Order Ephemeroptera), bees and wasps (Order Hymenoptera), lacewings (Order Neuroptera) and true flies (Order Diptera) have membranous wings.

Antennae

Antennae are highly diverse among insects, even within orders and families (Figure 8.7 shows just a few examples). Thus, they are not very useful diagnostic features for identifying insects to order.

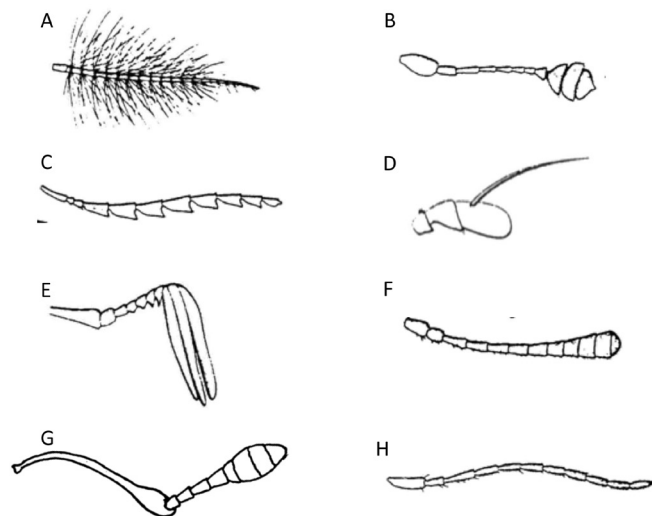

Figure 8.7. Some of the many types of antennae seen in insects: A) plumose; B) capitate; C) serrate; D) aristate; E) lamellate; F) clavate; G) genuiculate; and H) filiform.

Legs

Legs have been greatly modified in certain insects to allow them to survive in a wide variety of environments. The most dramatic of these adaptations are seen in the front and hind pairs of legs (Figure 8.8). Briefly, these leg modifications include jumping (saltatorial), grasping (raptorial), running (cursorial), swimming (natatorial), digging (fossorial) and clinging. Certain bees, which are important pollinators, possess pollen baskets (corbicula) on the hind legs for collecting pollen. Leg type can be of occasional importance in identifying insects to order. For example, grasshoppers and crickets (Order Orthoptera) are recognizable by their massive hind legs modified for jumping.

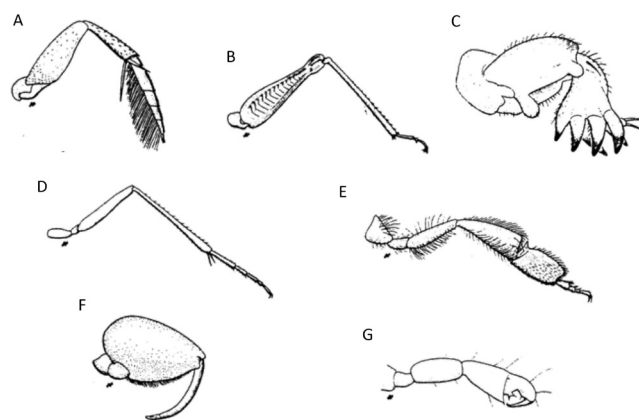

Figure 8.8. Some of the many types of legs seen in insects: A) natatorial (swimming); B) saltatorial (jumping); C) fossorial (digging); D) cursorial (running); E) corbicula (pollen basket); F) raptorial (grasping); and G) clinging.

Insect Identification

Several insect orders are encountered in the garden and other home landscapes (Figure 8.9). Members of these orders contain both pests and beneficial insects such as pollinators and natural enemies (predators and parasitoids). With a bit of practice, these common insects can be identified easily by gardeners and homeowners. For more information on common insect pests of Oklahoma gardens and ornamental landscapes, see Oklahoma Cooperative Extension Service publication E-918: *Major Horticultural and Household Insects of Oklahoma*. For more information on common

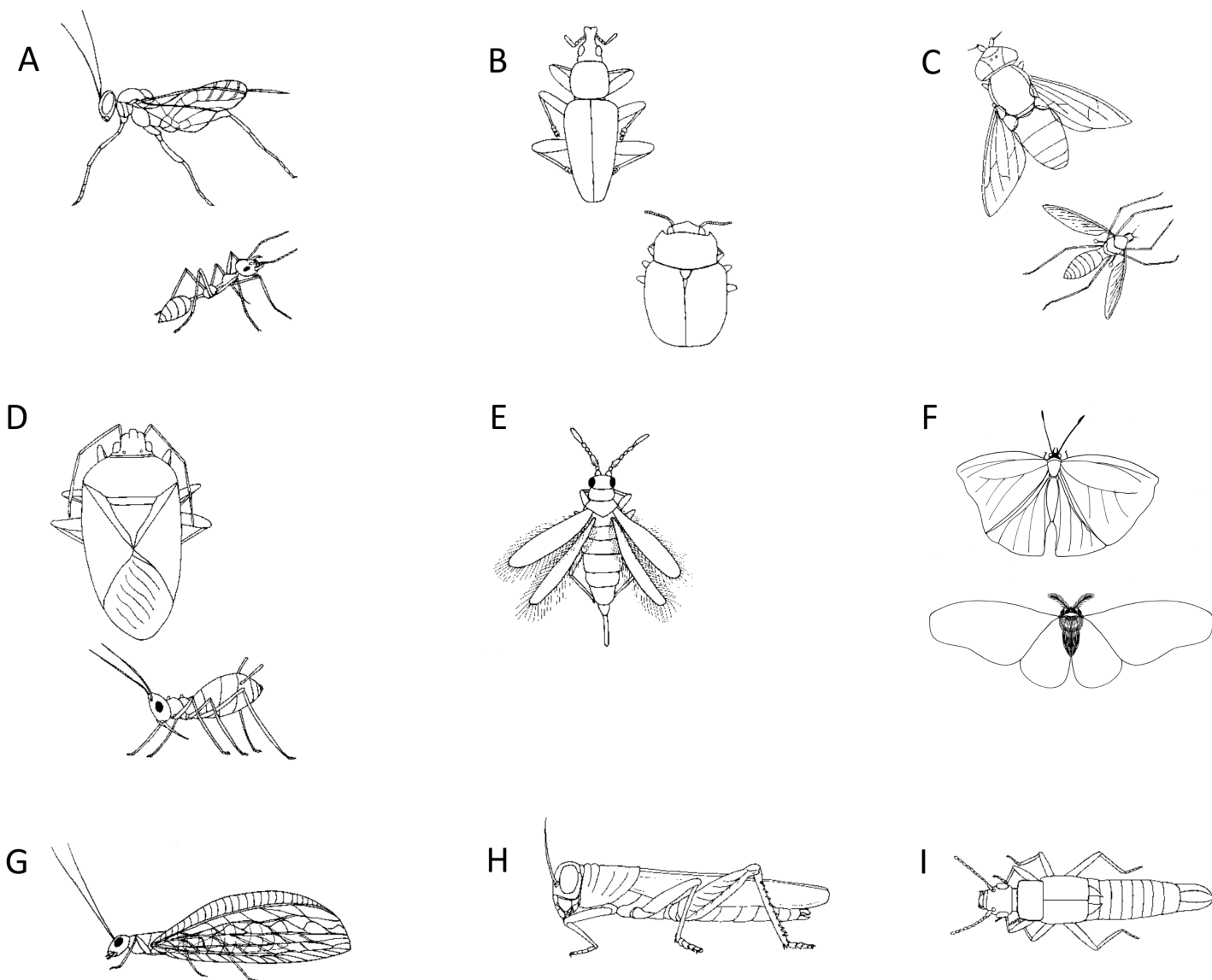

Figure 8.9. Some common orders of insects encountered in the garden: (A) Hymenoptera (ants, bees and wasps); (B) Coleoptera (beetles); (C) Diptera (true flies); (D) Hemiptera (true bugs, aphids, cicadas); (E) Thysanoptera (thrips); (F) Lepidoptera (butterflies, moths); (G) Neuroptera (lacewings, antlions); (H) Orthoptera (grasshoppers and crickets); and (I) Dermaptera (earwigs) (Drawings by Katrina Menard, Ph.D., Sam Noble Natural History Museum, Oklahoma University).

insect natural enemies of Oklahoma pests, see Oklahoma Cooperative Extension Service publication *E-1023: Conserving Beneficial Arthropods in Residential Landscapes*.

Coleoptera

Coleoptera contains all beetles, including weevils, and most share the following characteristics:

- adults have two pairs of wings, the outer (front)

pair hardened (elytra) and the inner (hind) pair membranous (flying wings),

- chewing mouthparts,
- adults have a wide variety of antennae,
- larvae/grubs with head capsule, most with three pairs of legs on thorax, no legs on the abdomen and
- complete metamorphosis (holometabolous development).

Diptera

Diptera contains all true flies, including house flies, gnats, and mosquitoes, and most share the following characteristics:

- adults have only one pair of membranous flying wings (front) and a pair of halteres that are really modified hind wings,
- adults have various mouthparts, including sponging (house fly) and piercing-sucking (female mosquito),
- larvae may have hook-like mouthparts or chewing mouthparts.
- most larvae are legless and maggot like.
- larvae of advanced forms (house flies and relatives) have no head capsule, while less advanced forms (mosquitoes) have a head capsule and
- complete metamorphosis (holometabolous development).

Hemiptera

Hemiptera is divided into three suborders, Suborder Heteroptera (true bugs), Suborder Sternorrhyncha (aphids, scales, mealybugs and whiteflies) and Suborder Auchenorrhyncha (cicadas and hoppers). Heteroptera (true bugs) share the following characteristics:

- adults have two pairs of wings, the outer (front) pair half membranous and half hardened (hemelytra) and the inner (hind) pair membranous (flying wings),
- piercing-sucking mouthparts,
- adults have a large triangular plate (scutellum) between the base of the wings (just behind the head),
- nymphs resemble adults, except they do not have fully formed wings and
- gradual metamorphosis (paurometabolous development).

Sternorrhyncha (aphids, scales, mealybugs and whiteflies) share the following characteristics:

- small, soft-bodied insects, although scale insects secrete a hard or waxy body covering,
- may be winged or wingless forms; when wings are present, there are two pairs and are usually held roof-like over body when at rest,
- piercing-sucking mouthparts,
- many excrete honeydew as waste product and
- gradual metamorphosis (paurometabolous development).

Auchenorrhyncha (cicadas and hoppers) share the following characteristics:

- hard-bodied, and large (cicadas) or small to minute (hoppers),
- large, membranous wings (cicadas) or thickened wings (hoppers),
- short, bristle-like antennae,
- piercing-sucking mouthparts and
- gradual metamorphosis (paurometabolous development).

Hymenoptera

Ants, bees and wasps belong to the order Hymenoptera. Except for reproductive adults, ants are wingless. Most members of the order share the following characteristics:

- adults have two pairs of membranous wings; front wings are larger than hind wings,
- larvae are legless (ants, bees, and wasps), or three pairs of legs present on thorax and some with more than five pairs of fleshy prolegs on abdomen (sawflies),
- chewing mouthparts (or chewing-lapping as seen with bees),
- females with modified ovipositor (egg-laying organ) that forms a stinger and
- complete metamorphosis (holometabolous development).

Lepidoptera

Lepidoptera is comprised of butterflies, moths and skippers, which are easily recognizable insects and favorites among collectors. Most members of the order share the following characteristics:

- adults are soft-bodied,
- adults have two pairs of well-developed, scaly wings,
- adults have coiled mouthparts (siphoning) and feed on nectar; larvae have chewing mouthparts,
- larvae have three pairs of legs present on thorax and three to five pairs of fleshy prolegs on abdomen and
- complete metamorphosis (holometabolous development).

Orthoptera

Orthoptera include grasshoppers and crickets and share the following characteristics:

- adults are moderate to large, and somewhat hard bodied,

- adults usually have two pairs of wings, the front wings (tegmina) are leathery and thickened and the hind wings are membranous (flying wings),
- chewing mouthparts,
- hind legs may be modified for jumping,
- nymphs resemble adults, except they do not have fully formed wings and
- gradual metamorphosis (paurometabolous development).

Dermaptera

Dermaptera are the earwigs and all share the following characteristics:

- adults are moderately sized and hard bodied,
- chewing mouthparts,
- elongated, flattened insects with strong, movable, forceps-like cerci on abdomen,
- short, hardened outer (front) wings (elytra) and folded, membranous inner (hind) wings (flying wings),
- adults and nymphs similar in appearance and
- gradual metamorphosis (paurometabolous development).

Neuroptera

Lacewings, antlions, mantisflies, snakeflies, dobsonflies and dustywings all belong to the Order Neuroptera. Most members of the order share the following characteristics:

- two pairs of membranous wings with many veins that resemble a nerve network,
- adults have chewing mouthparts, larvae have sickle-shaped mandibles and suck blood from prey,
- complete metamorphosis (holometabolous development),
- most are predators as adults and larvae and
- some are aquatic.

Thysanoptera

Thysanoptera are the thrips and all share the following characteristics:

- adults are small, soft-bodied insects,
- two pairs of slender wings fringed with hairs,
- mouthparts are rasping-sucking and
- varied metamorphosis, a mixture of complete and gradual.

Other insect orders

Several other insect orders are listed in Table 8.3. Some of these may be encountered in and around the home.

Damage to Plants from Insects and Mites

Insects and their relatives can damage plants in many ways as both adults and juveniles. Feeding activity often causes the most recognizable injury to landscape plants, but behaviors such as oviposition (egg laying), nesting and gall making can alter plant aesthetics and health. Damage to plants can occur both aboveground and belowground, internally and externally, and to vegetative and reproductive tissues.

Chewing damage

Chewing insects can cause damage by biting off external tissues of a plant. Chewing damage is so prevalent in landscapes, it is often difficult to find plants without at least some leaf tissue removed by chewing insects. Cabbageworms, armyworms, grasshoppers, Japanese beetles and fall webworms are common examples of chewing insect pests. In severe outbreaks of these pests, foliage may be missing entirely from affected plants. Larvae of some insects (e.g., elm leaf beetle, willow leaf beetle) remove cellular layers of leaf tissue, giving leaves a “skeletonized” appearance. Adult Japanese beetles will also skeletonize leaf tissue. Some insects such as black vine weevil may remove only small notches from leaf margins. Leaf cutter bees leave behind larger, circular holes at the leaf margin and use the removed leaf tissue for fashioning cells in nests.

Chewing insects can also cause internal damage to plants. Woodborers, leaf miners and many fruit pests have chewing mouthparts to feed and tunnel internally on plants. Damage by these pests occurs during their immature life stages. They enter host plants either as eggs deposited by adult females or by chewing their way into woody and herbaceous tissues. In either case, the entrance hole is usually very small and practically invisible. Large holes encountered in fruits, seeds, stems, trunks or twigs indicate where the adult insect emerged following feeding and development with-

Table 8.3. Other Insect Orders.

<i>Order</i>	<i>Examples</i>	<i>Type of Development</i>
Blattodea	Cockroaches, Termites	Paurometabolous
Collembola	Springtails	Ametabolous
Embiidina	Webspinners	Paurometabolous
Ephemeroptera	Mayflies	Hemimetabolous
Mantodea	Praying mantids	Paurometabolous
Mecoptera	Scorpionflies	Holometabolous
Odonata	Dragonflies, Damselflies	Hemimetabolous
Phasmida	Walking sticks	Paurometabolous
Phthiraptera	Lice	Paurometabolous
Plecoptera	Stoneflies	Hemimetabolous
Psocoptera	Booklice, Barklice	Paurometabolous
Siphonaptera	Fleas	Holometabolous
Thysanura	Silverfish	Ametabolous
Trichoptera	Caddisflies	Holometabolous
Zoraptera	Angel insects	Paurometabolous

in the plant. Leaf miners are small enough to find comfortable quarters between the upper and lower epidermis of a leaf. Their feeding and mining activity results in either discolored, serpentine runs throughout the leaf or in large, whitish blotches filled with frass (excrement). Mining continues until the insect pupates and emerges as an adult.

Sucking damage

Plant damage can also occur from insects with piercing-sucking mouthparts. These insects insert their straw-like mouthparts into plant tissues and either feed on sap flowing through vascular tissues or feed on the liquid contents of burst cells. This feeding behavior results in small, discolored spots called stippling, where the piercing-sucking mouthparts were thrust into the plant and sap was removed. These small spots can coalesce into larger blotches as the insect population grows and feeding continues. Sucking damage can manifest as discolored leaves, fruits and twigs; curled leaves; deformed fruit; and wilting, browning and eventual death of the plant. Aphids, scales, squash bugs and leafhoppers are commonly encountered sucking pests. Although not insects, spider mites and other plant-feeding mites have stylet-like mouthparts that pierce plant tissues and cause stippling. Damage from sucking pests will

often show up as chlorotic spots, gradually turning yellow then brown.

Plant galls

Many galls observed on landscape plants are caused by the feeding activity of chewing and sucking insects. Certain chemicals produced by these insects mimic plant-growth hormones, inducing abnormal growth of plant tissue (i.e., gall formation) at the feeding site. Galls may be caused by phylloxerans, cynipid wasps (and other tiny Hymenoptera), gall midges, psyllids and some species of mites (e.g., eriophyid mites). Galls serve as both shelter and food for developing immature insects. Although the gall is entirely plant tissue, the developing insect controls and directs the form and shape it takes as it grows. Gall-forming arthropods are difficult to control. Fortunately, most leaf galls only reduce the aesthetic quality of affected plants. A couple notable exceptions include twig galls such as gouty oak gall and horned oak gall, which are caused by cynipid wasps and can be harmful or even fatal to several species of oaks (e.g., pin oak, blackjack oak). For more information about plant galls see Oklahoma Cooperative Extension Service publication *EPP-7168: Plant Galls Caused by Insects and Mites*.

Oviposition damage

Nearly 95 percent of insect injury to plants is caused by feeding in the various ways described thus far. Insects can also injure plants by laying eggs in critical tissues. The periodical cicada lays eggs (oviposits) in one-year-old twigs of fruit and ornamental trees, splitting the wood so severely that the entire twig often dies. The dead twig results in damage called “flagging.” These twigs eventually fall to the ground and as soon as the young nymphs hatch, they drop to the soil and burrow in for further development.

Vectors of Disease

In addition to insects causing direct damage to plants through feeding activities, insects can also cause indirect damage by transmitting plant pathogens. Some of the most important insect vectors are sucking pests, which acquire plant pathogens from sick plants and transmit them to healthy plants as they feed. Examples of insect vectors and the pathogens they transmit include: smaller European elm bark beetle (and other bark beetles) that transmit the fungus causing Dutch elm disease; aster leafhopper, which transmits the phytoplasma-like organism causing aster yellows; aphids and cucumber beetles that transmit cucumber mosaic virus; and Western flower thrips (and other thrips) transmitting tomato spotted wilt virus.

Beneficial Insects

The vast majority of insects are either beneficial or harmless. Less than 2 percent of all insect species are considered pests. Insects must be studied carefully to distinguish the beneficial from harmful ones. Unfortunately, beneficial insects like predatory larvae of lady beetles are often mistaken for pests and destroyed.

Insects are beneficial in several ways:

1. Insects provide us with food and products, such as dyes, honey, silk, shellac and wax.

Insects aid in the production of fruits, seeds, vegetables and flowers by pollinating the blossoms. The most common fruits consumed by humans are at least partially pollinated by insects. Melons, squash and many other vegetables require insects to carry their pollen before fruit set. Insect-pollinated ornamental plants include chrysanthemums, irises, orchids and yuccas.

2. Insects destroy various weeds in the same way they harm crop plants.
3. Insects improve the physical condition of the soil and promote its fertility by burrowing through several soil layers. Dead bodies and insect frass release nutrients to the soil.
4. Insects provide a valuable service as scavengers and decomposers by breaking down animal, plant and waste matter. After all, it's a dirty job but someone's got to do it!
5. Perhaps most importantly, insects can be predatory or parasitic, feeding on many plant-feeding insects and maintaining pest populations below damaging levels.

Insects that feed on other insects can be classified into two groups: predators and parasitoids (parasites). Predators are insects (or other arthropods) that catch and devour other creatures (prey), usually killing and consuming them in a single meal. Predators are generally larger, stronger and faster than their prey. Examples of arthropod predators include spiders, predatory mites, centipedes, scorpions, lady beetles, lacewings, robber flies, dragonflies, damsel bugs, assassin bugs and larvae of syrphid flies. Parasitoids live as larvae within the bodies of other insects (hosts), consuming their innards but leaving vital organs intact. Thus, hosts remain alive while the immature parasitoid feeds and completes its development to the adult stage. Parasitoids are generally smaller and weaker than their hosts, particularly in the immature stage. Parasitoid species are largely wasps or flies, and include braconid wasps, ichneumonid wasps, trichogrammatid wasps and tachinid flies.

Chapter 9: PLANT DISEASES

Learning Objectives:

After completing this section, Master Gardener trainees will be able to:

- Know the differences between infectious and noninfectious diseases and what causes them.
- Understand the disease triangle and its significance in disease management and control.
- Know how to describe a disease and understand the difference between signs and symptoms.
- Be able to diagnose basic plant diseases and know how to manage them.

Chapter 9: Plant Diseases.....345

Introduction	345
The History of Plant Diseases	345
What is a Plant Disease?.....	346
The Disease Triangle	346
Host plant	346
Pathogen	347
Environment.....	347
The Disease Triangle in Action.....	347
Manipulate the host	347
Manipulate the pathogen	348
Manipulate the environment	348
Types of Plant Pathogens.....	349
Fungi.....	349
Bacteria	349
Viruses and viroids	350
Plant parasitic nematodes.....	350
Parasitic higher plants.....	350
Describing a Plant Disease	351
Environmental or Pathogen Problem?	351
Environmental Stress Problems.....	353
Selection of plant material	353
Proper planting	353
Proper plant maintenance	353
Site disturbance	354
Climate	354
Fertility and soil pH.....	354
Chemical injury.....	354
Diagnosis of Plant Diseases.....	354
Define the problem.....	354
Diagnose the problem.....	358
Management of plant diseases	358
Conclusion.....	359

Introduction

Most U.S. Citizens live in a place where there is an abundant supply of affordable food. In much of the world, the food shortages are common and famines occasionally occur. Crops may fail when they are parasitized by microorganisms and plant disease develops. The scientists that study the plant diseases are called plant pathologists.

Plant diseases are caused by environmental factors and living microorganisms including fungi, bacteria, viruses and nematodes. Much of our world history has been shaped by the search for food. Even in today's modern world, our food supply is vulnerable and plant breeders struggle to stay ahead of the changing strains of pathogens threatening our crops. The goal of this chapter is to provide an overview of the important principles of plant pathology, the study of plant diseases.

A Brief History of Plant Diseases

There are many examples of how plant diseases have influenced human culture and civilization. Plant diseases are often referred to in the Bible where people believed they were being punished by God. An excerpt from Deuteronomy (28:22) reads "scorching heat and drought, with blight and mildew." Another excerpt from Haggai (2:17) states "I struck all the work of your hands with blight, mildew and hail..." The Hebrew people

at the time feared plant diseases and it is likely that fear of punishment influenced the development of early societies.

The most significant disease that has impacted our world is the Irish potato famine. Irish farmers of the 1800s relied on potatoes as their primary source of food. In 1845, a new disease called late blight of potato arrived in the country. It is likely that the pathogen *Phytophthora infestans* was brought from America to Ireland in the cargo holds of ships. Rainy weather was highly conducive to disease development, and virtually the entire crop was lost. During the next few years, the blight continued to destroy the potato crop, which led to the death of 1 million people in Ireland. It is estimated that another 1 million left Ireland and immigrated to the U.S.

In more recent times, two diseases of forest trees in the U.S. have led to great losses. Chestnut blight arrived around 1900 and has virtually destroyed all of the American chestnut trees. Dutch elm disease first arrived in the U.S. in 1928 and most American elm trees in the east were killed in the 1950s and 1960s. Dutch elm disease continues to be a problem today as additional elms become infected and die.

These examples are atypical of most plant diseases because the level of damage is very high. Most plant diseases vary in their level of damage each year, since they are strongly influenced by weather patterns. However, with increased movement of plant products, plants have never been more at risk than they are today. We can only hope that new epidemics can be avoided in the future.

What is a Plant Disease?

Plant diseases are relatively common and most plants are troubled by at least a few problems. Plant pathologists define plant disease as any abnormal growth of a plant that interferes with its normal appearance, value or function. Plant diseases can be caused by infectious organisms or may have non-infectious causes.

Infectious plant diseases are caused by living organisms including fungi, bacteria, nematodes, viruses and parasitic plants. These diseases can be transmitted plant to plant. A non-infectious disease occurs when there is a problem in the environment where the plant is grown. Although multi-

ple plants may be affected, the problem does not spread from plant to plant. Examples of non-infectious diseases are heat, cold, salt, nutritional imbalance, and improper watering.

The Disease Triangle

There are three primary factors that determine if disease will develop. These requirements are the presence of a susceptible host, a virulent pathogen, and a favorable environment. Each of these factors represents one of the sides of the Disease Triangle (Figure 9.1). If one of the requirements is missing, the triangle will collapse and disease will not develop.

Host plant

The first factor in the disease triangle is the presence of a susceptible host plant. The age or developmental stage of the plant may influence susceptibility. For some diseases, only the seedling stages are attacked. For others, the plants may be susceptible in all stages or other developmental stages such as reproduction.

Host plants in good health are less likely to be attacked by plant pathogens. For many diseases, nutritional imbalances or stress will make disease more likely to develop. For instance, plants that have received heavy nitrogen applications may be more likely to develop foliar diseases.

Plant breeders have developed plants less likely to become infected and develop disease. These plants are called tolerant or resistant to a

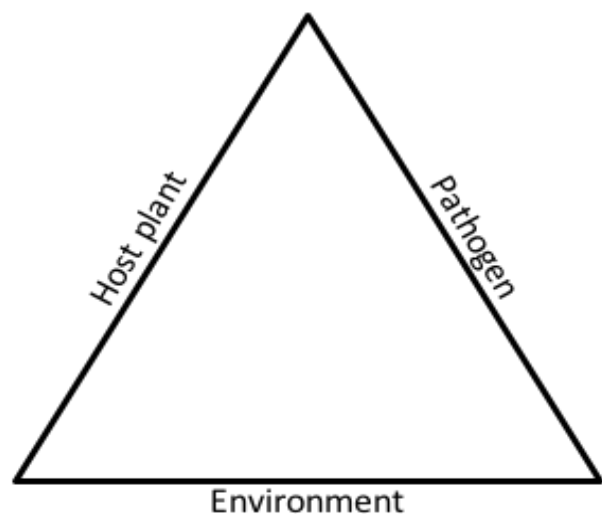

Figure 9.1 The plant disease triangle.

certain disease problem. Plants vary in their susceptibility and even resistant plants may show a low level of a disease.

Pathogen

The second requirement of the plant disease triangle is the presence of a pathogen that can cause disease. If there is no pathogen present, disease will not develop. Many efforts can be taken to exclude plant pathogens. On a large scale, quarantine programs are in place to prevent the introduction of high-risk plant pathogens into new areas. Treating seed may be one way to exclude certain types of plant pathogens. When plant material is removed and destroyed, it can reduce the pathogen level and lower the risk of secondary infections.

When researching plant diseases and attempting to diagnose a problem, it is important to confirm the pathogen does occur in the area. Diseases common in the Mid-Atlantic region of the U.S. may not be present or may be rare in the Great Plains region. Pathogens may also vary in their virulence (aggressiveness) and different strains or races of the same organism may not cause the same level of disease or affect the same hosts. An example of this is Southern bacterial wilt, caused by *Ralstonia solanacearum*. Race 1 is occasionally found in Oklahoma, but *R. solanacearum* race 3, biovar 2 is not found in the U.S. and is highly regulated.

Environment

The final requirement of the plant disease triangle is a conducive environment. The environmental conditions must be suitable for the pathogen to infect the plant and cause disease. Temperature and moisture (free moisture or humidity) must be at proper levels to allow the pathogen to infect. In general, the optimum temperature range for infection of many plant pathogens is between 50 F and 80 F.

It is possible to manipulate the environment and reduce the risk of plant disease. This can be done by altering planting dates, careful selection of irrigation methods, timing of irrigation, improving drainage and more.

Later, there will be a thorough discussion of management of plant diseases. The key goal of disease management is to manipulate the disease triangle so at least one of the three sides is dis-

rupted. As a result, plant diseases are less likely to occur or the effects will be minimized. Since plant pathogens can adapt, it is recommended to use multiple, integrated approaches for an effective disease management program.

The Disease Triangle in Action

Many home gardeners desire to grow vegetables such as tomatoes and peppers. An example will be given of a disease problem that occurs in Oklahoma and how the disease triangle can be manipulated to reduce the damage caused by this disease.

Early blight of tomato is caused by the fungus *Alternaria solani*. This disease is found in Oklahoma at some level each year. Home gardeners that have had early blight in previous seasons are at greater risk of having a problem than growers that have never had the disease in their garden.

Early blight appears early in the growing season, usually before the tomatoes have ripened. The symptoms begin as small, water-soaked spots on the leaves, which then become brown. As the disease progresses, the lesions will enlarge and take on a target spot or bull's-eye appearance. Several lesions may coalesce (join) so large areas are blighted. The entire plant may become discolored and wilted. The tomato plants will often defoliate and the delicate tomato fruits can develop sunscald injury.

In areas where early blight has been a problem, there are many actions a home gardener can use to manipulate the disease triangle to reduce the level of disease.

Manipulate the host

If the disease has been present in previous seasons, growers should select tomato varieties that are tolerant or resistant to early blight. If a variety has disease resistance, the seed companies will generally indicate this on the seed packet or transplant. It may be necessary to spend some time researching varieties in seed catalogs, online or in books before selecting one. For early blight, the seed packet may be labeled 'A', 'AB' or 'EB' to indicate resistance to early blight. Other resistance abbreviations that may be found on seed packets are 'V' for Verticillium wilt, 'N' for root-knot nematodes, 'F' for Fusarium wilt, 'T' for Tobacco Mosaic

Virus and more. If a grower has had a problem with a disease in the past, selecting a resistant variety is recommended.

Other ways to manipulate the host are to destroy diseased plant debris and use crop rotation. The spores of the fungus may survive the winter on crop debris or in the associated soil. Any diseased plant material should be removed and discarded in the trash. Do not compost diseased material. Most home compost areas do not reach the necessary temperatures and times needed to break down pathogen inoculum (infectious propagules).

Once crop debris has been removed, the soil may still be infested with the pathogen. One way to avoid or reduce the level of disease is to move tomatoes out of the infested soil to another area of the garden. Wait a few years before planting a susceptible host in that area, and the level of inoculum will have been reduced by microorganisms and environmental conditions. It should be noted that many diseases affecting tomato will also damage related plants in the Solanaceae family. These include peppers, eggplants and potatoes. It is best to avoid planting any Solanaceous plants in the soil where a disease such as early blight has been a problem in the past.

Manipulate the pathogen

The second leg of the plant disease triangle involves the pathogen. It is best to avoid introducing a pathogen into the garden, a technique known as exclusion. If selecting plants from a garden center, confirm they are healthy plants. Take a moment to examine the entire plant, including the roots. Plants with leaf spots, yellowing leaves or brown roots should be avoided. It is also helpful to maintain plants in a holding area for a few weeks to ensure disease does not develop. Only healthy plants should be installed in the landscape or garden.

If a disease develops, the plant should be removed or treated with a chemical, such as a fungicide. Many gardeners will wait until a problem is out of control before attempting to treat the problem. By this time, the disease may have spread to other areas and plants in the garden. It is best to act quickly. Later, will be a discussion about how to identify and treat different types of diseases. This will be important for selecting an appropriate fungicide for the problem or deciding if plant removal is the best control strategy.

Manipulate the environment

There are many ways to manipulate the environment to reduce the level of plant disease. Proper watering techniques are a key aspect in limiting plant diseases. Rainfall cannot be controlled, but the irrigation water provided to plants can be manipulated.

Many pathogens require several hours of free moisture for spores to germinate. If watering plants in early or mid-day, the periods of leaf wetness will be reduced. This will reduce the chance that a spore can germinate and initiate disease. It is best to avoid watering in late afternoon or evening. Plant surfaces may remain wet for many hours and the likelihood of disease development is increased.

The type of irrigation employed can greatly influence disease levels. Growers using overhead irrigation are more likely to have disease problems than those using drip or soaker hose irrigation. Overhead irrigation wets the foliage and can cause splash dispersal of foliar pathogens. The roots are the primary plant part that absorbs water. Very little water is absorbed through the leaves. By watering the foliage, a humid and moist environment is created that is highly conducive for disease development. When possible, water the soil below the foliage and avoid wetting the canopy. If overhead irrigation must be used, water in early or mid-day when the foliage will dry more quickly.

Plants should be properly spaced to allow for adequate air circulation. When plants are overcrowded, the relative humidity and free moisture may remain high for long periods. These conditions will favor development of disease. Be sure to read seed packets and plant tags for proper spacing recommendations. When necessary, thin plants to avoid overcrowding and increase air circulation through the canopy.

Growers can manipulate the environment by altering planting date of a crop. In some cases, this allows us to escape the most favorable periods for disease development. In Oklahoma, tomatoes are generally planted in early to mid-spring. Growers that plant later are less likely to have problems with early blight than growers that plant early. It is more likely weather periods favorable for disease happen in early spring, so setting out transplants later can help growers avoid the most optimum period for infection. During these favorable weather periods, use of a foliar protectant fungicide may be helpful to reduce the likelihood of disease development.

Another aspect of manipulating the environment is through sanitation. In areas where disease has been a problem, crop debris (fallen leaves, rotted fruits) should be discarded in the trash. By removing the infested debris from the site, the number of infectious propagules is reduced. Diseased plant material should not be composted.

Types of Plant Pathogens

There are five primary categories of plant pathogens. They include fungi, bacteria, viruses and viroids, plant parasitic nematodes and parasitic plants.

Fungi

Most plant diseases are caused by fungi, which include molds, yeasts and mushrooms. Fungi grow as a fine, thread-like strand called a hypha (plural hyphae). When hyphae are in mass, they are called a mycelium (plural mycelia) or the body of the fungus. Most of us have observed fungi growing on old produce or bread. Most fungi are natural decomposers, but some fungi can attack plants during the growing process and are called plant pathogens.

All plants have at least one fungal pathogen and most plants are affected by many. Some fungi can infect many different hosts in different plant families and are considered to have a wide host range. Others are more restricted and have a narrow host range. A narrow host range may be limited to one species or one family of plants. It is helpful to determine if the pathogen has a narrow or wide host range when considering replanting and rotational options.

In general, most fungi reproduce with infectious propagules. Depending on the type of fungus, different types of propagules are produced which may be called conidia, ascospores, sporangia, oospores, sclerotia and more. Fungal propagules are similar to seeds of plants. They are microscopic and serve as the primary means of spread for most fungi. When the propagules land on a suitable host, they will germinate and attempt to infect a host.

Fungi are spread in many ways. Short distance movement is often by splash dispersal or movement of spores on wind currents. Longer distance spread may be through contaminated plant material or equipment or transportation by insects.

Fungi are effective plant pathogens because many fungi can directly penetrate a plant and force themselves through the surface of the host. Fungi can also enter passively through natural openings or wounds.

Fungi do not have mouths and therefore must find another way to “eat.” To gain nutrition, fungi release chemicals into their environment that dissolve plant cell walls or wax layers. As plant cells die, they become leaky, which is attractive to many types of microorganisms. Secondary decay rapidly begins, so it can be difficult to separate a plant pathogen from these secondary invaders. This is one factor that makes diagnosis of a pathogen problem difficult.

Most fungi can survive during unfavorable periods in a resting spore or structure. This may be during the winter, dry weather periods or in the absence of a suitable host. The resting spore or structure is generally thick-walled and durable to better withstand environmental extremes.

Bacteria

Infections caused by bacteria are very common in humans and other animals. Plants are also affected by bacterial diseases, but the species causing disease in plants will not generally affect healthy humans. Plant pathogenic bacteria are single celled and generally bear one or more flagella that enable them to move small distances in liquid.

Bacteria are simple organisms and “feed” by absorbing nutrients. They may release toxins to break down plant cells, so bacterial diseases may have a greasy, water soaked appearance around a lesion site. Toxins near the infection site may cause chlorophyll (green plant pigment) to disintegrate, so many bacterial lesions will have a yellow halo around the dead tissue. As bacteria enlarge, they will reproduce simply by dividing in half (binary fission). In the plant disease process, bacteria can reproduce rapidly with favorable conditions.

Bacteria generally enter plants through natural openings or wounds. They may also enter with the help of insect vectors, infested soil or propagation materials, or contaminated tools.

There are three groups of specialized bacteria that can cause plant disease. These organisms differ than normal bacteria because they can only live in the water- and nutrient-conducting cells (xylem and phloem) of the host plant. Typical bacteria

can be cultured on media in Petri dishes, but it is difficult or impossible to culture these specialized bacteria on artificial media.

Two groups of these specialized bacteria are called phytoplasmas and spiroplasmas. Phytoplasmas do not have a defined shape, while spiroplasmas take on a spiral shape, as the name implies. These organisms differ from regular bacteria because they do not have a cell wall or flagella. Phytoplasmas and spiroplasmas live in the phloem of plants and are transmitted by insects that feed on these cells, such as leaf hoppers and psyllids. They interfere with normal movement of nutrients and sugars in the plants to cause abnormal symptoms. They generally cause distortion or the flower parts remain green.

The third group of specialized bacteria is referred to as fastidious. These bacteria are extremely difficult to culture in the laboratory and may only be found in specialized plant cells. One example of fastidious bacteria is *Xylella fastidiosa*, the cause of Pierce's disease of grape and bacterial leaf scorch of shade trees.

Viruses and viroids

Viruses and viroids are the smallest plant pathogens and can only be seen with an electron microscope. They may be spherical or rod-shaped, depending on the type of virus or viroid. Viruses consist only of a piece of nucleic acid (genetic material) and a protein coat that protects them. Viroids are nucleic acid only. Since viruses and viroids are so simple, they cannot replicate without a host. Many viruses are moved with the help of an insect vector. In some cases, the viruses can replicate in both the plant host and the insect host.

For a virus or viroid to infect, it must enter the plant through a wound, natural opening or with the help of an insect. Common insects that can transmit viruses are aphids, thrips, leafhoppers, and white flies. Once a plant becomes infected with a virus, it cannot be cured. In some cases where detection is early, an infected branch can be removed before it has spread to the other branches.

Other than insects, viruses can be spread by grafting and infected propagation material. They may be transmitted by contaminated tools or equipment. Some viruses can be transmitted by pollen or seed. They may survive without a host plant through an alternate host (such as a weed),

and for brief periods, in infested plant debris and in insects.

Plant parasitic nematodes

Nematodes are common in nature and most nematodes are not plant parasitic. The majority of nematodes are free-living or saprophytic. These nematodes feed on decaying organic matter, bacteria or fungal spores. All nematodes are non-segmented roundworms and most are microscopic. Plant pathogenic nematodes differ from other nematodes because they bear a stylet (sharp, needle-like structure) that penetrates plant cells. The nematodes use the stylet to absorb nutrients from the plant cells and may excrete enzymes through the stylet.

Most plant parasitic nematodes live in the soil, but a few feed on aerial plant parts. Some types of nematodes can cause root galls or swellings. Others may cause root stunting or stubby proliferation of roots. Most nematodes can survive in the soil on decaying plant debris or on weed hosts in the absence of a crop.

Nematodes reproduce by eggs and they generally molt four times before they become adults. Although they can move small distances in soil, most nematodes are spread with help. The pine wood nematodes that cause pine wilt are moved with the help of an insect vector and in infested pine wood. Soil-borne nematodes are generally moved when they are carried on equipment contaminated with infested soil. Rhizomes, tubers or bulbs may be contaminated and could be a potential source of plant parasitic nematodes.

During unfavorable periods, nematodes will migrate deeper into soil. When sampling a field for a suspected nematode problem, it is best to sample near harvest time. Since most soil contains nematodes, plant pathologists have developed thresholds to determine if visible or economic damage is likely at the population level. It is always helpful to sample from an unaffected area of the same field as a healthy "check" sample.

Parasitic higher plants

A parasitic plant is a plant that obtains some or all of its nutrition from another plant. Parasitic plants produce specialized structures (haustoria) that attach and enter their host plants. These structures withdraw water and nutrients from the host. Holoparasites are parasitic plants that obtain all

of their nutrition from another plant. These include dodder and broomrape. A hemiparasite is a parasitic plant that obtains some of its nutrition from another plant. Most hemiparasites are capable of some photosynthesis, but obtain water and nutrients from the host plant. Hemiparasites include mistletoe and Indian paintbrush.

Three types of parasitic plants often found in Oklahoma are mistletoe, Indian paintbrush and dodder. Mistletoe is so common that it is the state floral emblem of Oklahoma. The mistletoe in Oklahoma is actually leafy mistletoe (*Phoradendron* spp.). In other parts of the world, other types of mistletoe such as dwarf mistletoe (*Arceuthobium* spp.) may occur. Leafy mistletoes are hemiparasites. They are green, which indicates they have chlorophyll. Mistletoes are capable of photosynthesis, so they produce some of their own food. Mistletoe is found in many types of trees including ash, maple, elm and oak and it is most common on old or stressed trees. The host plant will lose vigor, but the leafy mistletoe in Oklahoma does not usually kill the tree. In most cases, other pathogens, insects or environmental stress factors are involved and contribute to the ultimate death of the tree. The best control for mistletoe is to remove infested branches by pruning.

Dodder (*Cuscuta* spp.) is often seen on roadsides and occasionally in fields in Oklahoma. The plant produces a mat of yellow vines and has been described as spaghetti-like. Dodder will cover the host plant and eventually kill it.

The Indian paintbrush (*Castilleja*) is a beautiful and common wildflower. This plant is a hemi-root parasite. This means that although it can live by itself, it performs much better when it parasitizes another plant. The Indian paintbrush will insert haustoria into the root of a host plant to obtain nutrients and water.

Parasitic plants are higher plants and they reproduce by seeds. Mistletoe is especially desirable around Christmastime, since the plants produce white berries (containing seeds) at this time of year and mistletoe is used as a holiday decoration. The seeds are spread by animals (especially birds) and wind. Occasionally, the seeds of dodder have been found in crop seed such as alfalfa and can be distributed when new fields are planted with the contaminated seed.

Describing a Plant Disease

Plant pathologists use a specialized vocabulary to describe symptoms and signs of plant diseases. This terminology allows concise description on how the plant varies from its normal appearance. In a later section, these terms will be used to categorize common types of plant disease, so it is important to understand the vocabulary.

Plants affected by a disease will show both symptoms and signs. A symptom is a physical expression of the disease. It is how the plant alters its normal growth in response to a disease problem. Some symptoms may be minor, while others are dramatic. The list of symptoms in Table 9.1 is not complete, but the most common symptoms are included.

A sign is when the pathogen itself or evidence of the pathogen is visible. Most signs appear when the plant is in advanced stages of the disease. The pathogen itself is observed and most signs are produced by fungi. The most common signs are described in Table 9.2.

Environmental or Pathogen Problem?

Problems caused by environmental factors are much more common than plant pathogens, so it is important to recognize how these problems differ. If plants are grown with improper environmental conditions, it will often weaken plants, making them more likely to be attacked by a pathogen.

Growers should first familiarize themselves with the normal growth habit of a host plant. It is also helpful to learn about the most common diseases that affect the host plant, so symptoms induced by these pathogens can be scouted more easily. When scouting a plant, the entire plant should be examined when possible. It is helpful to excavate plants to examine the roots and lower crown areas.

Problems caused by environmental factors will generally affect more than one type of plant. It is important to observe neighboring plants and determine if these plants are affected. Most plant pathogens have a narrow host range, so if non-related nearby plants exhibit unusual symptoms, it may suggest an environmental factor.

The pattern of damage may be important. Some diseases are found on young leaves, while

Table 9.1. Common symptoms of plant diseases.

<i>Symptom</i>	<i>Description</i>	<i>Cause</i>	<i>Example</i>
Anthracnose	Irregular patches of dead tissue, which may follow the veins	Fungi	Sycamore anthracnose
Blight	Rapid death of tissue. Flowers, twigs or foliage may be affected	Bacteria, fungi, abiotic	Fire blight of apple
Canker	Dying or dead sunken, swollen or discolored areas on a stem or branch	Bacteria, fungi	Leucostoma canker of peach
Chlorosis	Yellowing of normally green tissue	All types	Iron chlorosis
Distortion	Tissue growth is abnormal so that plant structures appear different than normal	Viruses, bacteria, fungi, abiotic	Peach leaf curl
Gall	Excessive tissue growth that results in abnormal swellings on leaves, stems or roots	Bacteria, nematodes, fungi, abiotic	Crown gall
Mosaic and Mottle	Intermingling of yellow and green, usually observed on the leaves	Viruses, Bacteria	Cucumber mosaic virus
Necrosis	Death of tissue (not decay)	All types	Impatiens necrotic spot virus
Rot	Decay of tissue. May be dry rot (firm and dry) or soft rot (softening, tissue breakdown)	All types	Soft rot of potatoes
Scab	Crusty appearance, often appears superficial	Fungi	Pecan scab
Spot	Lesion, may be circular or angular	All types	Black spot of rose
Wilt	Loss of rigidity of plant or parts, drooping plant parts	All types	Dutch elm disease

Table 9.2. Common signs of plant diseases.

<i>Sign</i>	<i>Description</i>	<i>Cause</i>	<i>Example</i>
Bracket or conk	Fruiting structure observed on trees. Usually has a shelf-like appearance	Fungi	Ganoderma butt rot
Fruiting bodies	Formed on plant surfaces, usually within lesions or cankers. Tiny structures, often brown or black that will release spores with favorable conditions.	Fungi	Phyllosticta leaf spot of ornamentals
Mildew	Whitish-gray mycelial growth on plant surfaces	Fungi	Powdery mildew of ornamentals
Mycelia	Presence of masses of fungal hyphae on plant parts or the soil surface	Fungi	Southern blight of vegetables
Ooze (flux)	Fluid that exudes from some diseased plants, usually contains bacteria and plant substances	Bacteria	Wetwood of shade trees
Rhizomorphs	Strands of a fungus are produced by some wood decay organisms under the bark of trees and are usually black	Fungi	Armillaria root rot
Rust	Lesions that exude masses of spores, usually appear orange in color, but can be black or white.	Fungi	White rust of spinach

others attack the older leaves first. Many types of environmental factors will cause damage that does not spread to new growth. In many cases, plants damaged by abiotic factors may “grow out” of the problem, whereas plant pathogen problems will usually become worse. Plants affected by pathogens generally have a scattered appearance, with plants in varying stages of decline. Plants injured by environmental factors may show similar levels of damage or a gradual reduction in symptoms when moving away from the origin of the problem.

Weather is important in the development of plant diseases. Most plant pathogens are active during moderate temperatures and many require periods of leaf wetness. If the temperatures are extremely high or low or if the environment is dry, this may suggest an environmental problem.

Plant pathogen problems take time to develop. It would be unusual for the symptoms to appear overnight. Usually, a disease caused by a pathogen will progress and the plant will decline with time. In contrast, problems caused by abiotic factors may develop quite quickly.

Environmental Stress Problems

Most of the problems observed on plants are caused by one or more environmental stress factors. It is estimated 50 to 85 percent of plant problems are due to environmental or cultural problems. These problems include chemical injury, improper fertility or pH, soil moisture issues and site disturbance. In many cases, there may not be a treatment for environmental problems for established plants. It is best to ensure the plants have a proper start, then maintain health.

Selection of plant material

Growers should select plants well adapted to the area and proper for the site. Growers should identify the light availability, soil characteristics (pH, moisture, soil type) and temperature extremes in a given location in the landscape. Only plants appropriate for the site should be installed. When plants are poorly selected for a site, their performance and vigor may be low. Plants in improper sites are more likely to be attacked by plant pathogens and insects.

Proper planting

Growers should take time to properly place plants in the site to avoid future problems. Plants with tight or girdling roots will show reduced vigor. In some cases, portions of the plant or the entire plant may die if a problem is not remedied at planting. Plants should be placed in the soil and not be planted too shallow or deep.

Plants that lack in proper nutrients generally show symptoms of yellowing and may look similar to damage from a plant pathogen. When excess nutrients are applied, the foliage may burn or have spots. It is best to apply fertilizer based on the results of a soil fertility test.

Proper plant maintenance

After planting, it is essential to irrigate plants until they become established. For many trees and shrubs, it takes two or more years to become fully established. Even established trees will require watering during periods of drought. Plants not receiving adequate water will suffer. Common symptoms of inadequate watering include marginal leaf browning (scorch), wilting and poor vigor.

It is essential to ensure plants have good drainage and are not being overwatered. Plants in heavy soils with high clay content are more likely to suffer from overwatering than plants in sandy soils. Saturated soils will cause stress and damage to the roots. Anaerobic (without oxygen) soils sometimes have a foul odor. Symptoms of overwatering are similar to those of inadequate watering. Plants grown in heavy and wet soils are more likely to be attacked by some plant pathogens than plants grown in soils with proper drainage and moisture levels.

Mulching is used as a method to prevent the loss of moisture from the soil. It is also used to avoid competition from plants and weeds under trees and shrubs. Mulching is helpful if it is done properly. Mulch should be applied to a depth of 2 to 4 inches and should not be piled around the trunk or stem of plants. If mulch is deeper than 4 inches, it may prevent water from penetrating the mulch and reaching the soil, thus reducing the amount of water in the soil. Thick mulch layers may result in low soil oxygen levels. Plants with excessive mulch are more likely to be attacked by crown and root rot pathogens.

Site disturbance

It is not uncommon for plants to show poor health if the soil around them has been disturbed. This can be the result of compaction, where vehicular or foot traffic occurs over the root zone of the plant. It may occur when there is digging near the root zone or if soil is added over the root zone of the plant. Most roots are found in the upper 6 to 12 inches of the soil. Disturbing the soil around plants changes the availability of oxygen and water and can negatively affect plants.

Climate

Oklahoma is a state where severe and extreme weather is common. Our temperatures range from extremely high to extremely low. Most years, there are drought conditions, although floods do occasionally occur. Plants in Oklahoma must be able to withstand weather extremes. For annuals, it is important to plant at the proper time to avoid high or low temperatures. For example, high temperatures may cause spinach to bolt (flower) rather than produce leaves. Low temperatures can damage warm season crops such as tomatoes.

When installing trees and shrubs, only plants suited for our climatic zone should be selected. Based on the USDA Hardiness Map, Oklahoma is in zones 6a to 8a, which indicates the average annual extreme minimum cold temperatures. Most of central Oklahoma falls in zone 7A, indicating the minimum average cold temperatures are 0 F to 5 F. Plants not suited for the cold temperature zone will perform poorly or be killed by freezes.

It is important to determine the water requirements of a plant and to properly irrigate to meet the needs. Due to recent droughts, many plants have declined or died due to inadequate soil moisture. Prior to installing plant material, growers should consider the water needs and only plant materials appropriate to the site.

Fertility and soil pH

Plants that receive improper nutrition will perform poorly. Under-fertilized plants are generally stunted and chlorotic. Plants that receive excess nutrients may suffer from burning of the leaves or roots. Soil amendments should be applied based on the results of a soil fertility test.

The pH of soil strongly influences the ability of plants to recover nutrients from the soil. Most plants perform well in soils with pH levels of 6.0

to 7.0. Some plants, such as azaleas and blueberries, are better adapted to lower soil pH levels (acid soils) of 5.5 and will show poor vigor in soils above pH 6.5. Many soils in Oklahoma have pH levels greater than 7.0. These alkaline soils can result in a problem known as iron chlorosis on many shrubs and trees. At pH levels greater than 7.0, nutrients, including iron, are tightly bound to soil particles. Iron is an essential plant nutrient and plants suffering from iron chlorosis generally have light green-yellow leaves with green veins. Plants that do not tolerate high pH soils should not be planted in these sites and will show reduced vigor. In Oklahoma, this problem is commonly observed on pin oak and red maple trees. The soil should be tested prior to planting to ensure appropriate plants are selected for the site.

Chemical injury

Improper use of chemicals is an increasing problem to plants. When plants are exposed to certain types of chemicals, they may show unusual symptoms including chlorosis, necrosis, distortion, stunting or death. Plants vary in their sensitivity to chemicals and not all chemicals will affect every type of plant. If chemical injury is the cause of the problem, several different types of plants often will be affected. It is difficult to test for chemicals, since many of them degrade quickly and it requires expensive and specialized equipment. Most problems caused by chemical injury are diagnosed with a complete history of the problem and by ruling out other diseases. Plants damaged by chemical injury may recover, but should be treated carefully to reduce stress during the recovery period.

Diagnosis of Plant Diseases

Diagnosing a plant disease can be difficult since many factors can cause similar symptoms on a plant. Environmental conditions strongly influence plant growth and overall health. It is important to obtain a complete history of the problem and to collect a good sample for the problem to be properly diagnosed.

Define the Problem

The key below will lead to the likely cause of problems with plants. Many plants are affected by

more than one problem, so try to concentrate on the primary problem observed. There is a brief description of the problem, followed by a few disease examples.

- Identify the primary plant part that is affected.
- Leaves Section II
- Stem or trunk Section III
- Roots Section IV
- Flowers or fruits Section V
- Whole plant Section VI

Section II. Problems with the leaves

a. Spots on the leaves

- i. Fungi are most commonly responsible for spots on the leaves. Most fungal leaf spots occur in the spring and fall when temperatures are moderate and free moisture is present. Leaf spots are somewhat round in shape and may have an uneven margin. The spots may be lighter in the center with a darker border. Using a magnifying glass, small fruiting structures that are roughly the size of grains of black pepper may be observed.
 1. Tomato-Early blight or Septoria leaf spot
 2. Photinia-entomosporium leaf spot
 3. Rose-Black Spot
 4. Oak-Tubakia leaf spot
- ii. Bacterial leaf spots may have a more angular appearance and are often bordered by a watery margin or yellow-halo. The center of the lesions may appear brown or black.
 1. Pepper-bacterial spot or speck
 2. Stone fruits-bacterial spot
 3. Geranium-Bacterial blight
 4. Grape-Pierce's disease
- iii. Viruses can cause leaf spots, but they are often accompanied by other symptoms. Leaf distortion, stunted or unusual flowering may also be present.
 1. Bedding plants and vegetable transplants-Impatiens Necrotic Spot Virus
 2. Hosta-Hosta Virus X
- iv. Rust leaf spot diseases may have orange, black or white eruptions in the center of the spot. It may transferred to a finger or clean tissue.
 1. Cedar-apple rust-apples
 2. Hollyhock rust-Hollyhock

3. Rose rust-roses
4. Leaf rust-wheat
- v. Stippling (tiny white spots) on the leaves.
 1. Spider mites
 2. Air pollution
 3. Freeze damage
- vi. Leaves with spots with a sharp, distinct margin. No fruiting structures are visible within the lesions. Problem may occur on both young and old leaves.
 1. Chemical injury

b. Leaves yellowing or discolored

- i. Overall, general yellowing
 1. Possible root problem; confirm roots are normal and healthy
 2. Possible nutrient deficiency; nitrogen deficiency would be more common on older leaves but other nutrients may also be involved.
 3. Insufficient light
- ii. Leaves yellow, but veins remain green
 1. Possible root problem; confirm roots are normal and healthy.
 2. Iron chlorosis; soil test recommended to determine soil pH.
- iii. Leaves green, but veins yellow
 1. Viruses
 2. Chemical injury
- iv. Leaves mottled or have a mosaic pattern or unusual line patterns on the leaves.
 1. Viruses
 2. Phytoplasmas
- v. Purplish appearance to leaves
 1. Nutritional problem
 2. Viruses
 3. Phytoplasmas
 4. Cold temperature injury

c. Leaves with gray, white or black patches

- i. White or gray, powdery coating on the surface of the leaves, especially upper leaf surface.
 1. Powdery mildew
- ii. White or gray coating on the lower surface of the leaves. Yellow areas may be present on upper leaf surface.
 1. Downy mildew
- iii. Black discoloration on the leaves, often can be removed by wiping. Leaves may be sticky or shiny.
 1. Sooty mold due to aphid or other insect infestation.

- d. *Leaf margins damaged or browning*
 - i. Sharp or distinct line separates green and brown areas. Leaf scorch is due to insufficient water flow to the leaves or excessive temperatures.
 - 1. Possible root damage is interfering with water flow to leaves
 - 2. Cold or high temperature injury
 - 3. Chemical injury
 - ii. Fuzzy or wavy line, often with different color patterns, separates green and brown areas.
 - 1. Bacterial leaf scorch
 - 1. Fungal leaf spot or blight
- e. *Leaves appear distorted or curled*
 - i. Fungal distortion-Fungi may cause distortion or curl, especially if leaves were infected during development
 - 1. Peach leaf curl
 - 2. Oak leaf blister
 - ii. Virus diseases
 - 1. Rose rosette virus
 - 2. Tobacco mosaic virus
 - iii. Chemical injury
- f. *Leaves are generally wilted*
 - i. Excess or inadequate soil moisture
 - ii. Improper light
 - iii. Improper planting
 - 1. Container plants may have roots that are pot bound
 - 2. Girdling roots
 - iv. Transplant shock
 - v. Fungal diseases – especially those that damage the roots or vascular tissues
 - vi. Bacterial diseases – most likely in roots or vascular tissues
 - vii. Viral diseases – some viruses cause wilt
 - viii. Nematode diseases – primarily soil-borne nematodes

Section III. Problem with the branches, stem or trunk

- a. *Dieback of the shoot tips*
 - i. Fungal causes
 - 1. Twig blight of willow
 - 2. Diplodia tip blight of pine
 - ii. Bacterial causes
 - 1. Fire blight
 - 2. Pseudomonas blight

- iii. Environmental causes
 - 1. Cold temperature or freeze injury
 - 2. Drought damage
- b. *Stem or trunk has one or more cracks or cankers (sunken, swollen or broken areas)*
 - i. Fungi may cause cankers and fruiting structures are occasionally present around canker sites. Often, brownish discoloration is visible in the wood associated with the cankered area.
 - 1. Biscogniauxia (Hypoxylon) canker of hardwood trees
 - 2. Botryosphaeria canker
 - ii. Bacteria frequently cause cankers, but no fruiting structures are observed. Ooze or exudates may be observed flowing from the canker sites. Internal discoloration of the wood is usually present.
 - 1. Fire blight disease
 - 2. Bacterial canker of stone fruits
 - 3. Wetwood
 - iii. Environmental causes
 - 1. Freezing temperatures may cause breaks, especially to thin barked or young trees
 - 2. Hail injury
 - 3. Lightning injury
- c. *One or more holes are present in branches, stem or trunk*
 - i. Insects such as borers. Holes are usually in a random pattern and may be most common on dead wood.
 - ii. Animals
 - 1. Squirrels or other rodents may damage trees
 - 2. Sapsuckers or woodpeckers may make a series of holes which appear in a horizontal line
- c. *Large swellings or overgrowths on the stems or branches*
 - i. Fungal causes
 - 1. Phomopsis galls on forsythia
 - 2. Black knot of plum and cherry
 - ii. Bacterial causes
 - 1. Crown gall of many broad leaf plants. Most common at the soil-line, but can be found on branches or roots as well.
 - 2. Honeylocust gall

- iii. Insect causes
 1. Stem or petiole galls may be induced by certain types of insects
 2. Unknown or natural causes
 3. Burls (often dome shaped)

- e. *Other damage to branches, stem or trunk*
 - i. Southwest injury is a problem that occurs on young or thin barked trees and is generally found on the south or west facing sides of the trunk
 - ii. Improper pruning, injury from lawn equipment, etc may cause unusual problems to branches, stem or trunk.

Section IV. Problem with the roots

- a. *Visible discoloration of roots or sparse roots*
 - i. Fungal pathogens cause root rot which may appear as dark discoloration to the roots, roots may disintegrate with gentle tugging, root system may be lacking or a poor odor may be present
 1. Phytophthora or Pythium root rot is primarily a problem in soggy or poorly drained soils. More common in low spots where water collects.
 2. Cotton root rot – mostly a problem in southern Oklahoma in counties that border the Red River.
 3. Rhizoctonia, Fusarium, Thielaviopsis root rots
 - ii. Bacterial pathogens may cause rot of the roots and lower stem. Tissues are usually soft, slimy and may have a bad odor.
 - iii. Soil-borne nematodes may cause root discoloration, lesions along roots, or a stubby appearance to the roots. Soil testing for nematodes is often necessary to confirm.
 - iv. Excessive or inadequate moisture
 - v. Girdled roots
- b. *Development of swellings or overgrowths*
 - i. Crown gall and related bacteria may cause the development of galls (swellings) on the roots. The lower stem or branches may show similar swellings. The interior is often white or tan and appears disorganized.
 - ii. Swellings or distortions on the roots of some plants may be caused by nematodes (usual-

ly root-knot nematode). The interior is usually white or beige.

- iii. On legumes, nitrogen-fixing nodules may be present which are beneficial to the plant. The interior is usually green or pink.

Section V. Problem with the flowers or fruits

- a. *Discoloration of flowers or fruits*
 - i. Fungal causes
 1. Botrytis flower blight
 - ii. Bacterial causes
 1. Fire blight
 - iii. Virus causes
 1. Tomato spotted wilt virus
 2. Rose mosaic virus
 - iv. Uneven ripening
 1. Green shoulders on tomato fruits (may be varietal or environmental)
 2. Sunscald
- b. *Spots on flowers or fruits*
 - i. Fungal causes
 1. Botrytis blight
 2. Scab diseases on apple or pecan
 3. Anthracnose on peppers
 - ii. Bacterial causes
 1. Bacterial spot of peppers and tomatoes
 2. Bacterial spot of peach
 3. Potato scab
 - iii. Virus causes
 1. Cucumber mosaic virus
 2. Flower breaking virus
 - iv. Environmental causes
 1. African violet spots from cold water
- c. *Flower blight or fruit rot*
 - i. Fungal causes
 1. Botrytis blight
 2. White mold
 - ii. Bacterial causes
 1. Soft rot of potatoes
 2. Bacterial rot of sweet potato
- d. *Flower or fruit deformation*
 - i. Fungal causes
 1. Peach leaf curl may affect fruits
 2. Apple scab may cause fruit deformation
 - ii. Viral causes
 - iii. Environmental causes
 1. Blossom end rot

Section VI. Whole plant problem

- a. *Death of seedlings (before or after emergence)*
 - i. Fungal causes
 - 1. Damping off or seedling blight
 - ii. Nematodes
 - iii. Environmental causes
 - 1. Excess or inadequate soil moisture
 - 2. Improper temperatures
 - 3. Low fertility
- b. *Stunted plants*
 - i. Improper planting
 - ii. Root problems (various causes)
 - iii. Virus diseases
 - iv. Nematodes
 - v. Chemical Injury
 - vi. Poor fertility, soil pH or other site problem

Diagnose the problem

Once a plant problem has been narrowed down to one or more possible causes, it is important to gather additional information about treatment of the plant and growing conditions. It is helpful to consult additional resources including fact sheets, crop guides, online resources and reference books to diagnose a plant disease problem. In some cases, laboratory analysis may be required.

The county Extension offices work with the Oklahoma State University Plant Disease and Insect Diagnostic Laboratory (PDIDL) for the identification of difficult plant and insect problems. A sample of the plant(s) showing the problem can be sent to the laboratory when the problem cannot be determined locally. It is important to include a representative sample. Often, entire plant samples are needed if the problem is in the lower stem or roots. Digital images that document the problem at the site are recommended whenever possible. Additional guidelines regarding sample collection and submission can be provided by the local Extension educator.

Management of plant diseases

Once the problem has been diagnosed, it is important to develop a management strategy to reduce or eliminate the plant disease problem. It is helpful to consult fact sheets, reference materials, online resources and reference books to learn as much about the particular disease as possible.

The best management plans include a mixture of methods that target cultural, genetic, biological and chemical approaches to reducing disease levels. This approach is known as integrated pest and disease management (IPM or IPDM). When growers rely on a single method, such as cultural control, the disease may not be reduced to acceptable levels. A mixture of approaches will often reduce disease levels and have a favorable environmental impact.

When preparing disease management strategies, it is helpful to review the information presented earlier about the plant disease triangle. If one or more sides of the triangle can be disrupted, the level of plant disease is often reduced.

In the section below, a short list of possible management options for a plant disease are listed. This list is not all inclusive, but is a good start when considering disease management plan.

Avoidance: A grower can avoid certain diseases by planting in a location that is a distance from other crops. Planting earlier or later may be helpful, since the most favorable time for disease can be avoided. Using disease-free planting materials or starting your own plants from seed may help avoid disease.

Exclusion: Plant quarantines are present for some disease problems to avoid introducing pathogens into certain areas. Growers should avoid introducing any plants suspect for disease into their planting sites. It can be helpful to isolate new plants and monitor growth for a period prior to installation. Maintaining good insect control will often reduce disease if carrier insects are involved in the disease cycle.

Eradication: At the first evidence of disease, the affected plant(s) or plant part(s) should be removed. The diseased material should be discarded in the trash. Once the disease becomes established in the area, eradication is difficult or impossible. Strategies including crop rotation, discarding diseased plant material, destroying alternate hosts and soil solarization may be helpful at reducing pathogen propagules.

Resistance: Many plants have genetic resistance to certain plant diseases. Although resistance is not immunity, the level of disease is well reduced in comparison to susceptible varieties. It is important to maintain proper plant care because resistance can be lost if plants are under stress due to improper environmental conditions.

Protection: It is difficult to cure a plant of disease. When conditions are favorable for disease development, it is helpful to treat a crop with an appropriate fungicide or bactericide to protect the plants. These products are often sprayed or dusted on to the surfaces of plants and help to prevent infection. For some diseases, control of carrier insects is helpful. Other treatments, such as barrier cloths, may also be useful.

Therapy: In some cases, removal of diseased plant parts can prevent spread of the disease to the remaining parts of the plant. In breeding programs, heat therapy is sometimes used to produce disease-free plants.

Conclusion

It is important to remember that most plants in our environment do not suffer from plant diseases. Maintaining plants in proper growing conditions is the best defense against attack by plant pathogens. Plant diseases are caused by many environmental factors and living microorganisms. When a plant disease is suspected, it is important to act quickly to identify the problem and to take action to reduce the level of disease following the guidelines of the plant disease triangle. The use of an integrated pest and disease management plan will help growers to successfully produce healthy plants in a sustainable manner.

Chapter 10: UNDERSTANDING PESTICIDES AND THEIR ALTERNATIVES

Learning Objectives:

After completing this section, Master Gardener trainees will be able to:

- Select the proper type of pesticide to control a particular pest.
- Explain the differences between preemergent, preplant and postemergent herbicides.
- Understand the differences between pesticide formulations.
- Be familiar with the pesticide label.
- Discuss proper application techniques.
- Explain how to properly clean pesticide equipment.
- Explain the differences between home garden and commercial pesticides.
- List several safety precautions to protect yourself and the environment when using pesticides.

Chapter 10: Understanding Pesticides and Their Alternatives360

Terminology	362
Pesticide Formulations	362
Surfactants, Additives or Adjuvants	363
The Pesticide Label.....	363
Application Equipment.....	365
Proper Applications.....	367
Calibrating Sprayers and Spray Patterns.....	368
Using Pesticides Safely.....	368
Pesticides and the Environment.....	368
Home Garden versus Commercial Pesticides.....	371
Pesticides and Organic Gardening.....	371
Pesticides and the Law	371
Pesticide Conversion Chart.....	372
Integrated Pest Management.....	372

The term pesticide refers to a chemical substance that will kill pests. Since it is physically impossible to eradicate an entire population of pests, pesticides are used as a tool to control or manage populations to a tolerance level. Due to government regulations, chemicals used to attract or repel pests and to regulate plant growth or function are also classed as pesticides.

Understanding the proper use of pesticides, both natural and synthetic, is imperative to their effectiveness and to applicator safety.

Terminology

The wording “insecticides and pesticides” is incorrect because insecticides are pesticides.

Types and functions of pesticides include the following:

<i>Insecticides</i>	control insects
<i>Miticides</i>	control mites
<i>Acaricides</i>	control mites, ticks and spiders
<i>Nematicides</i>	control nematodes
<i>Fungicides</i>	control fungi
<i>Bactericides</i>	control bacteria
<i>Herbicides</i>	control plants (herbicides kill plants, not just weeds)

<i>Rodenticides</i>	control rodents
<i>Avicides</i>	control birds
<i>Piscicides</i>	control fish
<i>Molluscicides</i>	control mollusks, such as slugs and snails
<i>Predacides</i>	control pest animals
<i>Repellents</i>	keep pests away
<i>Attractants</i>	lure pests
<i>Growth Regulators</i>	stop, speed up or otherwise change normal plant processes
<i>Desiccants, Defoliant</i> s	used to remove or kill leaves and stems
<i>Antitranspirants, Antidesiccants</i>	reduce water loss from plants; used to protect plants from winter damage, drought, wind burn and transplant shock. However, effectiveness is being questioned by recent research.

Pesticides can be grouped according to how they work. Many work in more than one way.

<i>Contact poisons:</i>	kill pests simply by touching them.
<i>Stomach poisons:</i>	kill when swallowed.
<i>Systemics:</i>	kill best by being taken into the blood of the animal or sap of the plant upon which the pest is feeding.
<i>Translocated herbicides:</i>	move from the point of initial application to circulate throughout the plant. The circulation of toxin ensures the kill of the entire plant.
<i>Fumigants:</i>	gasses which kill when they are inhaled or otherwise absorbed by pests.

Selective pesticides: kill only certain kinds of plants or animals, for example, 2,4-D used for lawn weed control, kills broadleaved plants but does not harm grass.

Nonselective pesticides: kill most plants or animals.

The following terms describe when to apply pesticides:

<i>Preemergence:</i>	use before plants emerge from soil
<i>Preplant:</i>	use before crop is planted by applying to the soil
<i>Postemergence:</i>	use after the crop or weeds have germinated

Terms which describe how to use pesticides:

<i>Band:</i>	application to a strip over or along each crop row
<i>Broadcast:</i>	uniform application to an entire, specific area by scattering
<i>Dip:</i>	immersion of a plant in a pesticide
<i>Directed:</i>	aiming the pesticide at a portion of a plant, animal or structure
<i>Drench:</i>	saturating the soil with a pesticide
<i>Foliar:</i>	application to the leaves of plants
<i>In-furrow:</i>	application to or in the furrow in which a plant is growing
<i>Sidedress:</i>	application along the side of a crop row
<i>Spot treatment:</i>	application of a pesticide to a small section or area of a crop

Pesticide Formulations

The formulation describes the physical state of a pesticide and determines how it will be applied. Pesticides are rarely applied full strength. The chemical in the pesticide formulation that actually kills the pest(s) is termed the active ingredient. The added chemical(s), those which make the product easy and safe to formulate or apply, are termed the inert ingredients. Common pesticide formulations follow.

<i>Emulsifiable concentrates</i> (EC or E)	The active ingredient is mixed with an oil base (often listed as petroleum derivatives) forming an emulsion, which is diluted with water for application. ECs are common in the home garden trade, being easy to mix and use. They can cause a minor surface bronzing of light-colored fruit. They should be protected from freezing temperatures which can break down the emulsifier.
<i>Solutions (S)</i>	These formulations are premixed, ready to use. They are often used in household pest products.
<i>Flowables (F or L)</i>	A flowable, or liquid, can be mixed with water to form a suspension in a spray tank.
<i>Aerosols (A)</i>	These are very low-concentrate solutions, usually applied as a fine spray or mist. They are generally sold in aerosol cans and are a very expensive source of pesticide.
<i>Dusts (D)</i>	Made by adding the active ingredients to a fine, inert powder or talc; generally used dry.
<i>Granules (G)</i>	Granular formulations are made by adding the active ingredient to coarse particles (granules) of inert material like fired clay particles.
<i>Wettable powders (WP or W)</i>	Wettable powder formulations are made by combining the active ingredient with a fine powder. They look like dusts, but they are made to mix with water. These formulations need continuous agitation to maintain a suspension and are thus difficult for home gardeners to use. When mixing a WP, first mix the measured quantity with a small amount of water, forming a slurry, (a paper cup with a popsicle stick makes a good disposable mixing container) then add it and the additional water to the spray tank. The spray tank must be frequently shaken to maintain the suspension.
<i>Soluble powders (SP)</i>	Made of an active ingredient in powder form; dissolves in water.
<i>Baits (B)</i>	A bait formulation is made by adding the active ingredient to an edible or attractive substance. Baits are often used to control slugs, snails, ground-dwelling insects and rodents.

Gardeners often attempt to compare a spray with a dust. It should be noted that dusts are a type of formulation, but sprays are not a formulation; they are one means of applying several different formulations such as wettable powders or emulsifiable concentrates that are mixed with water.

Surfactants, Additives or Adjuvants

When added to a pesticide, a surfactant reduces the surface tension between two unlike materials, such as a spray film and a solid surface. For example, by adding a surfactant to a sprayer, oil and water will mix and can be sprayed on plant surfaces. With increasing emphasis on safe application of pesticides, such factors as droplet size, spray pattern and pesticide drift have focused more attention on surfactants to give ideal coverage for pesticides.

Surfactants include activators; compatibility agents; deflocculators; detergents; dispersants; emulsifiers; foam and drift suppressants; and spreading, sticking and wetting agents. These materials are added to a spray mix to help keep the pesticide in suspension; improve cohesiveness and dispersion of the spray; and increase the wetting (or coverage) of the leaves, fruits and stems.

This section focuses on surfactants that act as spreading, sticking and wetting agents. They are most useful when spraying the hard-to-wet foliage of such plants as azalea, boxwood, camellia, carnation, conifer, euonymus, gardenia, gladiolus, holly, iris, narcissus, peony, rose and yew. Whether a spray rolls off or sticks to a plant surface depends on the physical and chemical properties of the spray mixture and the physical properties of the surface itself. If the surface tension of the mixture is high, or if the plant surface is waxy, the spray droplets will roll off.

A **spreader** or film extender (spreader-activator) is a substance that, when added to a pesticide mix, increases the area that a given volume of spray will cover and improves the contact between the pesticide and the plant surface. A spreading agent builds spray deposits and improves weatherability. Most wettable powder insecticides benefit from the addition of a spreader.

A **sticker** or adhesive is a material that, when added to a spray mix or dust, improves the adherence (tenacity) to a plant surface rather than increasing the initial deposit. Commercial sticking agents are oily in consistency and increase the amount of suspended solids retained on plant surfaces by coating the particles with a resin or varnish-like film. Most fungicides, especially wettable powders, benefit greatly from the use of stickers.

Stickers may be judged in terms of resistance to wind and water, length of adherence and mechanical or chemical action.

A **wetting agent** is a material that, when added to a pesticide, lowers the interfacial tension between a liquid and a solid; in this case, a plant surface. Effectiveness is measured by the increase in spread of a liquid over a solid surface and the ability of the spray film to make complete contact with it. When a wetting agent reduces surface tension, spreading naturally occurs.

The pesticide label should state whether a surfactant is needed or should be added to a spray mix for certain applications. The label should indicate restrictions in the selection of compatible surfactants. In many cases, surfactants have been designed specifically for use with fungicides, insecticides or herbicides.

All commercial spreading, sticking and wetting agents should be mixed strictly according to label directions. Adding more surfactant than recommended may cause excessive runoff, resulting in a poor spray deposit and reduced pest control. In general, if the spray mix contains one or more pesticides produced or formulated by the same company, use a surfactant sold or recommended by that company. Surfactants are sold separately from pesticides and are not subject to EPA registration.

Although choosing an effective surfactant to accompany a specific pesticide is no simple task, the label will state whether a surfactant is needed and the brand that should be used.

The Pesticide Label

All the printed information, including the label on the product, brochures and flyers from the company or its agent about a pesticide product is called labeling. The label printed on or attached to a container of pesticide will tell how to use the product correctly and what special safety measures need to be taken. Specific parts of the label include the following:

Brand name

Each company uses brand names to identify its products. The brand name shows up plainly on the front panel of the label.

Type of formulation

The same pesticide may be available in more than one formulation.

Ingredient statement

Each pesticide label must list the names and amounts of the active ingredients and the amount of inert ingredients in the product.

Common name and chemical name

Pesticides have complex chemical names derived from their composition. Some have also been given a shorter name or common name to make them easier to identify. Pesticides may be sold under several brand names, but the same common name or chemical name may be found on all of them.

Net contents

The net contents tell how much is in the container. This can be expressed in gallons, pints, pounds, quarts or other units of measure.

Name and address of manufacturer

The law requires the maker or distributor of a product to print the name and address of the company on the label.

Registration number

A registration number must be on every pesticide label. It shows the product has been approved by the EPA for the uses listed on the label.

Establishment number

The establishment number tells which factory made the chemical.

Precautionary statements

A section with a title similar to "Hazards to Humans and Domestic Animals" will tell the ways in which the product may be poisonous to people and animals. It will also describe any special steps necessary to avoid poisoning, such as the kind of protective equipment needed. If the product is highly toxic, this section will inform physicians of the proper treatment for poisoning.

Environmental hazards

The label tells how to avoid damage to the environment. Some examples are "This product is

highly toxic to bees exposed to direct treatment or residues on crops;" "Do not contaminate water when cleaning equipment or when disposing of wastes;" and "Do not apply where runoff is likely to occur."

Physical and chemical hazards

Lists specific fire, explosion or chemical hazards the product may pose.

Signal words and symbols

Some pesticides may be hazardous to people. Toxicity of a product is shown by reading the Signal Word and Symbol on the label.

<i>Signal Words</i>	<i>Toxicity</i>	<i>Approx. human lethal dosage</i>	<i>Symbol</i>
Danger Poison	Highly toxic	A taste to a teaspoon	Skull and Crossbones
Warning	Moderately toxic	A teaspoon to a tablespoon	none
Caution	Low toxicity; relatively nontoxic	An ounce to more than a pint	none

Highly toxic pesticides are generally not sold in the lawn and garden trade. All products must bear the statement "Keep Out of Reach of Children." In some pesticide literature, the term LD₅₀ is used to give an indication of toxicity. LD₅₀ stands for lethal dosage necessary to kill 50 percent of a test population of animals. LD₅₀ values are measured from zero up. The numbers after the 50 represent the milligrams of the substance per kg. of body weight necessary to kill 50 percent of the test population. The lower the LD₅₀ value the more poisonous a pesticide is, for example an LD₅₀ of 5 is more poisonous than LD₅₀ of 20 because only 5 milligrams per kilogram of body weight are necessary to kill 50 percent of the test population.

Statement of practical treatment

If swallowing or inhaling the product or getting it in the eyes or on the skin would be harmful, the label contains emergency first aid measures and states types of exposure requiring medical attention. The pesticide label is the most important information to take to the physician when someone has been poisoned. Without the label, it is difficult for the physician to help.

Directions for use

These instructions will explain several important items.

- The pests the product will control.
- The crops, animals or other item the product can be used on safely.
- How the product should be applied.
- How much to use.
- Where and when the material should be applied.
- Application to harvest periods.

When used on fruits or vegetables, there may be a period of time that must pass from the time of application until it is safe to pick and use the crop. Known as the application-to-harvest period and expressed as “days to harvest,” this is the time required for the residue to drop to safe levels. It is often listed as a number in parentheses following the crop name. It is a mistake to assume that a residue can be washed off.

Misuse statement

This section states that it is a violation of Federal law to use a product in a manner inconsistent with its labeling.

Storage and disposal directions

Every pesticide should be stored and disposed of correctly. This section states how to store and dispose of the product.

Application Equipment

Using the same sprayer equipment for weed control, then for insect control is neither safe nor desirable. No matter how well a tank is rinsed after the use of a herbicide, a residue will be left in the tank and in the gaskets, hoses and parts. If the same tank is then used with an insecticide to spray a plant, it is possible to kill the plant with the herbicide left in the tank. The wisest policy is to maintain two sprayers, one for herbicides and another for insecticides and fungicides. Have them clearly labeled according to use. Always wash after each use.

Pesticide application equipment comes in all shapes, sizes, types and prices (Figure 10.1). Select equipment according to common sense.

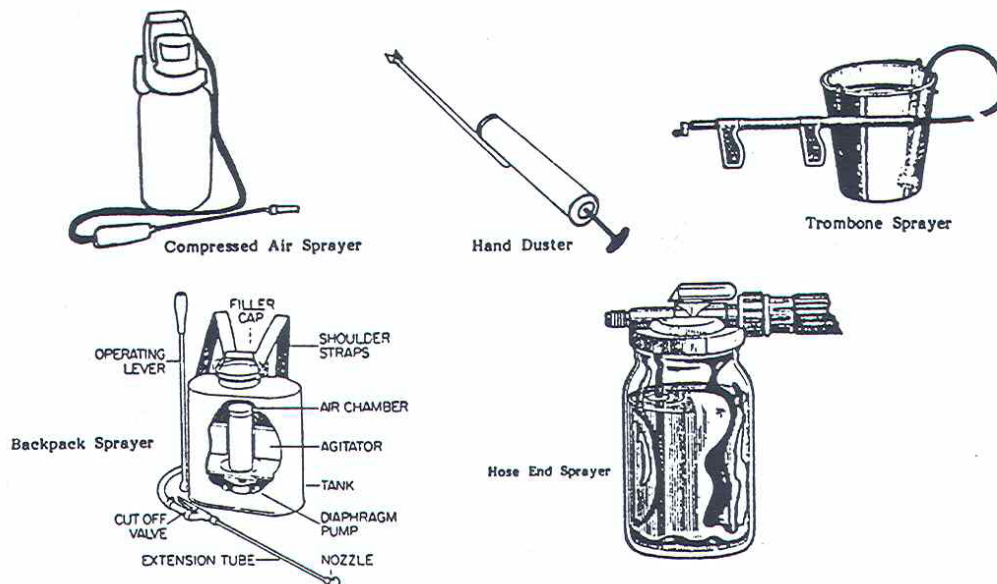

Figure 10.1. Types of applicators.

Proportioner or hose-end sprayer

These inexpensive small sprayers are designed to be attached to a garden hose. A small amount of pesticide is mixed with water, usually no more than a pint, and placed in the receptacle attached to the hose. A tube connects this concentrate to the opening of the hose. When the water is turned on, the suction created by the water passing over the top of the tube pulls the pesticide concentrate up and into the stream of hose water. The stream can reach into medium-high trees if water pressure is high. Problems are encountered from poor spray distribution and clogging of nozzles. The metering out of the concentrate into the stream of hose water is very inaccurate, since it is determined by the water pressure. Proportioners put out an excessively high volume of spray for most needs, using excessive pesticide. These sprayers are popular due to low cost, but the low purchase price is quickly negated by the cost of excessive pesticides used. All hose-end proportioners should be equipped with an antisiphon device to prevent backsiphoning of toxic chemicals into the water system.

Trombone sprayer

The trombone sprayer is a medium-sized, hand-held piece of equipment. A spray mixture in the correct dilution is prepared in a container such as a bucket. The intake tube of the sprayer is inserted into the mixture in the bucket. Pump pressure is created by operating the sprayer in a trombone-like motion. The pesticide is pulled up the hose and out the end of the sprayer. A uniform concentration of the spray can be maintained, since the pesticide is mixed with a known quantity of water. When using a wettable powder, agitate the spray mixture frequently to keep it in suspension. Trombone sprayers are excellent for spraying trees and shrubs, are easy to wash and keep clean, but require some effort to operate.

Compressed air sprayer (backpack or tank sprayer)

Spray is mixed in a small tank (generally 1 to 5 gallons) and the tank is carried on the shoulders. A hand-operated pump supplies pressure during application. A uniform concentration spray can be maintained, since the pesticide is mixed with a

known quantity of water. Frequent agitation of the spray mixture is necessary when using a wettable powder formulation. The applicator has excellent control with coverage, making this sprayer a good choice for treating dwarf fruit trees, vegetables and ornamentals. Spray will not reach into tall trees. As water weighs approximately 8.23 pounds per gallon, small tanks are easier to use than large tanks.

Either compressed-air sprayers or hose-end sprayers can be used. Hose-end sprayers do not meter out the pesticide as evenly as compressed-air sprayers. However, compressed-air sprayers do not maintain pressure as evenly as hose-end sprayers unless frequently pumped. Some hose-end sprayers will not continue to spray pesticide if the thumb hole is not covered. Other hose-end sprayers use a trigger device to control the spraying.

The spray pattern best used to cover an area of ground is one which will give uniform coverage with little spray overlap. Overlap can be a problem, causing certain areas to end up with an extra dose of pesticide. The spray pattern used to apply the pesticide should be continuous and uninterrupted. If a herbicide is being applied, the sprayer should not be slowed down or stopped at each weed. If the herbicide has been mixed correctly and the sprayer is properly calibrated, the continuous uninterrupted flow of chemical will be sufficient for good pest control.

The spray pattern should be directed so the applicator does not walk through it while spraying. The spray pattern should form an arc no more than 3 to 4 feet on either side of the operator. The sprayed area should have a small amount of overlap to ensure coverage. There can be a time when overlap may be beneficial. If good spray coverage is questionable such as when using hose-end sprayers, cut the application rate in half and apply the pesticide first in an east-west pattern, then in a north-south direction. This gives better coverage with devices typically poor in their metering capabilities (Figure 10.2).

When the mixture on the label is in teaspoons or tablespoons per gallon and the plants are upright such as shade trees, fruit trees, shrubs and vegetables, spray the leaves until pesticide solution drips from the leaves. Don't forget to spray the underside of leaves for good coverage.

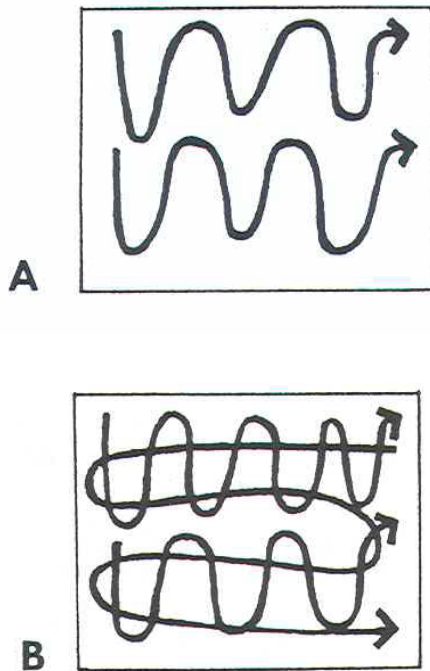

Figure 10.2. Spray pattern with a single application (A) and a double application (B).

Proper Application

When applying pesticides, wear the protective clothing and use equipment the label recommends. To prevent spillage of chemicals, always check application equipment for leaking hoses or connections and plugged, worn or dripping nozzles before adding pesticide. Before spraying, clear all people and animals from the area. To minimize drift, apply pesticides only on days with no breezes. If moderate winds come up while working, stop immediately. Reduce drift by spraying at a low pressure and using a large nozzle opening. Generally, the safest time of day to spray to reduce the hazard of drift is early morning.

Vaporization is the evaporation of an active ingredient during or after application. Pesticide vapors can cause injury. High temperatures increase vaporization. Choose pesticide formulations that do not evaporate easily, and spray during the cool part of the day to reduce vaporization. Some products, like 2,4-D, are very volatile and can move for miles with favorable conditions. They should not be used near highly sensitive plants like grapes and tomatoes. Do not apply when it is windy or when temperatures following application will reach above 85 F.

Cleaning equipment

Thoroughly clean all equipment immediately after use. Pesticides should not be stored when mixed. If there is excess mixed pesticide that cannot be used, spray it over an area that it will not harm. Check the pesticide label to determine safe areas. Thoroughly clean all spray equipment inside and out with clean water. Don't forget to flush the hoses and nozzles. Be careful that the cleaning water does not damage crops. Do not dump the rinse water in one place where it will be concentrated and may become a pollutant. Spray the rinse water over a broad area so the pesticide will be further diluted. NEVER RINSE PESTICIDES DOWN THE DRAIN!

To clean 2,4-D-type herbicides from hand spray equipment such as a 3-gallon garden sprayer, use household ammonia. Thoroughly rinse the equipment with fresh water after spraying. Fill the spray equipment with an ammonia solution, using 1/2 cup of ammonia to 3 gallons of water. Let the equipment soak for 18 to 24 hours. Always spray part of this mixture through the pump, hose and nozzles at the beginning and end of the soaking period. NOTE: 2,4-D cannot be completely removed from a sprayer once used in it. DO NOT USE THIS SPRAYER TO APPLY OTHER PESTICIDES TO DESIRABLE PLANTS.

Small power sprayers

These have the advantage of being motor-driven, so the operator does not have to stop to pump up the tank. They are lightweight, since the spray in the tank is concentrated and diluted with air as it is sprayed. Power sprayers provide uniform pressure, but are generally too expensive for home garden use.

Hand duster

The duster may consist of a squeeze tube or shaker, a plunger that slides through a tube or a fan powered by a hand crank. Uniform coverage of foliage is difficult to achieve with many dusters. Dusts are more subject to drift than liquid formulations due to their light weight and poor sticking qualities.

Calibrating Sprayers and Spray Patterns

The usual approach consumers use when applying a pesticide on a given area is to mix a tablespoon or two of a certain pesticide and apply it to a problem area. This is acceptable, if the label gives recommended rates in teaspoons or tablespoons per gallon. But some pesticides, specifically herbicides and insecticides for lawns, do not give rates in tablespoons or teaspoons per gallon. Instead, they give rates of application in teaspoons or tablespoons per 100 or 500 square feet. Unfortunately, the consumer all too often solves this problem by guessing how much to use. This can be dangerous; too concentrated may be too toxic; too little will not control the problem. It is irresponsible of the consumer to apply chemicals at improper rates. It is dangerous to him/herself, neighbors and the environment.

A better approach is to calibrate the sprayer. The calibration of a home sprayer is relatively easy. Once it has been done, it has been done for the life of the sprayer, provided the nozzle remains unchanged, clean and adequate pressure is used. It must be kept in mind that the rate at which the liquid is applied varies with the pressure and size of the opening in the nozzle. High pressure and a large opening in the nozzle permit more liquid to be applied over a given area than low pressure and/or smaller nozzle. For calibrating a sprayer, the procedure is as follows:

1. Fully pressurize the sprayer and determine delivery time. This is done by spraying water through the sprayer into a pint jar. Mark this delivery time on the sprayer for future use.
2. Calculate the area to be treated. Measure the area to be sprayed. Multiply length times width to determine the area of a rectangle. The area of a triangle is calculated by multiplying the base times the height and dividing by two. Most areas can be calculated by combining rectangles and triangles or subtracting triangles from rectangles.
3. If the area is large, divide it into sections equal to the size of the delivery area.
4. Spray an area with water, at normal walking speed, for 30 seconds. Measure the area sprayed. This tells how much area can be sprayed in 30 seconds, and therefore, the

amount that is applied over that area (see item 1). For example, assuming it has been established: 30 seconds of spraying delivers 1/2 cup and 30 seconds of spraying will cover 100 square feet; then 1,000 square feet require 5 cups spray (.5 x 10) delivered or 1 quart + 1 cup or 40 ounces (if the label calls for 3 tablespoons of pesticide for 1,000 square feet). Then, 3 tablespoons of pesticide must be mixed with 40 ounces of water to achieve proper spray coverage. Many commercial-type chemicals are given in pounds to the acre or quarts to 100 gallons of water. To convert rates to equivalents used by a consumer, consult the pesticide conversion chart at the end of this chapter.

Storage and Disposal

Gardeners should store all pesticides in their original containers, in a **locked cabinet. NO EXCEPTIONS IF YOU ARE CONCERNED ABOUT CHILDREN'S LIVES!** They should be protected from temperature extremes, some can be damaged upon freezing, others can be altered by heat. Do not store pesticides in the home! Empty containers are best placed in refuse cans destined for a sanitary landfill. Wrap containers in newspaper and secure before disposal. Some states have special chemical dumps for pesticides; however, some do not have such dump sites. The bottle should be rinsed out first, pouring the rinse water into the spray tank. Rinse three times, allowing 30 seconds to drain between each rinse. Never use empty pesticide containers for other uses, never allow children to play with empty containers. If possible, break the containers before disposal. Do not burn paper containers.

Using Pesticides Safely

Protective Clothing

If special protective clothing is required, the label will tell what kind of protection to use. Pesticides sold in the home garden trade generally do not require special protective clothing. Many professionally used and highly toxic chemicals do. When handling pesticides, wear a long-sleeved shirt and long-legged trousers (or a coverall-type garment) and shoes. Additional protection is available by wearing unlined neoprene or rubber gloves,

a wide-brimmed plastic hard hat that covers the back of the neck and goggles or a face shield to protect the eyes. Rubber gloves and goggles are particularly important when mixing or pouring pesticides. Toxic commercial pesticides may also require neoprene boots, chemical cartridge respirators, face masks, neoprene suit or even gas masks. These more toxic chemicals should not be used in a home garden setting. After using any pesticide, wash your hands and arms thoroughly with soap and water. Never eat, drink or smoke before washing your hands. If you have been doing a lot of spraying or dusting, remove your clothes, take a shower and put on clean clothes. Clothing should be laundered separately from the family wash. The washer should be run empty with detergent after cleaning pesticide-contaminated clothing. If you get sprayed, change and shower immediately. Use first aid procedures if necessary.

Safety Precautions

Most pesticides can cause severe illness or even death if misused. Still, every registered pesticide can be used safely. Many accidental pesticide deaths are caused by eating or drinking the product, particularly by young children. Some applicators die or are injured when they breathe a pesticide vapor or get a pesticide on their skin. Pesticides can poison two ways. Acute poisoning, or toxicity measured by an LD₅₀ number, can kill or injure after one exposure. Chronic toxins, on the other hand, will not produce an effect until there have been a sufficient number of exposures. However, the number of exposures necessary to produce an effect varies with the kind of pesticide and the health and size of the person exposed. LD₅₀ is not a measure for chronic toxicity. If an applicator uses organophosphate (diazinon, malathion) or carbamate (carbaryl, furadan) insecticides with any regularity, it would be wise to ask a physician about a test to check the cholinesterase level of the blood. These pesticides destroy this enzyme, which is necessary to carry nerve impulses to the brain. Although chronic toxicity is not poisonous immediately, during the long term it can be serious. Always use safety precautions and treat all pesticides with respect. To prevent accidents with pesticides, use and store pesticides away from children, keep pesticides in their original containers and take care to always follow label directions.

Symptoms of Pesticide Poisoning

Awareness of the early symptoms and signs of pesticide poisoning is important. Unfortunately, all pesticide poisoning symptoms are not the same. Each chemical family (organophosphates, carbamates, chlorinated hydrocarbons, etc.) attacks the human body in a different way. Fumigants and solvents can make a person appear to be drunk. The symptoms are poor coordination, slurring of words, confusion and sleepiness. Common pesticides like organophosphates and carbamates injure the nervous system. The symptoms develop in stages, usually occurring in this order:

Mild Poisoning or Early Symptoms of Acute Poisoning: Fatigue, headache dizziness, blurred vision, excessive sweating and salivation, nausea and vomiting, stomach cramps or diarrhea.

Moderate Poisoning or Early Symptoms of Acute Poisoning: Unable to walk, weakness, chest discomfort, muscle twitches, constriction of pupil of the eye, earlier symptoms become more severe.

Severe or Acute Poisoning: Unconsciousness, severe constriction of pupil of the eye, muscle twitches, convulsions, secretions from mouth and nose, breathing difficulty, death if not treated. Illness may occur a few hours after exposure.

If symptoms start more than 12 hours after exposure to a pesticide, it is likely caused by some other illness. Check with a physician to verify.

First Aid Procedures

Read the "Statement of Practical Treatment" on each label. The directions listed can save lives. If a pesticide gets on the skin, remove the substance as quickly as possible. Remove all contaminated clothing. Prompt washing may prevent sickness even when the spill is very large. Detergents work better than soap in removing pesticides. Don't forget the hair and fingernails. If a pesticide is inhaled, get to fresh air right away. Loosen all tight-fitting clothing. If needed, give artificial respiration immediately – do not stop until victim is breathing well or medical help arrives. Get the victim to a physician. Do not administer anything to a poison victim unless you are trained in first aid, otherwise you may compound the injury.

In case of poisoning, call a physician and give the following information: describe the victim by name, age and sex, and identify yourself and your relationship to the victim. Have the package or poison in hand and identify what the victim took

and how much was taken. Keep calm – there is enough time to act – but don't delay unnecessarily. For information about poison control centers in your state, ask the local Extension educator for a listing. Poisoning information is also available by contacting a local poison control center.

Pesticides and the Environment

Direct Kill

Fine mists of herbicides can drift to nearby crops or landscape plants and kill them. Bees and other pollinators can be killed if a crop is treated with a pesticide when they are in the field. The natural enemies of pest insects can also be killed by pesticides. Life in streams or ponds can be wiped out by accidental spraying of ditches and waterways, runoff from sprayed fields and careless container disposal. If more than one pesticide will control the pest, choose the one that is the least hazardous to the environment and most useful for the situation. To protect beneficial insects, avoid excessive use of insecticides – spray only when necessary to protect the crop and control pest populations.

Protecting Insect Pollinators

Gardeners should give special consideration to protecting insect pollinators, such as the honey bee, from insecticide poisoning. Insecticides highly toxic to bees have restricted application times when being applied to crops frequented by honey bees. Bees are not active in late evening and early morning. Do not apply insecticides when temperatures are unusually low because residues will remain toxic much longer.

Persistence and Accumulation

Although most pesticides break down quickly, remaining in the environment only a short time before being changed into harmless products, some break down slowly and stay in the environment for a long time. These are called persistent pesticides. Some persistent pesticides can build up in the bodies of animals, including people. These pesticides are called accumulative. Most persistent pesticides have very limited usage or have been removed from the market. For example, chlordane is a persistent pesticide and its use is limited to termite and fire ant control.

Pesticides Move in the Environment

Pesticides become problems when they move off target. This may mean drifting off the target in the form of dust or mist, moving with soil particles by erosion, leaching through the soil, being carried out as residues on crops or livestock or evaporating and moving with air currents.

Safe Use Precautions

Following safety precautions and using common sense can prevent harm from pesticides. Here are the minimum safety steps to take:

- Before buying a pesticide, identify the pest to be controlled. Then find out which pesticide will control it. If there is a choice of several, choose the least hazardous product.
- Before purchase, read the label of the pesticide to ensure the host plant (and pest) is listed on the pesticide label and the pesticide is not phytotoxic to the plant being protected. Also check safety conditions for use, such as special equipment, protective clothing, restrictions on use and environmental precautions needed.
- Before applying the pesticide, read the label again to be sure of proper application and safety measures, including protective clothing and equipment needed, the specific warning and precautions, with what it can be mixed, mixing instructions, application to harvest period for fruit and vegetables, crops to which it can or cannot be applied and other special instructions.

Compatibility

Compatibility occurs when two or more pesticides can be mixed together without reducing their effectiveness or harming the target. For instance, carbaryl (Sevin) is often combined with a miticide such as Kelthane to kill both insects and mites at one time. Synergism is the action of two materials of the same type, which when used together, produce a greater effect than the sum of the materials when used alone. One of the materials when used alone may not affect the pest, but greatly increases the total effect of the two when used together. Example: Chemical A kills 60 percent, Chemical B kills 20 percent, Chemical A and B together kill 90 percent of the pests. Synergism may increase control or require less chemical. It also may be more harmful to a nontarget organism. A synergis-

tic effect can also be undesirable, causing death or damage to the organism being protected. It should be stressed that no chemicals should be mixed together unless the label specifically says they are compatible.

Home Garden Versus Commercial Pesticides

Some pesticides are packaged specifically for home garden use. These products are packaged in small quantities, i.e. pints, quarts, ounces or pounds. They are seldom highly toxic pesticides and are usually in low concentrations. The label rate is given in spoonfuls per gallon or pounds per 1,000 square feet.

Because of the small label size, home garden products may not list all of the plants and/or pests for which the product may be registered for use. For example, one manufacturer sells Diazinon 25 percent EC as Fruit and Vegetable Insect Control and Diazinon Insect Spray. Both are basically the same product, but plants and pests listed vary greatly. This situation causes some confusion in pesticide application and stimulates the purchase of excessive amounts of pesticides.

Products packaged for the commercial grower may appear to be less expensive, but consumers should not be tempted to use them. They are generally more toxic than those for home use and require special protective clothing and equipment for application. These products are more concentrated and in larger containers than the consumer could expect to use or safely store. They also are much more difficult to calibrate and mix correctly, since rates are usually based on a per-acre system.

A few products extremely toxic to humans or the environment are classified by the EPA as RESTRICTED USE PESTICIDES. The label will state "restricted use pesticides for retail sale to and application only by certified applicators, or person under their direct supervision." A license from the State Department of Agriculture is required by law for purchase and use of restricted use pesticides. This licensing is intended for commercial growers and does NOT automatically clear the use of these products by the home gardener. If pesticides from the commercial trade must be used, use extra caution to protect yourself, your family and the environment.

Pesticides and Organic Gardening

Although it is questionable whether we could raise all crops without the use of pesticides, it is certainly true that we can reduce the amount of pesticides we use by careful and efficient use. There are some steps to consider before automatically turning to a pesticide. First, determine if control measures are really needed. Is the problem severe enough to warrant treatment? If the cost of treatment is less than the predicted loss, the economic threshold has been reached, and treatment is necessary. Consider alternative control measures. Some examples are cultivating instead of using a herbicide, and removing and destroying diseased plant parts rather than using a pesticide.

The next step is integrated control. This is probably the best answer to pest control. In this situation, the wise use of pesticides is combined with alternative methods, such as conservation practices, to encourage natural enemies of the pest. For example, a simple integrated control program could be used on a golf course for grub-proofing against Japanese beetle larvae. A chemical pesticide would be used to protect the more valuable sodded areas of the fairways. Milky spore disease, which is commercially produced biological control for Japanese beetle larvae, would be applied in the roughs. The chemical pesticide would give immediate protection to the sodded areas, while the milky spore disease becomes established in the rough. Then, as the chemical breaks down in the more valuable areas, milky spore disease would move in. Once milky spore disease is established, no more chemical treatment is usually needed to protect the turf.

Pesticides and the Law

In Oklahoma, the registration and use of pesticides are governed by the EPA and the Oklahoma Department of Agriculture, Food and Forestry. Under the amended Federal Insecticide, Fungicide and Rodenticide Act (Federal Environmental Control Act of 1972) it is illegal to use a pesticide on a crop unless the crop is listed on the label. You may not exceed the given rate of application on the label. Fines and other penalties change and vary according to laws broken.

Under the law you are liable for misuse of pesticides on your property. Recent court rulings extend your liability to include misuse by commercial applicators you hire. Serious misuse by gardeners usually results from drift, leaching of a pesticide onto non-target plants or the direct treatment of the plant by a wrong pesticide.

Pesticide Conversion Chart

The measurements given below are approximate and should be used as a general guideline if the directions for mixing small quantities are not given on the pesticide label.

Liquid Measure:

Amount per 100 gallons	Amount per gallon
1/4 pint	1/4 teaspoon
1 pint	1teaspoon
1 quart	2 teaspoons
1 gallon	2 1/2 tablespoons
2 gallons	5 tablespoons
4 gallons	1/3 pint
11 gallons	7/8 pint

Dry Weight:

Amount per 100 gallons	Amount per gallon
1/2 pound	1/12 ounce
1 pound	1/6 ounce
2 pounds	1/3 ounce
3 pounds	1/2 ounce
4 pounds	2/3 ounce
6 pounds	4/5 ounce
16 pounds	2 3/5 ounce
20 pounds	3 1/5 ounce

Integrated Pest Management

Integrated Pest Management (IPM) is very compatible with sustainable gardening; in fact, it is a key component of sustainable gardening. The beauty of IPM is that it can be tailored to work in any environment, be it an organic garden or a school building, a natural forest or a highly man-

aged city park. We will spend some time learning more about IPM and show you how it can be deployed into a landscape and garden.

What is IPM?

IPM is an acronym for a strategy called Integrated Pest Management. IPM is a strategy to manage pests in a way that is economically feasible, environmentally responsible, and minimizes risk to the health of humans and non-targeted organisms. There are more than 60 published definitions of IPM, but one that is preferred is:

“IPM is a sustainable approach that combines the use of prevention, avoidance, monitoring and suppression (PAMS) strategies in a way that minimizes economic, health and environmental risks.” (USDA-CSREES, 1998).

A well-designed IPM program CARES meaning that it is:

- Comprehensive because it combines all effective tools (both preventive and corrective) that are applied when needed (monitoring) and considers multiple pests.
- Adaptable because it can be modified to address any pest situation that arises.
- Responsible because it is based on sound science and does least harm to people and the environment.
- Economical because it is cost effective, and will provide profitable pest management.
- Sustainable because it reduces pest problems over the long-term.

Does IPM mean eradication?

Before we go any further, let's be clear about what a pest is. A pest is any living organism that is “out of place.” The problem is that a “pest” does not know that it's a “pest.” That term is one that we place on an organism. Those “out of place” organisms actually play an important role in our ecosystem. Many homeowners are intolerant of pests that invade their home or landscape. IPM would not be a good solution for those that expect the total elimination of a pest. So, IPM is really a system designed to eliminate, through management, pest problems, not the pests themselves.

IPM means management!

We should think of IPM as an approach designed to manage pests by manipulating the abi-

otic (non-living) and biotic (living) elements of an ecosystem (the home they live in) so they are unfavorable for the establishment and survival of the pests in question. We can do this through the use of a set of preventive and corrective “tools” that when applied, encourage desirable organisms and deter undesirable pests.

Why was IPM “invented”?

IPM was developed in response to a crisis that was occurring in the 1950's and 1960's. Pesticides, particularly insecticides, were being heavily relied upon to control pests on farms and urban areas. Rachael Carson published an important book; “Silent Spring” in 1962 that highlighted how the indiscriminant use of pesticides was causing unintended changes in our environment. In addition, numerous problems were developing because of overreliance of insecticides to control pests throughout the world. Initially Carson's assertions received a negative response from the scientific community, but many of her observations about the effects of pesticides on the environment were scrutinized and the effects she exemplified in her book became undisputable. Her book served as one catalyst for the growth of the environmental movement in the 1960's and 70's and the enforcement of the Federal Insecticide, Fungicide, and Rodenticide Act from USDA to the EPA.

The initial concepts of IPM were proposed long before the term “Integrated Pest Management” was coined. Dwight Isley outlined various cultural, mechanical and monitoring tactics for control of boll weevil in 1929. A paper written by Vernon M. Stern and colleagues titled “The Integrated Control Concept”, written in 1959 V.M. Stern and colleagues is credited as the first description of what would become IPM, but plant pathologists correctly point out that they were “doing IPM” long before the term was coined, as they had very few fungicides available to use for plant disease control until more recently. IPM received important recognition in 1972 because of a number of events regarding pests and pesticide use that converged at that time and it continues to evolve as a framework for managing pests.

Designing an IPM “Master Plan” for Your Garden

Think of IPM as a “system” to manage pests. The system involves FIRST using tactics to avoid, prevent or minimize pests from establishing in a garden. The system also can use corrective tactics, such as pesticides judiciously once a pest becomes a problem. Such a system requires planning, scouting, record keeping, and education in order to put it together. Once developed, it should be sustainable and flexible so it can be adjusted slightly for problems that arise.

A key to developing and practicing IPM is to MONITOR. Regularly check your garden for signs and symptoms of pests and pest damage. It takes some practice to become proficient at monitoring. Plants in the garden need to be thoroughly inspected. It would be good to keep records of what you find, including what insects are feeding, what plant diseases are developing and what weeds are growing. To really do a good job, you will need some tools, such as a 5X to 15X hand lens, some plastic bags, a small trowel or pocket knife, and maybe a flashlight to scout at night. Additional tools can include a bucket, a shake cloth and some plastic vials with snap caps.

When you find a pest, it is important to properly identify it. There are many references and websites that can help with identification. If you are still stumped, ask an experienced Master Gardener or a county or state Extension educator. Once the pest is identified, a world of information can be gathered on its biology, life cycle and life history. This information can help with determining the most effective and least disruptive methods for control.

Let's think about what a pest needs to survive. Plant pathologists developed a Plant Disease Triangle (Figure 10.3) as a concept to show what is needed for a plant disease to develop. For a plant

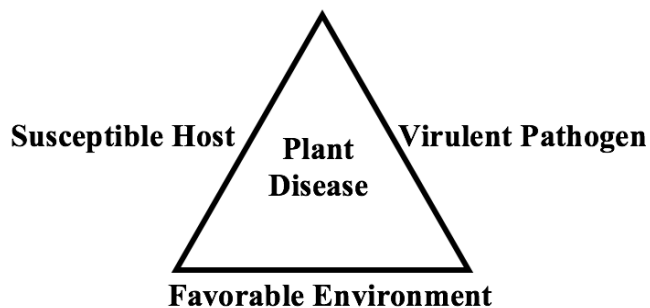

Figure 10.3. The disease triangle.

disease to develop, it needs a susceptible host, a virulent pathogen, and a favorable environment.

A similar “triangle” can be thought of for an invertebrate or vertebrate infestation to develop (Figure 10.4). A pest needs food, water and shelter to survive and thrive. Take away one or more of those needs, and the pest population should be manageable.

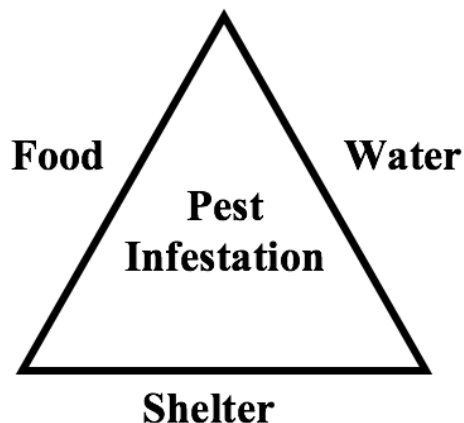

Figure 10.4. Triangle for an invertebrate or vertebrate infestation.

Once you have put a plan into action, it is important to follow up with evaluation to make sure you have obtained effective results. You can easily do this as you continue to MONITOR.

Putting an IPM “Master Plan” Together

We can approach the development of an IPM “Master Plan” by using Preventive, and Corrective Tactics. Preventive tactics include: Do Nothing, Cultural, Biological, Mechanical/Physical/ and Regulatory controls. Corrective tactics include some Biological, Cultural, Mechanical and Regulatory tactics, but most often, we think of Chemical tactics, such as pesticides. Think of IPM as a pyramid, with a solid base of prevention that can support carefully applied corrective tactics when needed (Figure 10.5).

Do nothing

Sometimes it is simply not necessary do anything, because the pests are not numerous enough to be a problem in the garden.

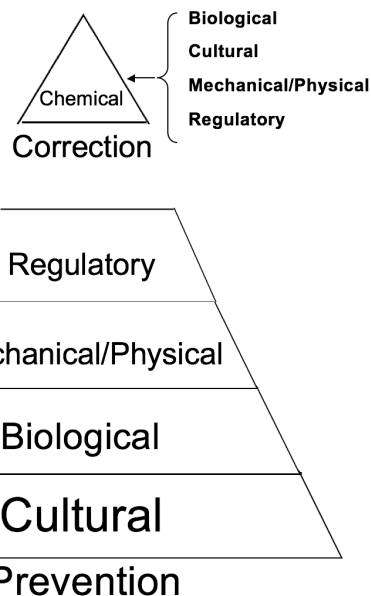

Figure 10.5. The IPM pyramid.

Cultural tactics

Cultural tactics include things that are done in conjunction with growing the plants that keep them healthy, or address pest problems. They include things like:

- Choosing resistant or tolerant plants
- Choosing healthy plants
- Proper placement in the landscape
- Giving them all of the things that they need to stay healthy (good horticulture)
- Good garden “sanitation”
- Crop rotations
- Trap crops/companion plantings
- Green manures and cover crops

The plants one chooses to grow will affect the pests that will be encountered. Spend some time learning about the specific plant species, and the varieties or cultivars within that species that are adapted to Oklahoma’s growing conditions. Choose plants that are less likely to have pest problems. Oklahoma Proven varieties <http://www.oklahomaproven.org/> have been evaluated by Horticulture faculty at OSU for their wide adaptability under Oklahoma growing conditions.

Plant varieties are often developed to be resistant or tolerant to a variety of plant diseases and insect pests. When selecting varieties, look for their resistance package and ask a knowledgeable

person about their ability to resist diseases. Some common diseases, such as black spot of roses, scale on *Euonymus*, or virus diseases on vegetables can be avoided by researching and choosing resistant cultivars.

When getting transplants or new plants from a retail nursery, inspect them for evidence of disease, insect damage, or other stresses before taking them home. Make sure container plants are not root bound and are in a sterilized potting medium.

Place plants in the correct environment for them to thrive. For example, don't put plants that require partial shade in full sun; don't put plants that need acidic soils in an alkaline soil, or plants that require well-drained conditions into a low, waterlogged spot. If a landscape doesn't have the proper conditions for a specific plant, DON'T BUY IT!

Once plants have been placed in their new home within a landscape, give them everything they need to thrive. Don't over or under fertilize, over or under water, or change the pH by using soil amendments that can change the pH of the soil. Provide them with mulch, or other organic matter to improve drainage and "soil health."

Keep the garden "clean." That means use proper sanitation to prevent spread of disease, or simply keep the area free of dropped fruit, dead branches or infested plant material. Keep the garden weed-free. Keep garden tools clean, and sterilized with rubbing alcohol or a weak bleach solution. Eliminate hiding places for rabbits and other unwanted animals.

Rotate annual crops by plant families. Many insects and diseases are "picky" about which plants they will attack. If plants within the same family are grown in the same place year after year, pests, such as nematodes, soil-dwelling insects and soil-borne diseases can build up. Change the "family" of annual plants that are grown in a spot each year.

Use trap crops and companion plantings to disrupt pests. Trap crops are a way to concentrate a pest into a small planting of a preferred plant in order to protect the main crop from infestation. Other types of companion planting can include using a plant that "repels" another pest. A third type is to plant a companion plant that serves as a habitat for some natural enemies.

Green manures and cover crops are a way to increase the organic matter in a soil, and suppress weeds. They work much like a "living mulch." Some green manures, such as wild brown mustards, can naturally fumigate a soil, suppressing some weeds. There are also claims that they can suppress soil-borne disease organisms, but research in California has shown that they have minimal effect on *Verticillium* or *Fusarium*.

Biological tactics

There are numerous natural enemies of pest insects in a landscape. A gardener can take advantage of these natural enemies by providing them what they need to "hang around." Again, it becomes important to know something about the various natural enemies that are native to Oklahoma, and about those that can be purchased commercially to control some pests, particularly in the greenhouse. There are three types of natural enemies of insects; predators, parasitoids and pathogens. Predatory arthropods can be known because they are typically larger than their prey, and they eat large numbers of prey. They are more often not very discriminating about what insects they eat, both beneficials and pests. Some, like ladybeetles, and syrphid fly larvae, eat mostly aphids, but others eat a wide variety of prey.

Parasitoids are arthropods that live on or in a host insect, and kill it in the process. Most are smaller than their hosts and are narrow in what

Table 10.1. Crops by plant families.

Beet family	Chenopodiaceae	beets, spinach, Swiss chard
Carrot family	Apiaceae	carrot, celery, fennel, parsley parsnip
Cucurbit family	Cucurbitaceae	cucumber, melon pumpkin, squash
Cole crop family	Brassicaceae	bok choy, broccoli, Brussels sprout, cabbage, cauliflower, collard, kale, kohlrabi, mustard, radish, rutabaga, turnip
Legume family	Fabaceae	beans, peas, vetch
Lettuce family	Asteraceae	Chicory, endive, globe artichoke, lettuce
Onion family	Liliaceae	Chive, garlic, leek, onion, shallot
Tomato family	Solanaceae	Eggplant, pepper, potato, tomatillo, tomato

they consume for prey. Because they are so small, they often are not noticed in the garden.

Insects also are attacked by pathogens, including nematodes, fungi, bacteria, and viruses. Some common ones include *Beauveria bassiana* (a fungus), *Heterorhabditid* and *Steinernematid* nematodes, and baculoviruses. A beneficial fungus, *Gliocladium virens* (GL-21) can be mixed into growing media to suppress the plant pathogens that cause damping-off disease.

Gardens can include plants that attract or conserve beneficial insects. Many adult predators and parasitoids feed on nectar and pollen as part of their diet. They need shelter as well.

A few examples of plants that can be planted in the garden that are known to be attractive to beneficial insects:

Umbelliferae: Caraway, Coriander (cilantro) Dill, Fennel, Queen Anne's lace

Compositae: Blanket flower, Coneflower, Coreopsis, Tansy, Yarrow

Fabaceae (legumes): Sweet clover, vetches

Brassicaceae: Sweet alyssum, Yellow rocket, Wild mustard.

From "Manage Insects on Your Farm," Altieri et al. 2005 <http://www.sare.org/publications/insect/index.htm>

To learn more about identifying and conserving natural enemies, consult Extension Circular E-1023, *Conserving Beneficial Arthropods in Residential Landscapes*, which can be obtained through your county extension office. Also, consult HLA-6434, *Earth-Kind Gardening Series: Biological Pest Controls* for more information.

Mechanical/physical tactics

Mechanical and physical tactics include the use of barriers, traps, or heat, cold or physical removal to prevent or reduce pest problems.

Here is a list of mechanical and physical tactics that can be used:

- Hand picking
- Streaming with water
- Pruning
- Barriers
 - Horticultural fabrics and floating row covers
 - Plant cages

- Plant collars
- Sticky barriers
- Metal barriers
- Weed barriers
- Plastic Mulches
- Rototilling
- Mowing
- Trapping
 - Sticky traps
 - Pheromone traps
 - Slug traps
 - Light traps
- Cultivation
- Flaming
- Heat/cold treatments

Chemical methods

We typically think of chemical controls as corrective methods. Some of the preventive methods that have already been talked about can also be corrective, and sometimes chemical controls can be preventive (such as pre-emergence herbicides, or seed treatments for disease and insects). However, most of the time chemical controls are applied to correct a problem that has arisen.

It is important to consider that every time a pesticide is applied, we are deliberately choosing to put a poison into the environment. Therefore, carefully consider the need for applying a pesticide. They should only be used when other controls don't provide satisfactory control. Also, choose the pesticide that is least harmful while still being effective (least harmful to the environment, to the applicator and to beneficials). Also, apply pesticides strictly according to the label, and apply in a manner that minimizes effects on beneficials and non-targets (use only when and where needed).

Some pesticides are less hazardous than others. For example, insecticidal soaps, horticultural oils, diatomaceous earth and kaolin clays are effective and are very low-hazard options. There are microbial and botanical pesticides that are target-specific or less toxic to non-target organisms. Finally, there are synthetic chemistries that are very target-specific and less hazardous. If a more toxic pesticide is needed, apply in a safe manner, apply as little of area as needed and apply strictly according to the label.

Chapter 11: WILDLIFE

Learning Objectives:

After completing this section, Master Gardener trainees will be able to:

- Be familiar with the common wildlife found in Oklahoma and the damage they cause to home landscapes.
- Be familiar with the different categories of control and which are most likely to provide desired results.

Chapter 11: Wildlife.....	377
Introduction	377
White-tailed Deer.....	378
Easter Cottontail	380
Armadillo	381
Pocket Gopher	382
Mole.....	384
Woodpecker	385
Canada Geese	386
Tree Squirrels.....	387
Northern Raccoon	388
Striped Skunk	389

Introduction

Many gardeners enjoy attracting wildlife into their landscapes. However, some species of wildlife can become problematic if they damage plants or structures in the landscape. This chapter will cover the most common wildlife damage complaints. However, this chapter it is not intended to be an exhaustive list of all wildlife species that can cause damage. The topic of wildlife damage management is quite broad and includes such issues as structure damage, human health and safety, impacts between wildlife species and nuisance. The focus on this chapter is on direct impacts to plants and landscapes. For additional information on the broader field of wildlife damage management or for other wildlife species not covered here, see the appendix at the conclusion of this chapter.

For each wildlife species in this chapter, examples given are proven to work from the categories of lethal control, repellents, frightening, exclusion and habitat modification. However, some generalities should be noted. Lethal control is typically the first attempted by gardeners. However, it is often the least effective. If the resource that attracted the animal still exists, additional wildlife will likely be attracted to that resource. Thus, lethal control becomes a continual effort. While it may seem cheaper than other methods, labor costs and lost opportunity (such as time spent gardening) should be taken into consideration. Repellents also are frequently used to reduce damage. While repellents can provide relief in some cases, they are often very temporary, expensive and labor intensive. Frightening is similar to repellents because it generally provides temporary relief and is generally labor intensive. However, there are some notable exceptions covered in this chapter where frightening is effective. Exclusion (separating the wildlife from the resource) can be highly effective for some species and completely impractical for others. While often costly on the front end, in the long term it can be quite cost effective. However, fences and netting may detract from the aesthetics the gardener is seeking. Modifying the landscape is generally not utilized by gardeners. This is unfortunate, as it is often the best way to reduce damage. Simply changing the species of plants in the landscape can reduce damage from many wildlife species.

One issue gardeners should consider before implementing any control is to examine their per-

sonal tolerance level for damage. What may be considered a minor inconvenience to one gardener may be completely unacceptable to the next. This is not a trivial matter, as it determines when and where management is applied. Individuals will need to determine when damage levels warrant management (within the constraints of the law). However, implications of certain treatments and the beneficial aspects of some animals will be discussed so an informed decision can be made. Gardeners may notice that some management options for certain species are omitted in this chapter. Only practical and proven techniques will be covered. Other management techniques may work, but this chapter will cover the techniques with the highest probability of success. Gardeners should be aware there is seldom a quick and easy fix to any wildlife damage problem. Often, the cost (time and money) of control exceeds the damage. Yet management decisions are not based purely on economic decisions, but rather on personal preferences. Many wildlife damage issues are primarily nuisance rather than actual damage to plants or structures. Whether the nuisance warrants control is related to the tolerance and preference of the individual gardener.

White-tailed Deer

This ubiquitous animal is abundant statewide. It has a broad diet and can reach plants up to about 6 feet from the ground. While deer consume many types of plants, they are browsing animals that prefer woody plants (shrubs, vines and young trees) and herbaceous broadleaf plants such as black-eyed Susan, pansy and hosta. Grasses are generally not consumed in great amounts except for cool season grasses in late winter when other food resources are limited. Deer lack upper incisors, thus deer damage is obvious as the vegetation will have a torn appearance. Also, look for oblong or clumped dark droppings near damaged plants or the cloven hoof print typical of all deer. On woody plants, deer typically consume the most recent growth (tips), leaving the more woody, older portions of a plant untouched. Thus, woody plants are typically not killed, but can have an unsightly appearance.

Lethal Control

Deer are a regulated game species and may not be killed except as permitted by the Oklahoma Department of Wildlife (<http://wildlifedepartment.com/>) during regular hunting seasons. However, it is possible to receive special depredation permits for animals causing damage under some circumstances, such as damage to a commercial crop. Hunting is generally not an acceptable option for gardeners within the city limits as ordinances prohibit discharge of firearms, although some urban areas permit archery hunting. In rural areas, hunting may provide some relief; however, killing one or two animals will have minimal impact on damage levels. Thus, for most gardeners, hunting will not be a viable solution.

Repellents

There are a multitude of commercially available and homemade repellents, advertised as effective at reducing deer damage to plants. Repellents are either area (smell) or contact (taste). Contact repellents are more effective, as they directly contact the plant being protected, thus deter ingestion. Most repellents have been found to provide limited effectiveness (Table 11.1). There are two notable exceptions. Repellents which include putrid egg solids or are thiram based have the highest reported effectiveness (70 to 99 percent and 43 to 78 percent, respectively). A problem with all repellents is they must be applied to a large portion of the plant to provide protection. Additionally, applications must be reapplied frequently. Expect to reapply every couple of weeks at minimum. Rain will cause more frequent reapplication. Areas with higher deer density and/or lower food resources will have reduced effectiveness from repellents. Also, the more preferred the target plant, the less effective the repellent will be.

Frightening

Frightening can provide relief, particularly when used in combination with other methods. Scare tactics are also more effective when deer numbers are low or the food resource is marginally attractive to deer. Many scare tactics use loud noises. Unfortunately this is not only disturbing to deer, but to the homeowner and neighbors. Thus, it is not typically useful for the home gardener. Deer are frightened by dogs, and their presence in a neighborhood often greatly reduces deer damage for the area.

Table 11.1. Comparison of damage reduction with commonly used area or contact repellents.

<i>Class of Repellents</i>	<i>Percent Reduction of Damage</i>
Area	
bone tar oil	15-34
ammonia soaps of higher fatty acids	43
human hair	15-34
bar soap	38
blood meal	NE ^a
cat/dog feces	NE ^a
moth balls	NE ^a
human sweat	NE ^a
putrefied meat scraps	NE ^a
Contact	
putrescent egg solids	70-99
Benzyldiethyl ammonium saccharide	<15
Hot Sauce (Capsaicin)	15-34
Thiram based	43-78

^a NE—generally considered not effective.

Invisible dog fences (underground containment systems) can be used so dogs can see and harass deer. However, frequent barking may become more of a nuisance than the deer.

Exclusion

Exclusion is a very effective way to minimize damage to landscape plants. However, it can be expensive because fences need to be 10 feet tall to completely exclude deer (Figure 11.1). Woven wire is the most effective, but high tensile wire spaced 12 inches apart works as well. For large areas of a high value plant (such as a garden), this may be the best long-term solution. If a fence of this height is not an option, shorter fences can be utilized with varying success. Typically, these will employ an electric wire(s) to provide further deterrence. A simple fence for small garden plots uses a single electric wire with pieces of aluminum foil (or other electrical conducting material) attached at about 3-foot intervals. Peanut butter smeared onto the conductors serves as an attractant (Figure 11.2). The resultant shock can condition deer to avoid that area. While this method is not foolproof, it is



Figure 11.1. Fences must be 8 to 10 feet to fully exclude deer. This is a substantial investment and is not practical for large areas.



Figure 11.2. A “peanut butter” baited fence can help reduce damage to small garden plots or landscapes. The aluminum foil acts as a conductor to deliver an electrical shock to condition deer to avoid the area.

cheap and easy to try for small areas. Note: It can be difficult to get a proper ground for an electric fence, particularly when the soil column is dry. For individual trees, the trunk may be wrapped with plastic tree wrap or a wire mesh cylinder placed around the tree (Figure 11.3). The cylinder should be at least 4 feet tall. If branches are within the reach of the deer, they may still browse the tips. Ensure that the wrap or wire is not cutting into the bark of the tree.



Figure 11.3. When using tree guards, make sure there is space between the wire/plastic to allow for tree growth and to minimize disease and insect problems. The tree guard should be at least 4 feet tall to minimize deer rubbing their antlers. For herbivory damage, it may need to be up to 6 feet.

Habitat Modification

Generally the most effective way to reduce deer damage is to select plants deer do not find palatable. Fortunately for the Oklahoma gardener, there are many such plants available. The Oklahoma State University fact sheet HLA-6427, *Ornamental and Garden Plants: Controlling Deer Damage* has an extensive list of plants and their relative attractiveness to deer. In areas where deer are a problem, consider replacing plants with those listed as less desirable. Examples of plants not generally damaged by deer include: blanket flower, lantana, salvia, zinnia, bee balm, butterfly weed, foxglove, gay-feather, goldenrod, lavender, penstemon, red-hot poker, rosemary, Russian sage, thyme, yarrow, holly, barberry, creeping mahonia, heavenly bamboo, yucca, sumac, cantaloupe, pepper, onion and tomato. If replacing plants is not an option, place susceptible plants together (to the extent possible) and use exclusion, repellents or scare tactics to protect that area of the garden.

Eastern Cottontail

The abundant cottontail is a common sight in many Oklahoma gardens. While generally a welcomed landscape guest, they can consume some of our tender annuals, perennials, vegetable crops and occasionally will girdle small trees. Rabbits stay in a small area, and a single yard may constitute an animal's entire home range. Even one rabbit can do substantial damage as the impacts are concentrated. In fact, rabbits will often consume an individual plant to the ground in a single visit. They are especially fond of tulip, hosta, rubeckia, pansy, peas, beans, rose, raspberry and blackberry. Rabbits are very prolific breeders during the summer and this is when most damage occurs. A rabbit's diet is similar to deer, yet damage is easy to differentiate as rabbit herbivory produces a very even, angled cut on stem tips and damage will be within 12 to 18 inches of the ground (Figure 11.4). Also, look for round droppings rather than the oval or clumped droppings of white-tailed deer. While rabbits do forage on lawns, they typically consume clovers and grass at rates that are not damaging. Thus, turf damage would be uncommon. Western Oklahoma gardeners may also have black-tailed jackrabbits in their landscape. Damage will be similar between the species.



Figure 11.4. Rabbit damage is characterized by very clean cuts on an angle as pictured here. This is opposed to a jagged cut from white-tailed deer.

Lethal Control

Rabbits are a regulated game species and may not be killed except as permitted by the Oklahoma Department of Wildlife (<http://wildlifedepartment.com/>) during regular hunting seasons. Hunting may be an option for rabbit even within cities, as air rifles and slingshots are legal to take rabbits and may be allowed in some city ordinances. However, as rabbits are easily excluded, lethal control is typically not recommended.

Repellents

Most of the same repellents advertised for deer are also advertised as effective at reducing rabbit damage to plants, with similar results. Contact repellents will again be more effective than area repellents. Thiram-based repellents are reported to be most effective. All repellents must be applied to a large portion of the plant to provide protection. Additionally, applications must be reapplied frequently. Expect to reapply every couple of weeks at minimum. Rain will cause more frequent reapplication. Areas with higher rabbit density and/or lower food resources will have reduced effectiveness from repellents. Also, the more preferred the target plant, the less effective the repellent will be. Consider using alternate or additional methods if high rabbit damage is encountered.

Frightening

Frightening provides little relief from rabbit damage. A dog may provide some damage alleviation.

Exclusion

Exclusion is the preferred method to minimize damage to landscape plants from rabbits. Fences of 2 feet will be sufficient to exclude rabbits. The fence should either be flush with the ground or buried a few inches into the soil. Mesh size 1 inch or smaller should be used. This is an effective strategy for small garden plots. For individual trees, the trunk may be wrapped with a wire mesh cylinder placed around the tree (Figure 11.3). Mesh of 1/4 inch should be used. This should be 2 feet for rabbits, although if deer are also a problem, consider a 4-foot or higher height. Ensure that the wire is not cutting into the bark of the tree.

Habitat Modification

Similar to deer, selection of unpalatable plants will largely eliminate rabbit damage. OCES fact sheet HLA-6427, *Ornamental and Garden Plants: Controlling Deer Damage* has an extensive list of plants and their relative attractiveness to deer. This list will greatly overlap with rabbits and can be used as a guide. If replacing plants is not an option, place susceptible plants together (to the extent possible) and use exclusion or repellents to protect that area of the garden. Additionally, rabbits require dense screening cover. They typically use tall grass, shrubs, brush piles or vines for cover. Removing cover can reduce rabbit use of an area. However, it also will change the aesthetics of the property and reduce use by many other species of wildlife the gardener may wish to attract.

Armadillo

The armadillo is one of the more interesting native mammals in Oklahoma. Unfortunately, they can cause substantial damage to lawns as they search for insects, grubs and earthworms in the soil. They also dig up shallow-rooted annuals in flower beds. Damage is generally most pronounced in the summer months. Irrigated lawns makes the soil easier to forage. Damage is easy to identify as it is noted by multiple shallow holes (Figure 11.5). Damage to rhizomatous grasses such as Bermuda is typically manageable as healthy grass can quickly fill in bare patches. Cool season grasses,



Figure 11.5. Armadillo damage is typically small shallow diggings scattered throughout the lawn or in mulch. Tree squirrel and skunk damage can look similar.

such as fescue, are more problematic because the bare patches will need to be reseeded in the fall. Additionally, the extra irrigation required by cool season grasses in the Oklahoma summer make them especially attractive to armadillo. The armadillo requires nearby cover that is generally woody thickets. Loose soils are much preferred for this burrowing animal. The armadillo appears to have expanded its range in recent years; however it often is reduced in numbers in northern Oklahoma following prolonged cold. This is the only other mammal other than humans known to become infected with leprosy. While the probability of infections is likely low, it is not recommended to handle armadillos with bare skin.

Lethal Control

Armadillos are not protected in Oklahoma and may be trapped or shot year-around. Shooting is an effective method where legal. However, as they are primarily nocturnal (particularly during the summer) this may not be a realistic control. Trapping is highly effective by using a large 10 x 12 x 32-inch live catch trap. The smaller live catch traps designed for skunks are too small. Traps with doors on either end are most effective. Use some type of barrier to funnel the armadillo into the trap. Existing barriers such as fences, walls, etc. work. If no existing barrier exists, use boards or temporary fence. The barrier only needs to be a few inches tall as armadillos rarely climb and will typically forage along any barrier they encounter (Figure 11.6). The trap does not need to be baited, although some homeowners have had success with rotten fruit or eggs. Place the trap either in the area of the landscape where damage is pronounced or where armadillos are entering the landscape (if known). As armadillos are often attracted to freshly irrigated lawns, consider placing traps in an area of the lawn immediately after irrigation. If damage is frequent, assume the animal has a burrow nearby in a wooded or riparian area. Once trapped, it is NOT legal to move the armadillo to another location. Transporting animals presents many problems such as disease transmission, displacement of existing wildlife and stress on the animal moved. Any trapped armadillo should be humanely killed with a shot to the base of the neck or in the head. Do not handle the armadillo to reduce potential of leprosy transmission.



Figure 11.6. Armadillos are generally easy to capture in a live-catch trap. While no bait is needed, the use of existing barriers and/or temporary barriers will greatly enhance capture. The idea is to create a funnel for the armadillo.

Repellents

There are no known effective repellents for armadillo.

Frightening

Frightening is not effective to reduce armadillo damage.

Exclusion

Exclusion is very effective to reduce armadillo damage to small garden beds. While armadillos can climb and burrow, they typically will not to access a small area. Fences taller than 12 inches should eliminate most armadillo invasion. For lawns, this is not typically practical.

Habitat Modification

Removal of protective brush may reduce armadillo damage. However, this will change the aesthetics of the property and reduce use by many other species of wildlife the gardener may wish to attract. Reducing irrigation can reduce damage.

Pocket Gopher

Pocket gophers are a widespread and abundant ground-dwelling rodent in Oklahoma. They are most abundant in loose soils, and are largely absent from some of the tight clay soils in the state. Thus, many gardeners will never deal with

gopher damage due to the inherent soil texture of their area. Gophers should not be confused with the similar mole (discussed below). Gopher burrows are generally not visible from the surface, although they do create large fan-shaped mounds of soil that is pushed to the surface (Figure 11.7). This is the characteristic sign of gopher damage. They consume plant material and can cause substantial damage to certain plants as they feed on roots. A gopher will rarely be seen aboveground, although they will consume plants aboveground at times. Damaged plants often exhibit rapid decline with no visible damage to plant aboveground. Hosta is a favorite, and when hostas seem to die overnight, gopher damage should be considered. Grass roots make up a large portion of the diet of gophers. Gardeners should be aware that a few gophers can create substantial burrowing. Thus, most landscapes will contain fewer gophers than assumed. OCES fact sheet NREM 9001, *Controlling Pocket Gophers* has additional information for control of this species.

Lethal Control

Gophers are not protected in Oklahoma and may be controlled year-round. There are two primary methods of lethal control: poisoning and trapping. Trapping is the preferred method of control for the gardener. This is because of the potential risk of non-target poisoning. If toxic control is used, zinc phosphide is one of the most common toxicants available for the home gardener and it is effective when applied according to label instructions. It also has lower risk to non-target animals. However, any toxicant can cause non-target mor-



Figure 11.7. Gophers do not typically leave visible tunnels. However, they push soil to the surface in fan-shaped mounds such as this.

tality if the dosage is high enough. Thus, ALWAYS place toxic baits directly into gopher tunnels. Also, check the baited area daily and properly dispose of any gophers that have come to the surface and died. To find the burrow, use an object such as a piece of rebar to probe around a mound area (around 12 inches from the mound). When the probe breaks through a tunnel, the soil should give way. Carefully punch a small hole into the top of the tunnel and place the toxic bait underground. If the hole is large, cover it so that no light enters the tunnel to alert the gopher. Trapping is very easy for gophers. There are several types of traps available and can be found at most lawn and garden stores. Use the same method as above to locate the burrow. Once found, carefully dig a hole into the top of the burrow just large enough to place the trap. If using a trap that only will catch a gopher from one direction, place two traps back-to-back, so the gopher will be caught regardless of the direction it is traveling (Figure 11.8). Attempt to not knock soil into the burrow. Cover the hole with soil removed if it is not too loose, otherwise place a board, burlap, or other object over the hole to keep out light so the approaching gopher will not be alerted to the disturbance. Mark the trap and check in two days. If a gopher is not caught, move the traps to a new location.

Repellents

There are no known effective repellents for gophers.



Figure 11.8. Some gopher traps only work in one direction. For this type of design put two traps back to back so that the gopher can be caught regardless of the direction traveled.

Frightening

Frightening is not proven to be effective at reducing damage from gophers.

Exclusion

Exclusion can be effective for small high-value areas such as small vegetable gardens and ornamental plantings. Consider placing high-value or frequently damaged plants (such as Hosta) in the same bed and protect with metal fence (1/4-inch mesh) placed at least 18 inches underground. Alternatively, use a 24-inch fence bent at a 90 degree angle (facing outward from the protected area), so the fence will be 12 inches vertical with an additional 12 inches of horizontal protection once bent to prevent gophers from digging under the barrier. Underground wiring or irrigation tubing is sometimes damaged by gophers. Enclosing the cable or tubing in a 3-inch tube will protect the contents as gopher cannot open their jaws wide enough to damage the tube.

Habitat Modification

None practical for the home gardener.

Mole

Moles are small mammals that spend the vast majority of their life underground (Figure 11.9). They are common in Oklahoma, particularly in loose rich soils under a canopy of trees. While often confused with pocket gophers, their similarities end with an underground lifestyle. Moles are



Figure 11.9. Moles are rarely seen above ground. Occasionally they will be dug up by dogs and cats in the landscape.



Figure 11.10. Mole tunnels are generally visible on the surface of the lawn and appear as slightly raised areas.

insectivores and feed voraciously on earthworms, grubs and other insects. This diet, along with the aeration of soil from their many tunnels makes them a very beneficial garden animal. However the tunnels can be unsightly, make it difficult to walk and sometimes expose shallowly rooted plants to air pockets in the soil, causing death (Figure 11.10). While sometimes a nuisance, control is generally not warranted for this animal.

Lethal Control

Moles are not protected in Oklahoma and may be controlled year-round. Trapping is the preferred method of control for the gardener as toxicants are not as effective for controlling moles. Tunnels are generally highly visible when moles are present. Traps placed within the burrows (similar to gopher traps) may be used. To set this type of trap, carefully dig a hole into the top of the burrow just large enough to place the trap. If using a trap that only will catch a mole from one direction, place two traps back-to-back, so the mole will be caught regardless of the direction it is traveling (Figure 11.8). Do not knock soil into the burrow. Cover the hole with soil if it is not too loose, otherwise place a board, burlap or other opaque object over the hole to keep out light. Mark the trap and check in two days. If a mole is not caught, move the trap to a new location. However, harpoon style traps are easier to use for moles. These are placed directly over an active tunnel. To set, remove the soil from a small section of a tunnel so the underground tunnel location can

be precisely determined. Then replace the soil, packing it firmly. Place the harpoon trap directly over the tunnel. Set the trigger so it barely touches the soil. When the mole comes through the tunnel, it will push the soil back up and trigger the trap. Only disturb the area of the tunnel where a trap is set. Alternatively, carefully observe the lawn early or late in the day, sometimes a mole may be seen moving through the soil. Carefully approach the area and then quickly dig up the mole.

Repellents

There are no known effective repellents for moles.

Frightening

Frightening is not proven to be effective at reducing damage from moles.

Exclusion

Exclusion is impractical for lawns. Small flower beds can be protected by installing wire fence underground. Use 24-inch fence (1/4-inch mesh) bent at a 90 degree angle (facing outward from the protected area), such that the fence will be 12 inches vertical with an additional 12 inches of horizontal protection once bent.

Habitat Modification

Decreasing irrigation can decrease food resources for the mole, yet will impact plant production. Soil insecticides are not recommended because they must be applied over large areas and moles are easy to trap, thus eliminating soil insects should not be necessary.

Woodpecker

Oklahoma is home to eleven species of woodpecker. However the vast majority of complaints come from a single species known as the yellow-bellied sapsucker, which causes damage to certain species of trees during the winter. All woodpeckers can occasionally cause structure damage or an annoyance from drumming to attract mates. All woodpeckers also feed on insects on and in trees. Typically, trees that are already damaged, dying or diseased are foraged on by woodpeckers as these trees harbor abundant insects. Thus, the woodpecker is seldom responsible for the death of the tree. Further, most woodpeckers excavate



Figure 11.11. Typical damage from a yellow-bellied sapsucker consists of numerous shallow holes about the size of a pencil eraser. These are sometimes in very orderly rows and columns and are usually found on maples, pines and fruit trees.

nest cavities in dead and dying trees. However, the yellow-bellied sapsucker causes damage to healthy living trees and is a widespread winter resident in Oklahoma. This woodpecker species typically shows up in late October or November and departs in late February or March. It creates numerous small round depressions along the bark of trees (Figure 11.11). This is primarily confined to the trunk, but may be evident on large limbs as well. These shallow holes are made to allow sap to rise. Sapsuckers consume the sap and insects that become trapped in it. Sapsuckers typically damage tree species that readily produce sap. Maples, pines and various fruit trees are commonly damaged. Any time the cambium is exposed, trees are susceptible to disease and insects. However, native trees are generally able to withstand this damage with no adverse effects. This is evident on old maple trees that have thousands of small cavities drilled in them. The same sap that makes them attractive to sapsuckers, usually serves as protection against disease. Nonnative trees are more susceptible to local insect and disease pests and will be at a higher risk. Occasionally, sapsuckers create so many cavities that they girdle the tree.

Lethal Control

All woodpeckers are protected by the Federal Migratory Bird Treaty Act of 1918 and may not be legally harmed.

Repellents

In general repellents are not effective for woodpeckers. Tactile repellents that provide a sticky layer on the surface of wood may reduce woodpecker use. However, some of these materials can discolor wood surfaces (for structures) and can become very messy during hot weather.

Frightening

Frightening is generally not effective for alleviating woodpecker damage. Limited success has been reported for some motion-type devices, but the gardener should not have high expectations.

Exclusion

Exclusion is generally the most effective method of damage management for sapsuckers. Metal hardware cloth (1/4-inch) can be wrapped around tree trunks that are frequently damaged. Metal flashing can also be used. If an orchard with many trees is being impacted, evaluate the number of trees damaged. Often, only one or two trees will have significant damage. If this is the case, these trees could be used as “sacrifice trees” rather than protecting them only to have adjacent trees subsequently damaged. If structures are being damaged, use netting if the area is small (e.g. wooden eaves). If the entire structure is wood, exclusion will not be practical. In this case a combination of other methods such as frightening, suet and nest boxes combined with quickly covering any damage with aluminum flashing should be used.

Habitat Modification

As sapsuckers target certain types of trees, the judicious selection of trees for the landscape can greatly reduce damage. In general, oaks and elms are not damaged by sapsuckers. Some limited success is reported by using suet as a food diversion. Nest boxes can be placed to provide an alternate nest site when concern of cavity construction is an issue. However, some species of woodpecker will not readily use artificial nest boxes.

Canada Geese

Canada geese cause considerable damage to agriculture crops such as winter wheat. Geese are grazing animals that feed primarily on grass. While they can uproot newly planted grass, they typically clip established lawns and cause limited damage.

However, they can be aggressive and their fecal material creates a mess. For the home gardener, damage is mostly in the form of a nuisance. There are two distinct classifications of Canada geese. There are both resident geese (those that do not migrate) and migratory geese. While geese are protected by the Federal Migratory Bird Treaty Act of 1918, special provisions exist for controlling resident geese (those present in the summer) which are discussed below.

Lethal Control

Migratory Canada geese may only be hunted during the authorized hunting season as determined by the U.S. Fish and Wildlife Service. This is seldom an option for the home gardener. Resident Canada geese can be killed under certain circumstances by a licensed Nuisance Wildlife Control Operator (NWCOs). The Oklahoma Department of Wildlife Conservation has a list of licensed NWCOs available for landowners (http://wildlifedepartment.com/laws_regs/nco.htm). Note these individuals charge a fee for damage management.

Repellents

There are no known available repellents effective for Canada geese.

Frightening

Frightening is not generally effective unless combined with other methods. As with all scare tactics, unpredictability will help as animals quickly become accustomed to sounds, movements and objects. The only highly recommended method of frightening for Canada geese is the use of dogs trained to chase geese. This can be highly effective even on large areas such as golf courses.

Exclusion

Exclusion is generally not practical. However, steel wire or heavy monofilament can be used to create grids at the water surface (5-foot centers) to discourage geese from landing on small water bodies. This is generally an expensive method and may be aesthetically displeasing. Geese can also be excluded during the summer with standard fences, as adults are reluctant to leave goslings behind. However, once the young can fly, this will no longer be effective.

Habitat Modification

Not practical for gardeners.

Tree Squirrels

There are three species of tree squirrel found in Oklahoma. The fox squirrel is found across the state while the Eastern gray squirrel is found in the eastern portions of the state. Southern flying squirrels are also present, but are generally not common, and except for occasionally entering attics, do not cause significant damage. Both the fox and gray squirrel feed on a variety of food. In the garden, they cause damage to nut-bearing trees, various fruits, corn and consume bird seed. They sometimes dig in lawns to bury food and can enter openings in attics. They also evict birds from nest boxes at times.

Lethal Control

While both the fox and gray squirrel are legal game species, seasons are very liberal and they may be killed most of the year (<http://wildlifedepartment.com>). Where legal, shooting is effective to control squirrels under low population densities. However, with high densities, animals will be quickly replaced.

Repellents

Various repellents such as moth balls and capsaicin can reduce damage in some instances, but will generally not be effective alone and must be reapplied often.

Frightening

Not generally effective for reducing squirrel damage.

Exclusion

If squirrels are entering attics or other structures, cover the entrance(s) with wire mesh, aluminum flashing and other materials as appropriate. Be cautious about trapping squirrels inside, as they can do significant damage attempting to escape and will smell once dead. If animals are suspected to be inside the structure, place a live catch trap (baited with peanut butter, nuts or fruit) inside the enclosed space, or create a temporary one-way door over the opening. Use a metal (preferable) or plastic collar to prevent squirrels from climbing trees or bird feeders (Figure 11.12). The collar should be 2 feet wide and 6 feet off the ground to fully exclude squirrels. If placing on a tree, ensure



Figure 11.12. Cones placed below bird feeders or trees help reduce squirrel damage. Metal cones are preferred over plastic as plastic can be damaged by the squirrel as shown in this photo.



Figure 11.13. This squirrel guard prevents the nesting birds from being destroyed. The hole should be appropriate for the target bird but small enough to limit squirrel entrance (more than 2 inches). If using metal flashing, be sure to file edges to ensure birds entering will not be injured.

there is space between the collar and tree to prevent damage to the tree. Woven wire (1-inch mesh) fence topped with a single strand electrical wire (within 1 inch of top of fence) can be installed to protect small garden plots. If sweet corn is being damaged, use a piece of reinforced filament tape wrapped several times around the end of each ear of corn to inhibit squirrels from opening the husk. This should be done prior to the corn becoming ripe. If squirrels are raiding bird houses, a metal or hard plastic collar can be placed around the opening that will restrict their entry by preventing them from chewing the entrance hole larger (Figure 11.13).

Habitat Modification

Tree limbs can be trimmed to prevent squirrels from accessing structures, gardens, bird feeders, other trees, etc. Limbs should be trimmed 8 feet from the object protected as squirrels can jump several feet.

Northern Raccoon

The Northern raccoon is a widespread mammal found throughout Oklahoma. They consume a wide variety of foods (omnivorous), are intelligent and have good dexterity. These traits sometimes lead to conflicts with homeowners and gardeners. While they prefer areas near forests and water, they can be found far from either. They are primarily nocturnal, thus often not seen. They cause damage by raiding garbage cans, bird feeders, and bird houses; entering attics; consuming vegetable crops (especially corn); and occasionally pulling up fresh sod. If raccoons are present in an attic, they generally make considerable noise by running, scratching and snarling. Other species of wildlife that sometimes enter attics are generally more subtle.

Lethal Control

Raccoons are a regulated furbearer in Oklahoma. The Oklahoma Department of Wildlife Conservation sets seasons and legal methods of harvest (<http://wildlifedepartment.com>). Raccoons can be killed if they are harming livestock or poultry at any time. For nuisance issues which require trapping outside of an established hunting season, contact a NWCO in your area ([\[ment.com/laws_regs/nco.htm\]\(http://wildlifedepartment.com/laws_regs/nco.htm\)\). Raccoons can be trapped using live catch traps \(10 x 12 x 32 inches\) baited with sardines, chicken, or cat food. However, the use of smaller mesh \(1/2-inch\) wired to the cage may be needed to prevent raccoons from pulling out the bait through the trap walls. In most cases, lethal control will not be necessary for raccoons. An exception may be in the rare case when raccoons enter attics or crawl spaces of structures.](http://wildlifedepart-</p></div><div data-bbox=)

Repellents

No known repellents are effective for raccoons.

Frightening

While frightening may temporarily lessen damage from raccoons, it is not generally effective and not recommended.

Exclusion

Exclusion is the most effective way to reduce most raccoon damage. For garbage cans, tightly restrain lids with bungee cords. Consider using metal containers for any food item to discourage raccoons from chewing into the container. For raccoons entering structures, seal any holes where entry is possible immediately upon discovering the entry. Trap any raccoons that may be present after the entry is sealed or by blocking the entry with a trap. Ensure chimneys are covered with wire mesh and/or capped to prevent entry. For small corn crops, use filament reinforced tape wrapped several times around the end of each ripening ear of corn. For larger areas, use an electric fence with two hot wires, with the first wire at about 6 inches above the ground. Poultry should be well fenced with all doors and windows secured at night. A single electric wire along the top of the poultry fence will greatly reduce raccoon damage. If raccoons are raiding bird nest boxes, install a predator shield (cone) to limit access (Figure 11.12). Metal, rather than plastic should be used if raccoons are a problem.

Habitat Modification

There are few instances where habitat modification is practical. If fresh sod is being damaged by raccoons, consider pinning down the corners with pins or stakes until the grass has firmly established roots. Overhanging limbs can be trimmed to prevent access to the roof of a structure or to bird houses.

Striped Skunk

Oklahoma has two species of skunk. The spotted skunk is very uncommon and is a protected species. It will seldom, if ever, cause problems for the Oklahoma gardener. The striped skunk is a common mammal found statewide. They are most common in open areas near forests and streams, but are quite adaptable. Skunks eat a wide variety of foods, but insects are eaten during the summer months. Skunks occasionally raid poultry eggs, eat low hanging vegetables and get into garbage. However, most complaints from skunks involve either damage to turf because they seek soil insects or when skunks enter the crawl spaces of homes. Skunk damage in lawns can look similar to tree squirrels and armadillo. Tracks or visual sighting are the best ways to differentiate between species causing turf damage. Note that most turf damage in Oklahoma gardens will be from armadillo and not from skunk.

Lethal Control

Striped skunks are not protected in Oklahoma and may be killed at any time. They can be easily trapped using live catch traps (7 x 7 x 24 inches). The trap should be baited with cat food or sardines. While skunks are not eager to spray and are very docile animals, it is still advisable to cover the trap with canvas or some other covering to reduce the chance of spray. As it is illegal to move wildlife, humanely kill any trapped skunks. Approach the trap calmly, pull back the cover and shoot the animal in the head. Many skunks will spray when shot, but shooting the brain will reduce the chance and will kill the animal instantly. Shooting the animal from a distance (to avoid the possibility of getting sprayed) will almost certainly cause the animal to spray the trap. If the skunk does spray, use a mixture of one quart hydrogen peroxide, ¼ cup baking soda, and two teaspoons liquid dish soap to clean the trap. Note: do not seal this mixture in a container as the hydrogen peroxide releases gas which can cause a closed container to explode. Alternatively, call a NWCO to trap for you (http://wildlifedepartment.com/laws_regs/nco.htm).

Repellents

Not generally effective. Mothballs may work for enclosed spaces, but should be used cautiously where people reside.

Frightening

Lights and loud noises may provide some relief.

Exclusion

Exclusion is the most effective way to reduce most skunk damage. For garbage cans, tightly restrain lids with bungee cords. Consider using metal containers for any food items. For skunks entering structures, seal any holes where entry is possible immediately upon discovery. Trap any skunks that may be present at the entry point using sardines or cat food as bait. Poultry should be well fenced with all doors and windows secured at night. Fences should be buried about 12 inches if skunks are digging under them.

Habitat Modification

Keep brush, debris and garbage picked up to reduce the attractiveness to skunks.

Additional References

The Internet Center for Wildlife Damage Management contains information on many wildlife species (<http://icwdm.org>).

The following Oklahoma State University fact sheets can be found at osufacts.okstate.edu

Ornamental and Garden Plants: Controlling Deer Damage, HLA-6427

Controlling Pocket Gophers, NREM-9001

The USDA Animal and Plant Health Inspection Service is a good resource for wildlife damage impacting agriculture or human health and safety (http://www.aphis.usda.gov/wildlife_damage).

The Oklahoma Department of Wildlife Conservation sets regulations for resident wildlife species and also manages the Nuisance Wildlife Control Operator Program (<http://wildlifedepartment.com>)