

The Oklahoma Cooperative Extension Service WE ARE OKLAHOMA

The Cooperative Extension Service is the largest, most successful informal educational organization in the world. It is a nationwide system funded and guided by a partnership of federal, state, and local governments that delivers information to help people help themselves through the land-grant university system.

Extension carries out programs in the broad categories of agriculture, natural resources and environment; family and consumer sciences; 4-H and other youth; and community resource development. Extension staff members live and work among the people they serve to help stimulate and educate Americans to plan ahead and cope with their problems.

Some characteristics of the Cooperative Extension system are:

- The federal, state, and local governments cooperatively share in its financial support and program direction.
- It is administered by the land-grant university as designated by the state legislature through an Extension director.
- Extension programs are nonpolitical, objective, and research-based information.
- It provides practical, problem-oriented education

for people of all ages. It is designated to take the knowledge of the university to those persons who do not or cannot participate in the formal classroom instruction of the university.

- It utilizes research from university, government, and other sources to help people make their own decisions.
- More than a million volunteers help multiply the impact of the Extension professional staff.
- It dispenses no funds to the public.
- It is not a regulatory agency, but it does inform people of regulations and of their options in meeting them.
- Local programs are developed and carried out in full recognition of national problems and goals.
- The Extension staff educates people through personal contacts, meetings, demonstrations, and the mass media.
- Extension has the built-in flexibility to adjust its programs and subject matter to meet new needs. Activities shift from year to year as citizen groups and Extension workers close to the problems advise changes.



Construction of Table Gardens

October 2018

Casey Hentges

Assistant Extension Specialist

Qing Lana Luo

Assistant Professor, Extension Landscape Architecture Specialist

Laura Payne

Extension Associate

Oklahoma Cooperative Extension Fact Sheets are also available on our website at: facts.okstate.edu

Everyone should have the opportunity to garden, however, traditional gardening at ground level can be physically demanding on your knees and back. Often, it requires bending, stooping and kneeling, which can be challenging for some people. Bringing the planting bed up to waist height can provide a more comfortable opportunity to garden. It also provides head-on access for people who sit in wheelchairs and allows their knees to go under the raised planter sitting straight.

Table gardens have all the same benefits of other raised beds, such as improved planting media, good drainage and reduced weed encroachment. Table gardens are ideal for temporary gardening locations, poor soils, outdoor classrooms, paved areas and small patios.

Building a Table Garden

Materials:

- 55-gallon plastic barrel (food grade)
- 140 inches 4x4-inch posts
- 322 inches 2x4-inch boards
- 216 inches of decking board
- Several 1 5/8-inch screws
- Several 2 1/2-inch screws
- Washers
- Sand Paper
- All-weather wood sealer

Tools:

- Reciprocating saw
- Circular saw or miter chop saw
- Tape measure
- Triangle
- Clamps
- Pencil
- Drill with screw bit



Dimensions 54 inches x 38 inches x 36 3/4 inches: length x width x height.

Oklahoma State University, as an equal opportunity employer, complies with all applicable federal and state laws regarding non-discrimination and affirmative action. Oklahoma State University is committed to a policy of equal opportunity for all individuals and does not discriminate based on race, religion, age, sex, color, national origin, marital status, sexual orientation, gender identity/expression, disability, or veteran status with regard to employment, educational programs and activities, and/or admissions. For more information, visit <https://eeo.okstate.edu>.

Issued in furtherance of Cooperative Extension work, acts of May 8 and June 30, 1914, in cooperation with the U.S. Department of Agriculture, Director of Oklahoma Cooperative Extension Service, Oklahoma State University, Stillwater, Oklahoma. This publication is printed and issued by Oklahoma State University as authorized by the Vice President for Agricultural Programs and has been prepared and distributed at a cost of 40 cents per copy. 1018 GH.

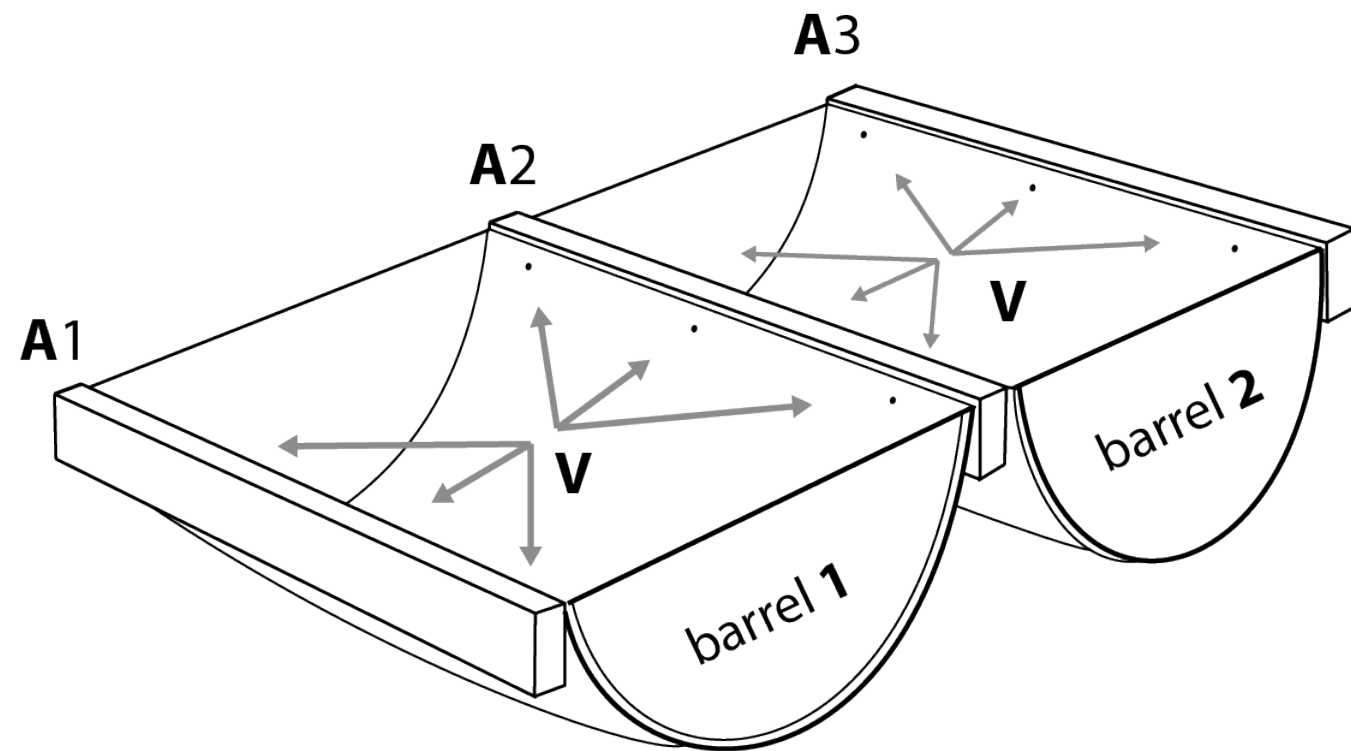

Figure 1.

Constructing Table Top

1. Cut barrel in half – lengthwise, giving you 2 half barrels.
2. Cut 2x4-inch board to length of barrel. You will need three of these lengths (A1, A2 and A3 on Figure 1).
3. Using 1 5/8-inch screws, attach a 2x4-inch board (A1 & A2) to the outside of barrel 1, along the long cut edges. Use clamps to hold 2x4-inch board in place. Insert screws at point V (See Fig 1) from inside the barrel into wood and use washers to reinforce hole in barrel. (See Photo 1)
4. Attach the second half barrel (barrel 2) to board A2. Again, use clamps to hold barrel in place and use washers and insert 1 5/8-inch screws from inside the barrel 2 into board A2 at Point V in Figure 1.
5. Attach the third 2x4-inch board (A3) to the other side of the second half barrel (2), again using clamps, washers and insert 1 5/8-inch screws from inside the barrel into wood at Point V in Figure 1.
6. Turn barrels upside down and set aside.



Photo 1.

Constructing Table Legs

7. Cut 4x4-inch post to 36-inch length. You will need four of these posts (B on Figure 2). Thirty-six inches will be the height of the table; different lengths can be used to make a shorter or taller table, based on preference.
8. Using the reciprocating saw, notch out one end of each 4x4-inch post so that A1 and A3 will be supported by the 4x4-inch posts. See inset in Figure 2.
*Note – 2x4-inch boards are not true measurements; 2x4-inch boards are typically 1 1/2 x 3 1/2 inches.
9. Using 2 1/2" screws, attach the notched end of the 4x4 post to each end of 2x4-inch boards attached to barrels (A1 & A3) at Point W in Figure 2. These will be the corner legs of the table. Take care that the edges of the 4x4-inch post and the 2x4-inch boards align at the ends; another board will be placed flush against these edges (C1 top & C2 top).
10. Measure the total width of the attached barrels with the attached wood to get accurate measurement for C1 & C2 top and bottom boards in Figure 2. Measure from the outside edge of one 4x4-inch board to the outside edge of the opposite 4x4-inch board, across the two barrel halves. Measure both sides, as the two sides (C1 & C2) may be different lengths.
11. Cut two 2x4-inch boards for the length of each table side (C1 top, C1 bottom, C2 top and C2 bottom).



Photo 2.

12. Using 2 1/2-inch screws at Point X in Figure 2 attach one of these cut 2x4-inch boards to each side of the table (C1 top & C2 top).
13. Using 2 1/2-inch screws, attach remaining two 2x4-inch boards (C1 bottom & C2 bottom) to the inside of 4x4-inch legs (B) at points Y in Figure 2. The boards should rest firmly upon the barrels, in order to help support the weight of the barrels when the table is turned right side up. See Photo 2.

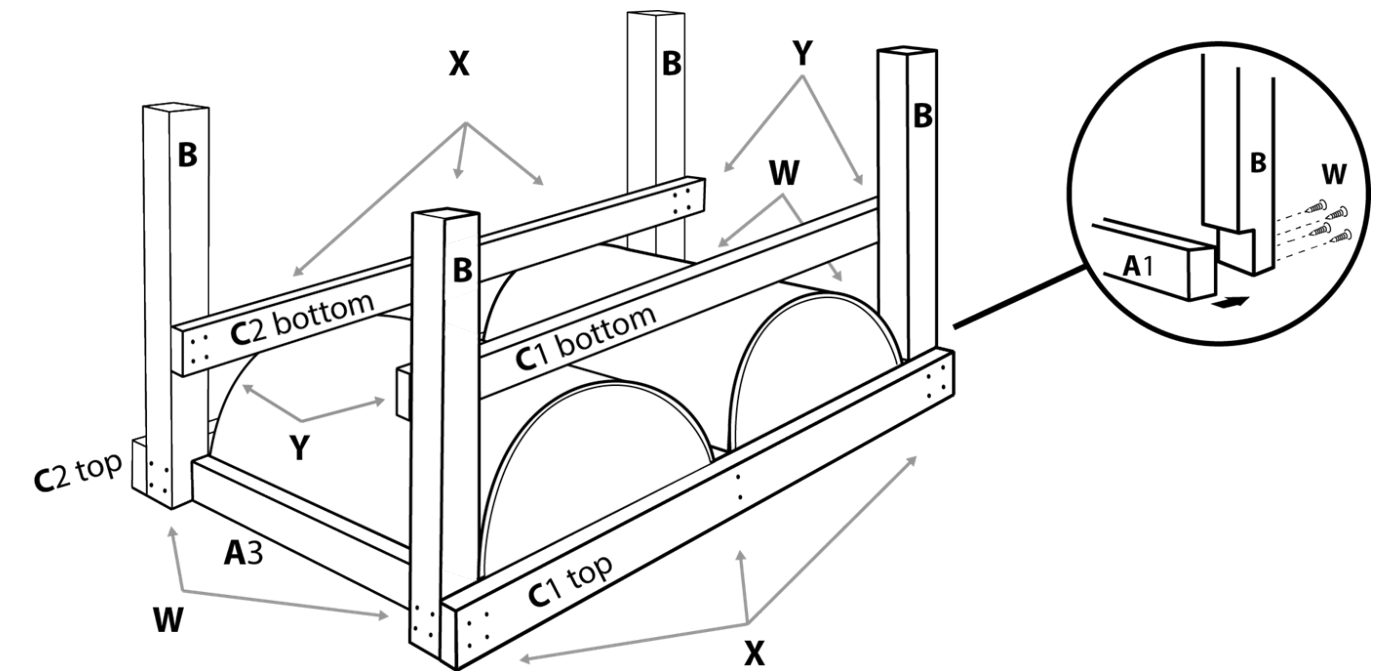

Figure 2.

Finishing Table Garden

14. Flip the entire table over so that it is right side up.
15. Insert 1 5/8-inch screws with washers from inside the barrel to attach each half barrel to C1 & C2 tops at Point Z.
16. Drill holes in bottom of barrels for drainage. The number and size of holes for drainage will vary, depending on the soil media and plant selection. It is easier to increase drainage later by drilling more holes in the bottom of the barrel after planting than it is to reduce drainage.
17. Use triangle to make mitered corners, and 1 5/8-inch screws to frame the top of the table with decking boards. See Figure 3 and Photo 3.
18. Sand smooth.
19. Paint or weather seal wood.
20. After the paint has dried, fill the barrels with potting soil.
21. Plant!



Photo 3.

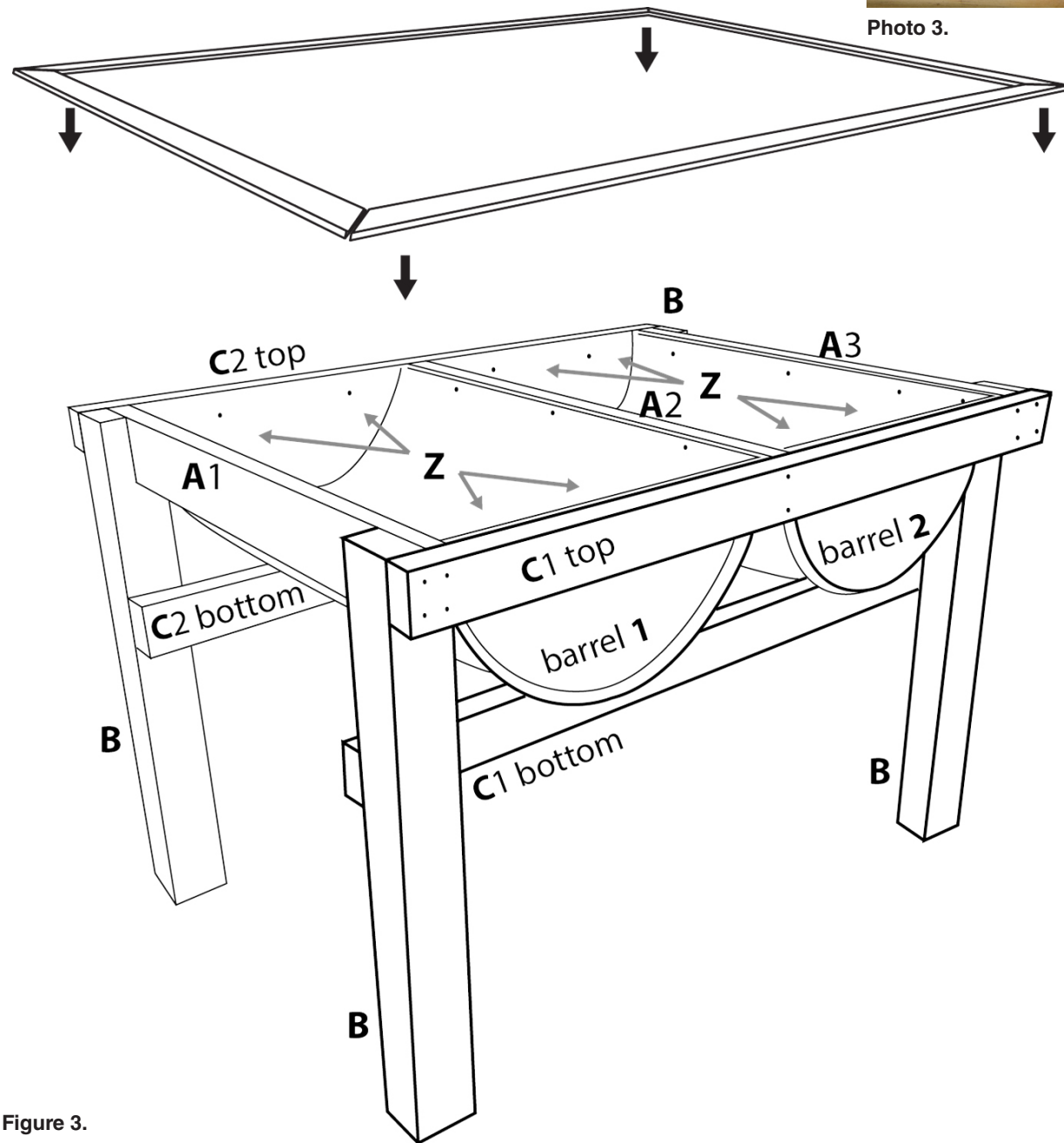

Figure 3.

Planting Your Table Garden

Table gardens are ideal for most annual vegetables and herb plantings. Due to the elevation, garden tables are not recommended for growing taller vegetables, such as corn and taller okra varieties, as the crop will be out of reach and the plant will be exposed to more wind. In addition, the growth habit of heavy vines, such as watermelon and pumpkins are not ideal for table gardens.

A table garden is similar to a container garden and may dry out faster, requiring more watering than if you were to plant the same plants in the ground. The benefit to this is they will also drain faster during heavy spring rains.

Other OSU Extension Gardening Publications:

HLA-6004: Oklahoma Garden Planning Guide
 Oklahoma Gardening Video <https://youtu.be/ZDe3Yxc0nZc>

Table 1. Ideal table gardening plants.

Warm Season	Cool Season	Herbs
Beans	Beets	Basil
Eggplants	Carrots	Borage
Peppers	Chard	Catnip
Squash	Garlic	Chives (onion & garlic)
Tomatoes	Kale	Cilantro
Zucchini	Lettuce	Dill
	Onions	Fennel
	Peas	Lavender
	Radish	Lemon Balm
	Spinach	Lemon Verbena
	Turnips	Marjoram
		Mint
		Oregano
		Parsley
		Rosemary
		Sage
		Savory
		Scented Geraniums
		Thyme

